

Specification

Name:	Tri Auto ZX2	Handpiece	Free Running Operation
Model:	TR-ZX2	Speed:	100 ±20 – 1000 ±100 rpm
Manufacturer:	J. MORITA MFG. CORP.	Torque:	4 Ncm or more
Functions:	Root Canal Measurement OGP (Optimum Glide Path) OTR (Optimum Torque Reverse) OAS (Optimum Apical Stop) Auto Start / Stop Auto Torque Reverse Auto Apical Reverse / Stop Auto Apical Slow Down Auto Apical Torque Down Auto Torque Slow Down	Battery:	Lithium-ion battery (DC 3.7 V)
Accessories:	Tester, Spray Nozzle	Weight:	Approx. 140 g (including battery and contra angle)
Options:	LS Spray, Handpiece Holder, External File Electrode (with cap)	Battery Charger	Rated Input Voltage: DC 5 V
		Rated Input Current:	2.4 A
		Weight:	Approx. 280 g (AC adapter not included)
		AC Adapter	Rated Input Voltage: AC100 - 240 V
		Rated Input Frequency:	47 - 63 Hz
		Rated Input Current:	0.4 A



Development and Manufacturing
J. MORITA MFG. CORP.
 680 Higashihama Minami-cho, Fushimi-ku,
 Kyoto 612-8533, Japan
 T +81. (0)75. 611 2141, F +81. (0)75. 622 4595

Morita Global Website
www.morita.com

Distribution
J. MORITA CORP.
 3-33-18 Tarumi-cho, Suita-shi, Osaka 564-8650, Japan
 T +81. (0)6. 6380 1521, F +81. (0)6. 6380 0585

J. MORITA USA, INC.
 9 Mason, Irvine CA 92618, USA
 T +1. 949. 581 9600, F +1. 949. 581 8811

J. MORITA EUROPE GMBH
 Justus-von-Liebig-Strasse 27a, 63128 Dietzenbach, Germany
 T +49. (0)6074. 836 0, F +49. (0)6074. 836 299

MORITA DENTAL ASIA PTE. LTD.
 3 Science Park Drive,
 #01-05 The Franklin Singapore Science Park1, Singapore 118223
 T +65. 6779. 4795, F +65. 6777. 2279

J. MORITA CORP. AUSTRALIA & NEW ZEALAND
 Suite 2.05, 247 Coward Street, Mascot NSW 2020, Australia
 T +61. (0)2. 9667 3555, F +61. (0)2. 9667 3577

J. MORITA CORP. MIDDLE EAST
 4 Tag Al Roasaa, Apartment 902, Saba Pacha 21311 Alexandria, Egypt
 T +20. (0)3. 58 222 94, F +20. (0)3. 58 222 96

J. MORITA CORP. INDIA
 Filix Office No.908, L.B.S. Marg, Opp. Asian Paints, Bhandup (West), Mumbai 400078, India
 T +91-22-2595-3482

J. MORITA MFG. CORP. INDONESIA
 28F, DBS Bank Tower, Jl. Prof. Dr. Satrio Kav. 3-5, Jakarta 12940, Indonesia
 T +62-21-2988-8332, F + 62-21-2988-8201

SIAMDENT CO., LTD.
 71/10 Mu 5, Thakham, Bangpakong, Chachuengsao 24130, Thailand
 T +66. 38. 573042, F +66. 38. 573043
www.siamdent.com

Catalog Design: f/p design, Germany

Subject to technical changes and errors.
 1703 TriAuto ZX2 Br En
 JME EN BS 0218 *1.

- Diagnostic and Imaging Equipment ■
- Treatment Units ■
- Handpieces and Instruments ■
- Endodontic System ■
- Laser Equipment ■
- Laboratory Devices ■
- Educational and Training Systems ■
- Auxiliaries ■

Tri Auto ZX2

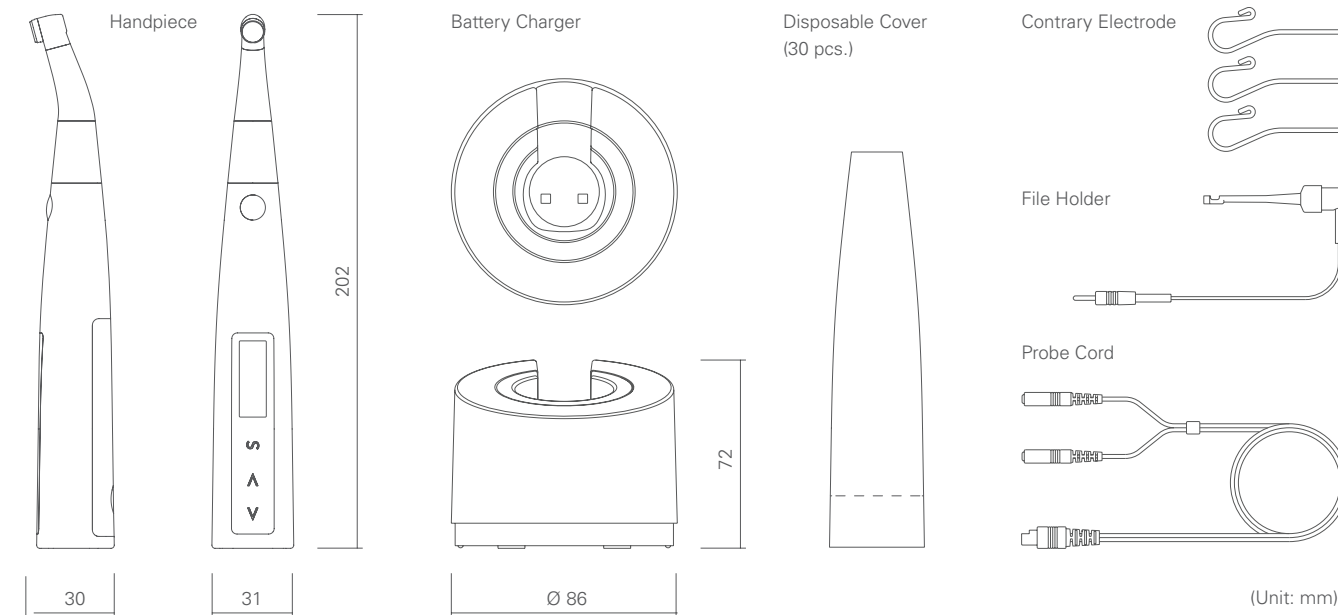

Apical Patency by Rotary Instrumentation

Now Possible with Rotary Files as Small as #10

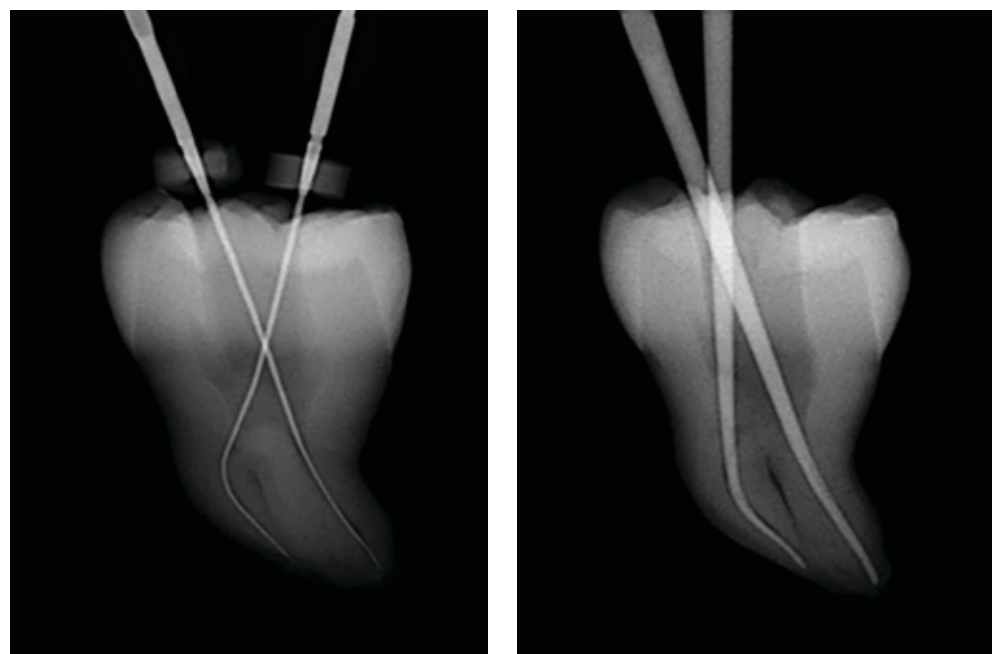

A Motor for Apical Patency, Glide Path, and Shaping

Tri Auto ZX2 is a compact, cordless motor with a built-in apex locator. It can be used for obtaining apical patency and creating a glide path using rotary instrumentation. Rotary files even as Small as #10 may be used for these procedures. Responsive, the handpiece allows subtle and delicate manipulation of the file, corresponding to the movements of an experienced dentist's hand. Tri Auto ZX2 also offers a safe and efficient method for canal shaping.



Clinical images are provided by Dr. Yoshi Terauchi / Dr. Toshihiro Ushikubo / Dr. Tai Gega

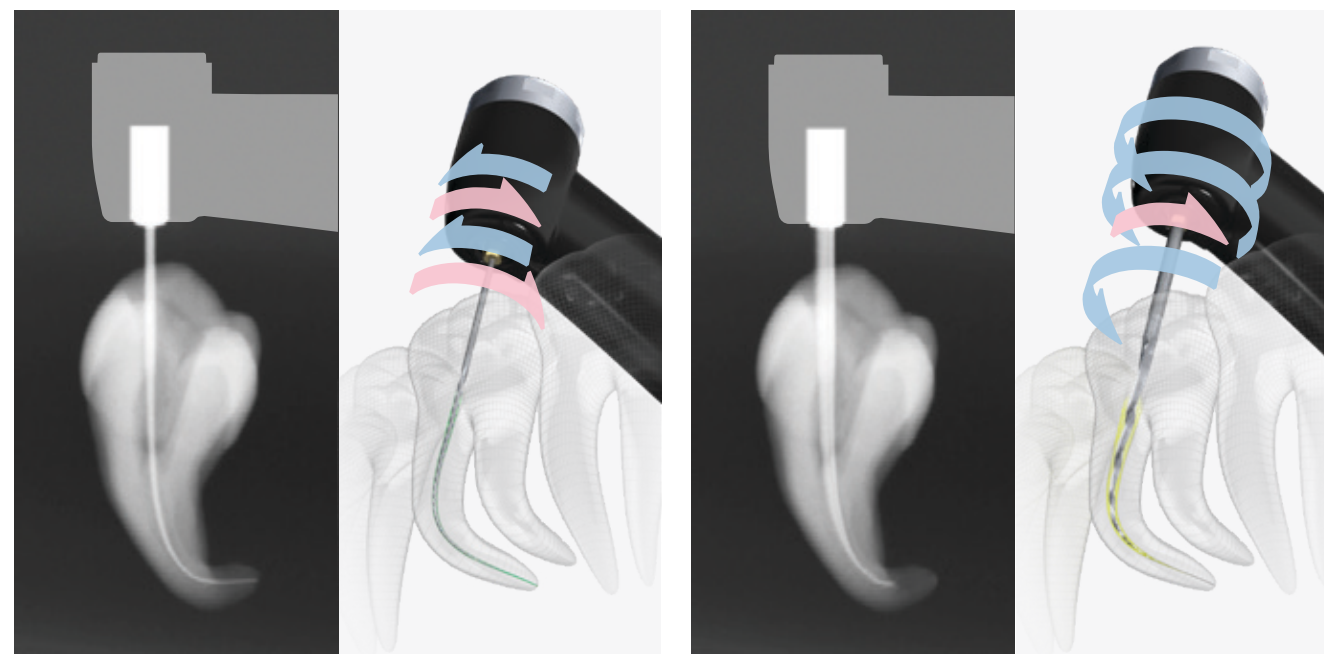

Apical Patency and Glide Path Using a Motor

OGP Function (Optimum Glide Path)

Using #20 or smaller files, the motor can be used to achieve apical patency and create a glide path. It reproduces the subtle and delicate finger movements of an experienced dentist. Even curved or constricted canals can be treated faster and more safely. Both NiTi files sized #20 or smaller, or stainless steel files sized #15 or smaller may be used.

Safer and Efficient Canal Shaping

OTR Function (Optimum Torque Reverse)

Depending on the load on the file, the motor alternates between forward and reverse rotation with great sensitivity to prevent jamming and file breakage. It is also superior in its ability to follow the shape of even curved canals to reduce ledges and over instrumentation. Tri Auto ZX2 is compatible with standard NiTi files - no need to purchase specialty files.

Canal Shaping Procedure

- Step 1**
Canal shaping (Upper part)
- Step 2 / OGP**
Patency
- Step 3 / OGP**
Glide path
- Step 4 / OTR**
Canal shaping

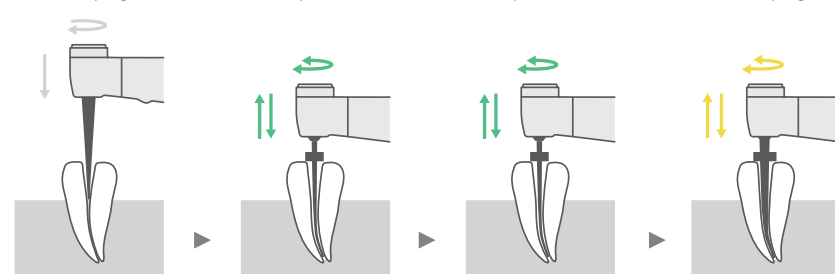

File tip position is monitored in real time.



File Tip Position Monitored in Real Time

File location and canal length are monitored in real time. Even if the working length is altered by shaping, the display accurately shows the file position with respect to the working length.

Apical Control

Observe the File Tip Position with the Apex Locator Function

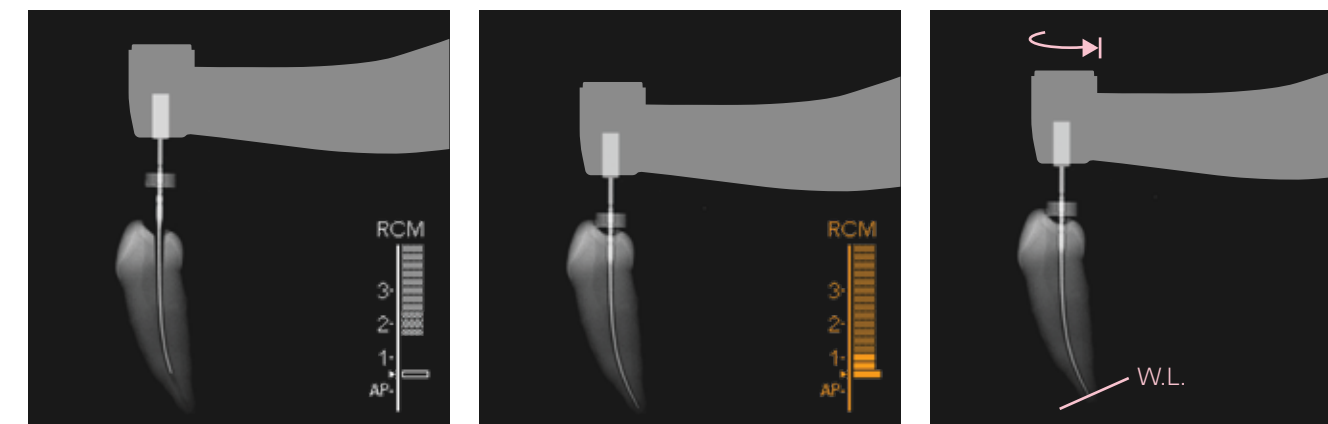

Automatic Stop Safety Function

The Tri Auto ZX2 motor is linked with the canal measurement function. This feature makes endodontic treatment safer and more efficient. The position of the file tip inside the canal is shown in the display, and the motor stops or reverses rotation as soon as the file reaches the end of the working length to prevent over instrumentation. Also the auto start and stop function automatically starts the motor when the file is inserted into the canal and stops it when it is removed.

OAS (Optimum Apical Stop) Function

When the file reaches the end of the working length, it reverses slightly. This reduces the possibility of file jamming and separation.

Precise Manual Canal Measurement

Canals can also be measured manually. A file holder is provided. The ratio of the impedances of two different frequencies is calculated so that the location of the apex is determined with great accuracy regardless of whether the canal is wet or dry. The file tip location is clearly shown in an easy to read meter display. The combination of tactile feedback and the meter reading makes it easy to determine the location of the file tip. A beeping sound also acts as a guide to its location.

