



Root ZX3

INSTRUCTIONS FOR USE

HF Module



Thank you for purchasing the Root ZX3.

For optimum safety and performance as well as to avoid causing harm to people, read this user manual thoroughly before using the device and pay close attention to warnings and cautions. Keep this user manual in a readily accessible place for quick and easy reference.

* This device is the Root ZX3 HF module and it is designed to connect to only the Root ZX3 apex locator module.



Instructions for Use in Electronic Format (eIFU)

The electronic data (PDF document) of the Instructions for Use is available. Scan the following QR code and visit our website.



In order to view PDF documents, you will need the free Adobe Acrobat Reader distributed by Adobe Inc. Download the latest version via the Adobe website. PDF documents may not be displayed correctly using previous versions.

Trademarks and Registered Trademarks:

Parts of the names of companies, products, services, etc. used in this manual may contain either trademarks or registered trademarks owned by each company.

Table of Contents

1 Introduction	6
1.1 Customers	6
1.2 Dealers	6
1.3 Preventing Accidents	6
1.4 Disclaimer	7
1.5 In Case of Accident	7
2 Precautions	8
3 Intended Use	9
3.1 Intended Purpose	9
3.2 Indications for Use	9
3.3 User Qualifications (Intended Operator Profile)	9
3.4 Patient Population	9
3.5 Intended Environment	10
3.6 Contraindications, Warnings, and Considerations	10
3.7 Supposed Useful Life	10
4 Applicable Procedures	11
5 Parts Identification	12
5.1 Parts Identification and Display Screens	12
5.2 LCD Display and Switches	14
6 Usage	15
6.1 Set Up	15
6.1.1 HF Module Installation	16
6.1.2 Foot Switch Connection	17
6.1.3 HF Probe Cord Connection	18
6.1.4 Operation Check	20
6.1.5 Apex Location Accuracy Manual Check	22
6.2 Usage	23
6.2.1 Memory Numbers	23
6.2.2 Precautions for High-Frequency Conduction	24
6.2.3 Check Points before High-Frequency Conduction	26
6.2.4 High-Frequency Conduction (M2, M3, M4)	27
6.2.5 High-Frequency Conduction (M5)	35

6.3 After Use	39
6.3.1 Disconnecting the Cords and Removing Parts from the HF Module	39
6.3.2 Battery Pack Charging.....	40
6.4 Reprocessing	43
6.4.1 Parts to be Sterilized	45
6.4.2 Parts to be Disinfected	48
7 How to Modify Various Settings	50
7.1 Memory Contents	50
7.1.1 Editable Items and Default Settings	50
7.1.2 Procedures for M1, M2, M3, and M4	51
7.1.3 Procedures for M5	53
7.2 Other Functions.....	55
7.2.1 Editable Items and Default Settings	55
7.2.2 Procedures	55
7.3 Resetting the Default Settings.....	57
8 Troubleshooting	58
8.1 Troubleshooting.....	58
8.2 Error Numbers.....	61
9 Replacement Parts	62
9.1 Parts Replacement.....	62
9.1.1 Battery Pack Replacement.....	63
10 Electromagnetic Disturbances (EMD)	65
11 Technical Specifications	68
11.1 Specifications	68
11.2 Output Characteristic Curve	70
11.3 Symbols.....	71
12 Regular Inspection	72
12.1 Regular Inspection	72
12.1.1 Regular Inspection Items.....	72
13 Service and Disposal	74
13.1 Service	74
13.2 Standards and Procedures for Disposal of Medical Devices	74

1 Introduction

1.1 Customers

Make sure to obtain clear instructions concerning the various ways to use this device described in this accompanying user manual. Fill out and sign the warranty and give a copy to the dealer from whom you purchased the instrument.

1.2 Dealers

Be sure to give clear instructions concerning the various ways to use this device as described in this accompanying user manual. After instructing the customer in the operation of the device, have the customer fill out and sign the warranty. Then fill in your own section of the warranty and give the customer their copy. Be sure to send the manufacturer's copy to J. MORITA OFFICE.

1.3 Preventing Accidents

Most operation and reprocessing problems result from insufficient attention to basic safety precautions and not being able to foresee potential accidents. Problems and accidents are best avoided by foreseeing the possibility of danger and operating the device in accordance with the manufacturer's recommendations.

First, thoroughly read all precautions and instructions pertaining to safety and accident prevention. Then operate the device with the utmost caution to prevent either damaging the device itself or causing bodily injury.

Do not use the Root ZX3 for purposes other than its specified intended use in dental treatment.

The following symbols and expressions indicate the degree of danger and harm that could result from ignoring the corresponding instructions:

PROHIBITION

This indicates contraindications, related descriptions with operation and usage, as well as patients to whom this should not be applied due to their symptoms, underlying conditions, complications, anamnestic history, family history, or diathesis.

WARNING

This alerts the user of the possibility of extremely serious injury or complete destruction of the device, as well as other property damage including the possibility of fire.

CAUTION

This alerts the user of the possibility of minor or moderate injury or damage to the device.



This informs the user of important points concerning operation or the risk of device damage.

The user (e.g., healthcare facility, clinic, hospital, etc.) is responsible for the management maintenance and use of medical devices.

This device must not be used by anyone other than dentists, doctors, or other legally licensed professionals.

1.4 Disclaimer

J. MORITA MFG. CORP. will not be responsible for accidents, product damage, or bodily injury resulting from:

- (1) Repairs made by personnel not authorized by J. MORITA MFG. CORP.
- (2) Any changes, modifications, or alterations of its products.
- (3) The use of products made by other manufacturers, except for those produced by J. MORITA MFG. CORP.
- (4) Maintenance or repairs using parts or components other than those specified by J. MORITA MFG. CORP. and other than in their original condition.
- (5) Operating the device in a manner other than described in the operating procedures in this user manual or in a manner inconsistent with the safety precautions and warnings in this user manual.
- (6) Workplace, environmental, or installation conditions that do not conform to those stated in this user manual, such as an improper electrical power supply.
- (7) Fires, earthquakes, floods, lightning, natural disasters, or forces majeure.

1.5 In Case of Accident



If an accident occurs, this device must not be used until repairs have been completed by a qualified and trained technician authorized by the manufacturer.

2 Precautions

PROHIBITION

- Do not use this device on patient who has implanted a pacemaker or ICD (Implantable Cardiac Defibrillator). (May cause pacemakers and ICDs to malfunction.)
- This device is a dental electrosurgical unit. Do not use this device for purposes other than its specified intended use in dental treatment. Otherwise, it may result in unexpected health hazards.
- Do not use this device simultaneously with any other electrosurgical unit (hereafter “high-frequency treatment device”). Otherwise, it may result in burns due to high-frequency leakage, or malfunction by mutual interference.

WARNING

- Before using this device, be sure to fully understand the indications for use and operating principles, “Set Up” ( p. 15), “Usage” ( p. 15), “Memory Numbers” ( p. 23). Otherwise, it may result in unnecessary tissue destruction, protracted healing, accidents, or health hazards.
- No modification of this device is allowed.
- Do not perform maintenance while using this device for treatment.
- Do not use this device if the patient is connected to any other device except a biometric information monitor. Otherwise, it could result in malfunction or accidents.
- If a biometric information monitor is used simultaneously with this device, be sure to read the accompanying user manual for the biometric information monitor. If simultaneous use is unavoidable, monitor electrodes must be separated to the maximum possible extent from this device’s connection parts, such as the contrary electrodes, and sensor cables should be separated as far as possible from the HF probe cord. Moreover, avoid using needle-shaped monitor electrodes wherever possible, and be sure to use a biometric information monitor that is equipped with high-frequency current protection. There is a risk of burns due to unintended current pathways.
- Do not add in or connect this device to any other devices or systems except products designated by J. MORITA MFG. CORP.
- Always use the parts that are specially designed for this device. Never use any parts manufactured by other companies. Otherwise, it could result in malfunction or accidents.
- Illumination devices such as fluorescent lights and film viewers which use an inverter could cause this device to malfunction. Do not use this device near products such as these.
- Do not use the wireless transmission devices listed below in the patient examination area. Electromagnetic interference from such devices could cause this device to malfunction.
 - (1) Mobile phones and smart devices
 - (2) Wireless transmitting devices such as ham radios, walkie-talkies, and transceivers
 - (3) Personal Handy-phone System (PHS)
 - (4) Routers for intra-building paging systems, wireless LANs, analog cordless telephones, and other electric wireless devices
- Use only the battery pack designed for this device. If any battery pack other than the dedicated one is used, it could result in electric shock, fire, or device malfunction.
- Always wear personal protective equipment (PPE) such as safety glasses, gloves, a mask, etc. when using and reprocessing this device.

3 Intended Use

3.1 Intended Purpose

Electrosurgical procedures in oral cavity.

3.2 Indications for Use

The Root ZX3 device is a dental device with an apex locating function and an optional electrosurgical function and is composed of the aforementioned corresponding modules.

The apex locating function of Root ZX3 device is used for root canal measurement and working length determination.

The electrosurgical function is used for the following dental procedures: gingival incision and excision, gingivoplasty, gingivectomy, hemostasis, and excision of intraoral lesions. It is also used for the ablation of pulp, dental filling material (e.g., gutta-percha) and tissue in/around root canals as an adjunct to root canal therapy, after determining the tip position of the active electrode by apex location.

3.3 User Qualifications (Intended Operator Profile)

a) Qualification:

Legally qualified persons such as dentists for endodontic device and electrosurgical unit operation (it may differ among countries).

b) Education and Knowledge:

Have a good understanding of risks associated with root canal treatment.

It is also assumed the user is thoroughly familiar with root canal treatment including the prevention of cross-infection.

c) Language:

English and local language (Intended for professional use as described above)

d) Experience:

Persons with experience operating endodontic devices and electrosurgical units.

No special training is required except in cases where this is required by legal regulations of the relevant country or region.

3.4 Patient Population

CAUTION

- This device is not recommended for use in children under 12 years of age.
- Pay close attention to the patient during treatment with this device.

Age : Child (12 or older) to Elderly

Weight : Not applicable

Nationality : Not applicable

Sex : Not applicable

Condition : Conscious and mentally alert person. (Person who can stay still during treatment.)

3.5 Intended Environment

WARNING

- Do not use this device in areas with wet floors such as operating rooms. Do not use this device in areas that require asepticize. The Root ZX3 is not intended for use in such environment.

This device is used in general dental clinics and hospitals (= Professional healthcare facility environment), and the following environment is assumed:

- Non-sterile environment
- Normal room lighting
- Low-noise environment in which the sound emitted by this device is audible

Operating Environments

Temperature : +10°C to +35°C (+50°F to +95°F)

Humidity : 30% to 80% (without condensation)

Atmospheric Pressure : 70 kPa to 106 kPa

Transport and Storage Environments

Temperature : -10°C to +45°C (+14°F to +113°F)

Humidity : 10% to 85% (without condensation)

Atmospheric Pressure : 70 kPa to 106 kPa

- ! Do not expose the device to direct sunlight for an extended period of time.
- ! If the device has not been used for some time, be sure to charge the battery pack, and then check if the device works properly before using it again.
- ! Always remove the battery pack prior to storing or shipping the device.

3.6 Contraindications, Warnings, and Considerations

- Do not use this device on patient who has implanted a pacemaker, ICD (Implantable Cardiac Defibrillator), or artificial cochlear.

3.7 Supposed Useful Life

The useful life of the Root ZX3 is 6 years from the date of installation provided it is regularly and properly inspected and maintained.

4 Applicable Procedures

This device is a high-frequency treatment device intended for incision (excision and gingival retraction) and coagulation (cauterization and hemostasis).

This device can apply to the following dentistry fields.

Initial Treatment	Retreatment	Incision and Excision
<ul style="list-style-type: none"> • Dental pulp cauterization • Hemostasis 	<ul style="list-style-type: none"> • Cauterization of granuloma (inside and outside of the root canal) • Cauterization of infected tissue • Cauterization of contaminants 	<ul style="list-style-type: none"> • Gingival retraction • Gingival polyp

* The electrosurgical function can cauterize pulp during a pulpectomy.

* Do not use the electrosurgical function if you want to conserve vital pulp.

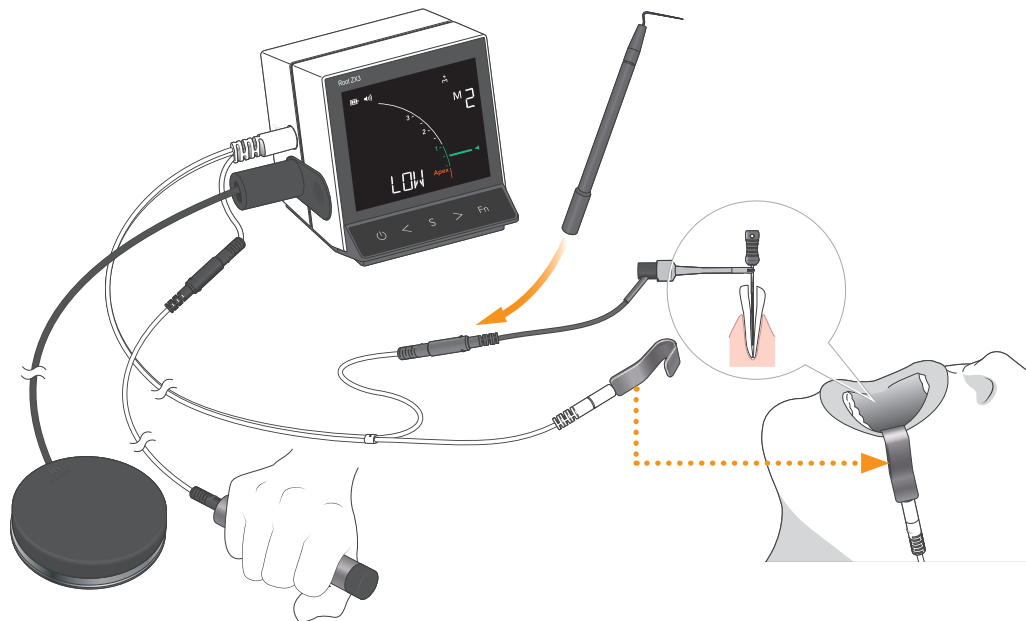





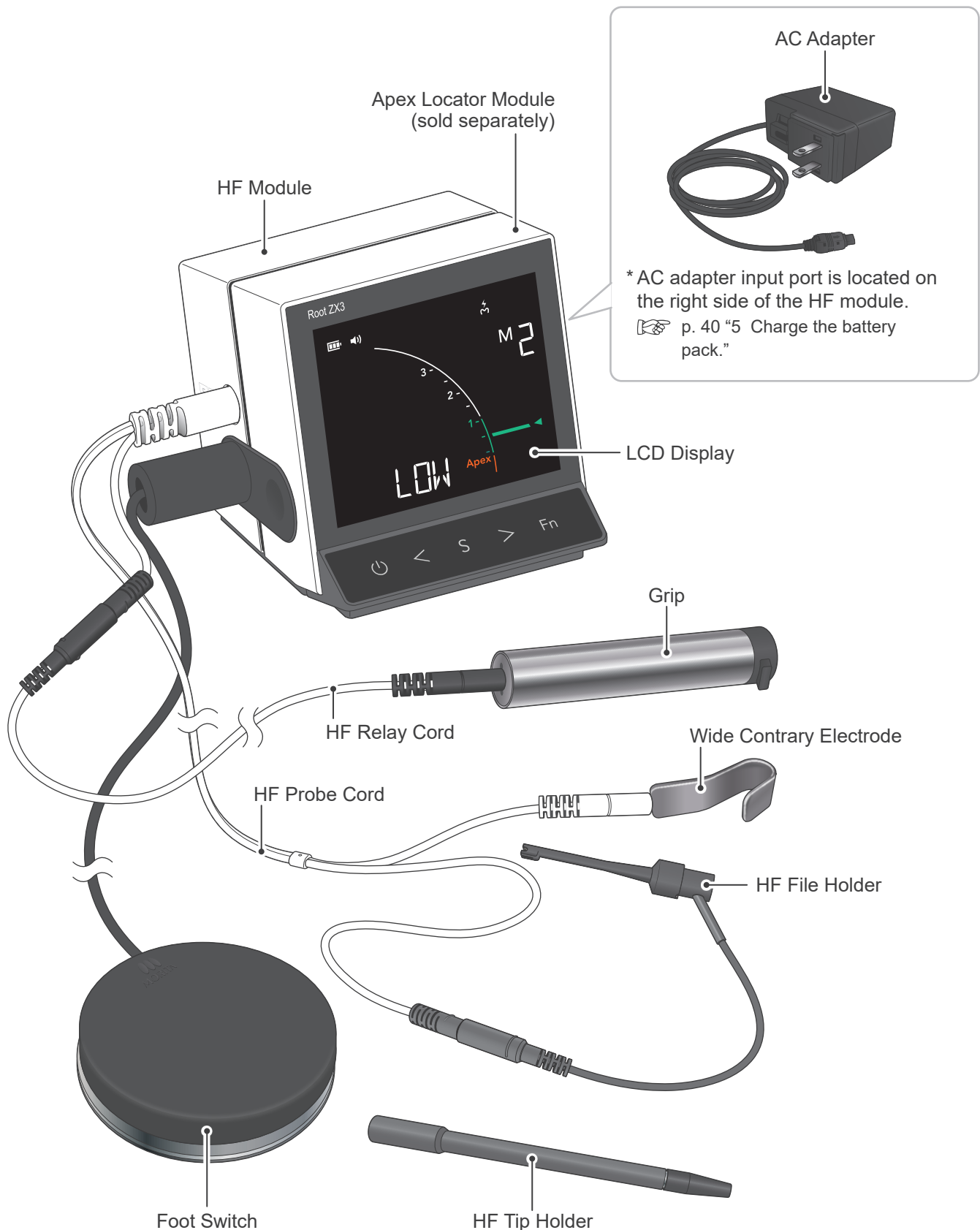



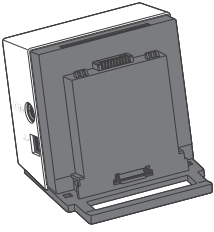
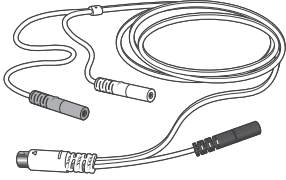

5 Parts Identification

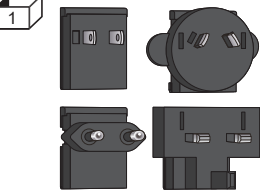
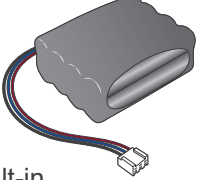

5.1 Parts Identification and Display Screens



■ Components



<p>HF Module</p>  <p>1</p>	<p>HF Probe Cord</p>  <p>1</p>	<p>HF Relay Cord</p>  <p>1</p>	<p>Foot Switch</p>  <p>1</p>
<p>AC Adapter</p>  <p>1</p>	<p>Power Plugs</p>  <p>* Each of 4 types</p>	<p>Battery Pack (nickel-metal hydride rechargeable battery)</p>  <p>* Built-in</p>	<p>Grip</p>  <p>1</p>
<p>Wide Contrary Electrodes</p>  <p>3</p>	<p>HF File Holders</p>  <p>3</p>	<p>HF Tip Holder</p>  <p>1</p>	<p>Cap</p>  <p>1</p>

● Electrode

<p>HF Files K#10L25</p>  <p>2</p>	<p>HF Endo Tips K#10</p>  <p>2</p>	<p>HF Cutting Tips No.1</p>  <p>2</p>
--	---	---

■ Sold Separately

● Electrode

<p>HF Files K#25L25</p>  <p>2</p>	<p>HF Endo Tips K#25</p>  <p>2</p>
--	---

5.2 LCD Display and Switches

LCD Display

Apex Location Indicator Bar

Indicates the location of the tip of the file or HF file.

Speaker Volume

You can adjust the speaker volume.

Battery Power

The number of bars show how much power is left.

! Charge the battery pack as soon as only one bar is displayed.

👉 p. 40

Meter Gauge

The numerals 1, 2, and 3 do not represent length in millimeters from the apex.

Use these numbers as an estimate only.

Current Indicator

The estimated output current will be displayed.

Message Indicator

- When M1 (EMR) is selected, this displays the number of bars left before the flash bar is reached.
- For M2 (LOW) through M5 (CUT.x), this displays the output result. 👉 pp. 33 and 37
- While Changing the Settings: Setting value is displayed.
- When an Error Occurs: Error number is displayed. 👉 p. 61

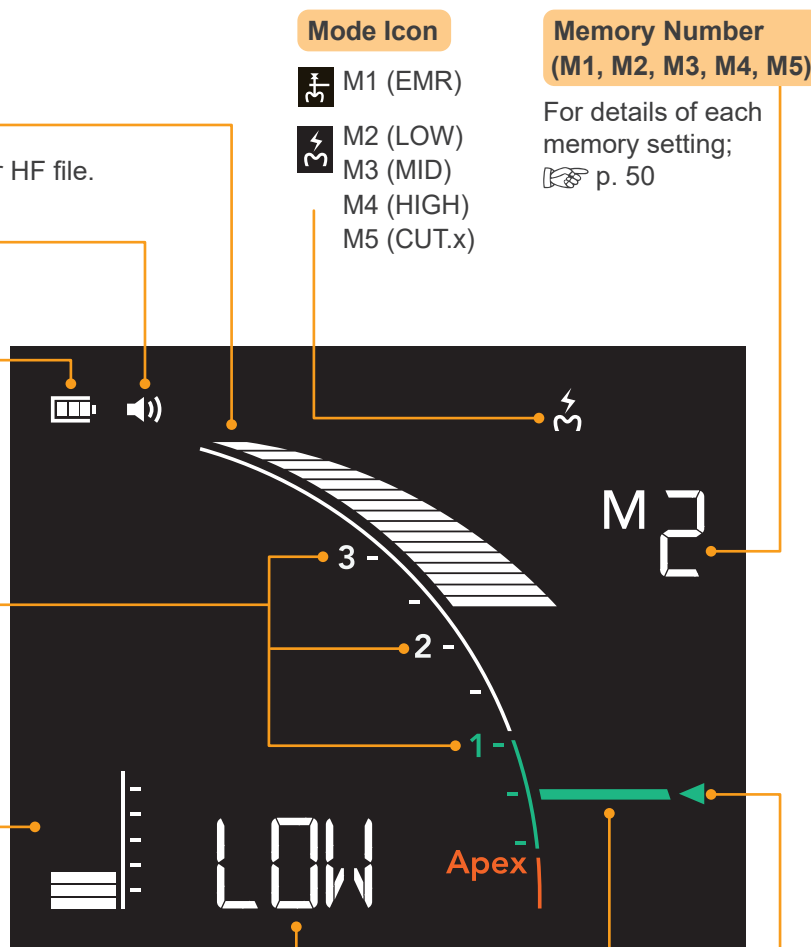

Flash Bar (FB)

Use this as an estimate position for the apex location or HF output. The flash bar can be set between meter reading 2 and the Apex.

* E.g., Flash bar 32 indicates the position of the apex location indication bar at 32nd from the top (meter gauge 0.5 ◀).

Meter Gauge	Flash Bar Display Value
2	FB.20
1	FB.28
0.5 ◀	FB.32
Apex	FB.36

0.5 Meter Reading

Switches

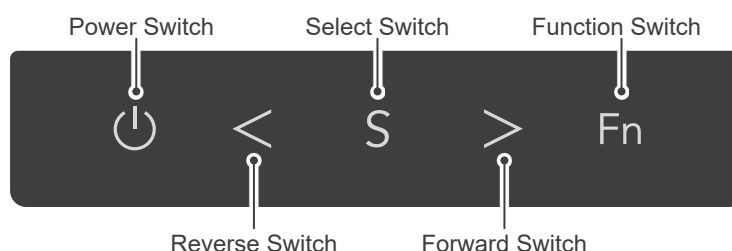

6 Usage

6.1 Set Up

WARNING

- Do not use this device if the patient is connected to any other device except a biometric information monitor. Otherwise, it could result in malfunction or accidents.
- If a biometric information monitor is used simultaneously with this device, be sure to read the accompanying user manual for the biometric information monitor. If simultaneous use is unavoidable, monitor electrodes must be separated to the maximum possible extent from this device's connection parts, such as the contrary electrodes, and sensor cables should be separated as far as possible from the HF probe cord. Moreover, avoid using needle-shaped monitor electrodes wherever possible, and be sure to use a biometric information monitor that is equipped with high-frequency current protection. There is a risk of burns due to unintended current pathways.
- Do not add in or connect this device to any other devices or systems except products designated by J. MORITA MFG. CORP.
- Always use the parts that are specially designed for this device. Never use any parts manufactured by other companies. Otherwise, it could result in malfunction or accidents.
- Illumination devices such as fluorescent lights and film viewers which use an inverter could cause this device to malfunction. Do not use this device near products such as these.
- Do not use the wireless transmission devices listed below in the patient examination area. Electromagnetic interference from such devices could cause this device to malfunction.
 - (1) Mobile phones and smart devices
 - (2) Wireless transmitting devices such as ham radios, walkie-talkies, and transceivers
 - (3) Personal Handy-phone System (PHS)
 - (4) Routers for intra-building paging systems, wireless LANs, analog cordless telephones, and other electric wireless devices
- Use only the battery pack designed for this device. If any battery pack other than the dedicated one is used, it could result in electric shock, fire, or device malfunction.

CAUTION

- When setting up the components, be sure not to contact the HF probe cord, HF file holder, and HF relay cord with other cords or cables.
- After wiping the parts with ethanol (70 vol% to 80 vol%), when you use them again, make sure that the disinfectant on the part surface is vaporized.



 Charge the battery pack before first use. The battery pack is not fully charged when the device is shipped from the manufacturer.

 p. 40 "5 Charge the battery pack."

 Be sure to perform the reprocessing procedures before using the parts for the first time.

 p. 43 "6.4 Reprocessing"

Check the following points before using the device.

- Have the autoclavable parts been autoclaved?
For details of autoclavable parts;  p. 45 "6.4.1 Parts to be Sterilized"
- Have the disinfectable parts been disinfected?
For details of disinfectable parts;  p. 48 "6.4.2 Parts to be Disinfected"
- Does the battery power indicator show sufficient remaining power?

6.1.1 HF Module Installation

! Do not drop the device or deliver a strong impact to it. These could result in malfunction or damage to the device.

1 Remove the dry battery housing.

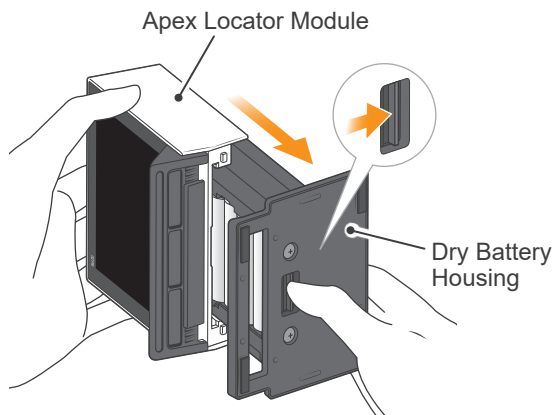

* Remove the dry batteries from the housing and store the housing under the specified environment.

👉 p. 10 "3.5 Intended Environment"

2 Install the HF module.

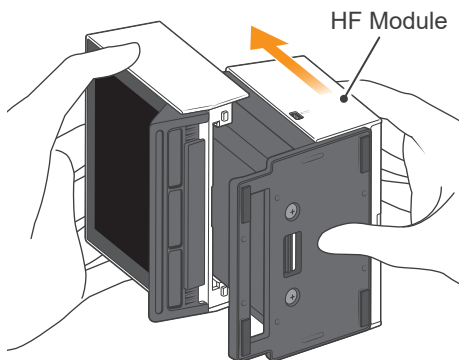

How to Remove the HF Module

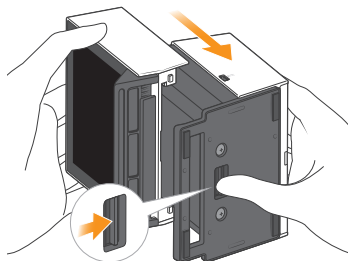

3 Plug the connection port on the apex locator module with the cap.

⚠ WARNING

- Always plug the connection port on the apex locator module with the accompanying cap and do not use the apex locator's probe cord when using the HF module. Otherwise, this could result in burns to the patient.

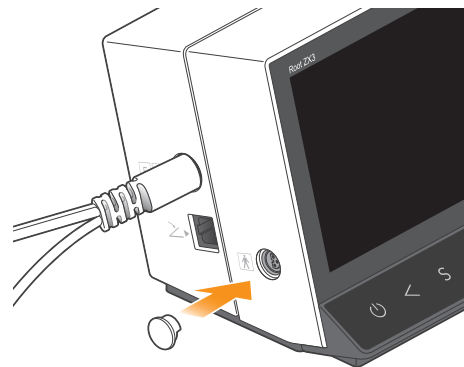
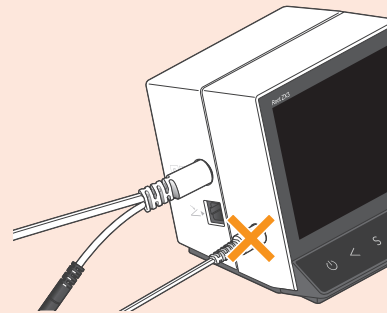

Plug the connection port on the apex locator module with the accompanying cap.

* The apex module's probe cord, file holder, and contrary electrode are not used with the HF module. Store them in the specified environment.

6.1.2 Foot Switch Connection

⚠ WARNING

- Make sure that the device is turned off when connecting the foot switch.
- Note that when the device is turned on, stepping on the foot switch will trigger and conduct a high-frequency. Also, be sure to turn the device off immediately when you finish using it.

- ! If the connections are loose and cords are easily disconnected, replace them with new ones.
- ! Do not hold the cord when connecting the foot switch to the device.
- ! Avoid strong impacts to the connection.
- ! Do not wind the foot switch cord around the device.

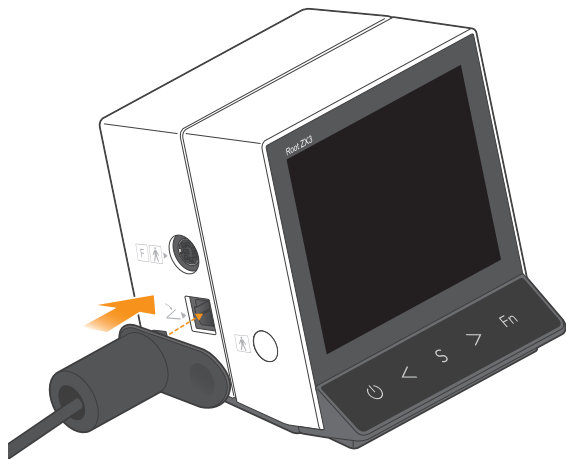

As shown in above illustration, align with the foot switch plug and the connection port on the left side of the HF module, and then insert the plug all the way.

6.1.3 HF Probe Cord Connection

- ! If the connections are loose and cords disconnect easily, discontinue use and replace them with new ones.

1 Connect the HF probe cord into the HF module.

⚠ WARNING

- Always plug the connection port on the apex locator module with the accompanying cap and do not use the apex locator's probe cord when using the HF module. Otherwise, this could result in burns to the patient.

⚠ CAUTION

- Make sure that the plug is connected into the connection port on the HF module all the way. If the plug is improperly connected, proper high-frequency output and accurate apex location cannot be made.

- ! Avoid strong impacts to the connection.
- ! Do not wind the HF probe cord around the device.

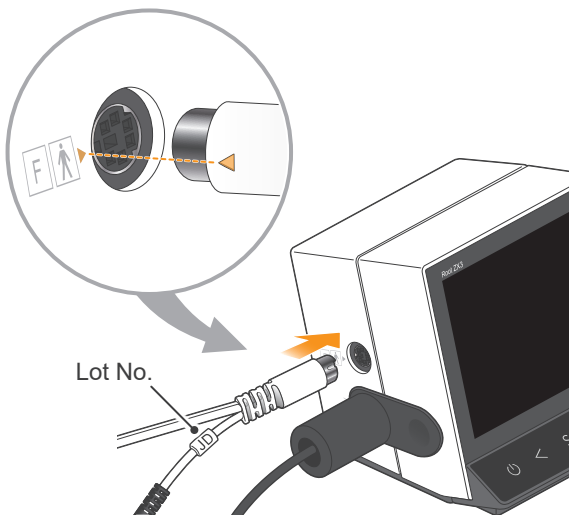

2 Connect the HF file holder or HF tip holder.

⚠ CAUTION

- Confirm the following point. If improperly connected, proper high-frequency output and accurate apex location cannot be made.
- Connect the HF file holder or HF tip holder to the HF probe cord's probe connector (gray).

- ! Never grip the probe cord when you connect the HF file holder or HF tip holder. As shown in the illustration below, always grip the connectors.

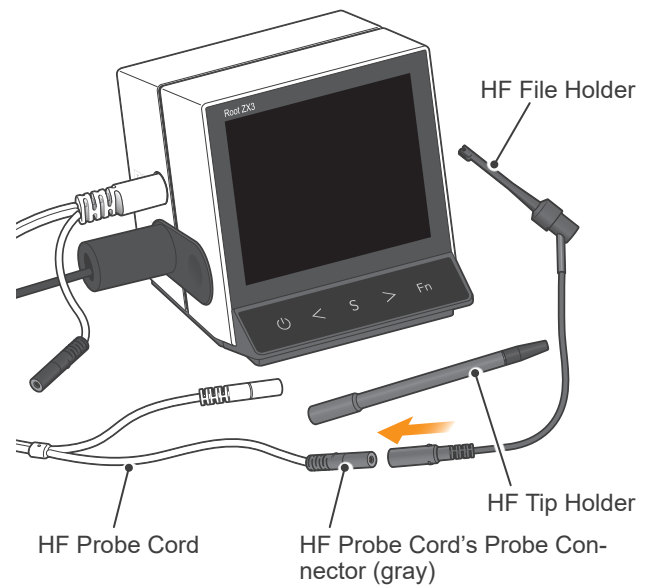
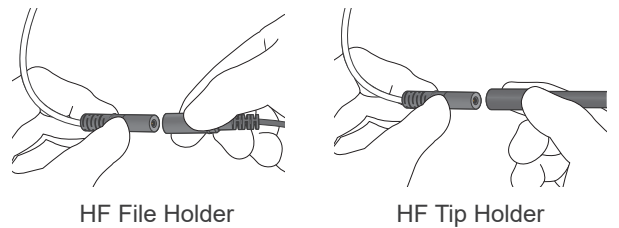

Connect the HF file holder or HF tip holder to the HF probe cord's probe connector (gray).

* Make sure to push it all the way in.

3 Connect the HF relay cord and grip.

⚠ CAUTION

- Confirm the following points. If improperly connected, proper high-frequency output cannot be made.
- Connect the HF probe cord's probe connector (black) to the HF relay cord.
- Connect the HF relay cord's probe connector (black) to the grip.

- ! Never grip the cord when you connect the HF relay cord or grip to the probe connector (black). As shown in the illustration below, always grip the connectors.

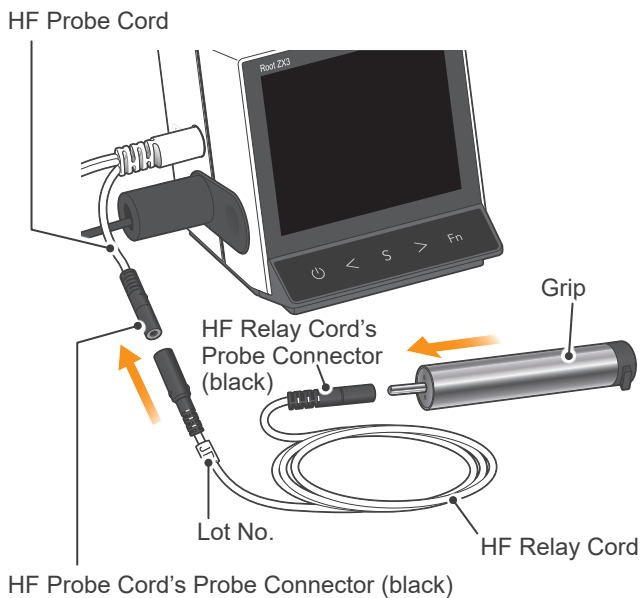
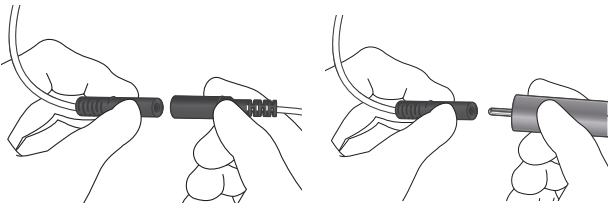

Connect the HF relay cord to the HF probe cord's probe connector (black).
Connect the grip to the HF relay cord's probe connector (black).

* Make sure to push it all the way in.

4 Connect the wide contrary electrode.

⚠ WARNING

- When using the HF module, always use the wide contrary electrode for apex location and high-frequency conduction. However, for M5 (CUT.x), do not connect the wide contrary electrode to the HF probe cord. Otherwise, this could result in burns to the patient.

⚠ CAUTION

- Confirm the following point. If improperly connected, proper high-frequency output and accurate apex location cannot be made.
- Connect the wide contrary electrode to the HF probe cord's probe connector (white).

- ! Never grip the cord when you connect the wide contrary electrode to the probe connector (white). As shown in the illustration below, always grip the connectors.

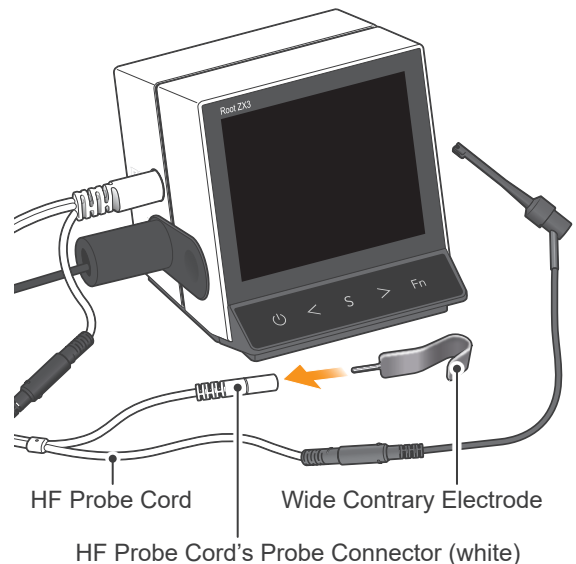
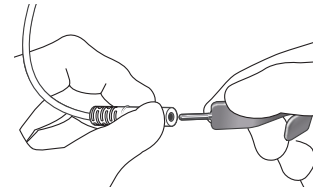

Connect the wide contrary electrode to the HF probe cord's probe connector (white).

* Make sure to push it all the way in.

6.1.4 Operation Check

⚠ CAUTION

- Check the Root ZX3's functionality before use with each patient.

1 Check the connections.

⚠ WARNING

- Confirm the following points. If improperly connected, unintentional current may be delivered and it can result in burns to you and the patient.
- Always plug the connection port on the apex locator module with the accompanying cap and do not use the apex locator's probe cord when using the HF module.
- Do not bundle up other cables and cords with the HF probe cord, or place close to them.

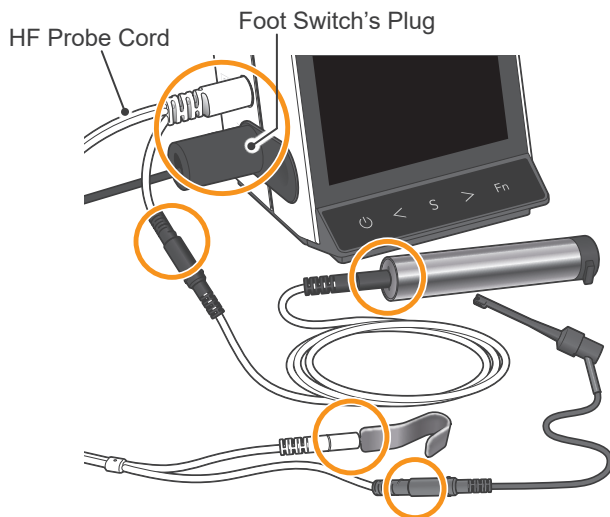

* Check the following points before turning on the device.

- Is the HF probe cord's plug connected to the HF module's connection port properly?
- Is the foot switch's plug connected to the HF module's connection port properly?
- Are the HF file holder, HF tip holder, HF relay cord, grip, as well as the wide contrary electrode connected to the probe connector properly?

2 Turn on the device.

⚠ WARNING

- Do not turn on the power while stepping on the foot switch.
- Make sure a short three-toned beep sounds when you press . If it does not, the device may be broken; you will not be able to recognize when the high-frequency is conducted and it is extremely dangerous. Stop using the device immediately and contact your local dealer or J. MORITA OFFICE.

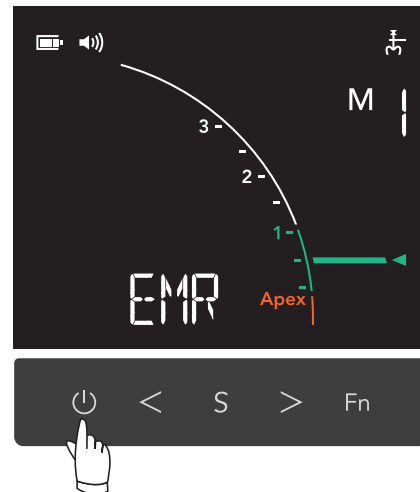

When is pressed, the Root ZX3 automatically confirms apex location accuracy.

If "ERR.0" is displayed, the apex location was not accurately confirmed. Stop using the device immediately and contact your local dealer or J. MORITA OFFICE.

* You can also hold down to check the apex location accuracy.

p. 22 "6.1.5 Apex Location Accuracy Manual Check"

3 Touch the wide contrary electrode with the HF file holder contact or HF endo tip.

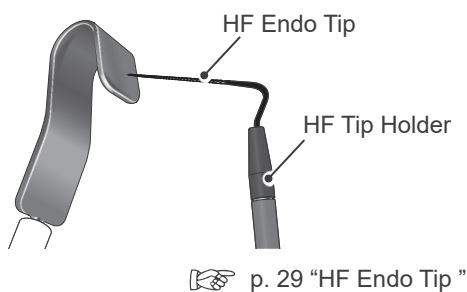
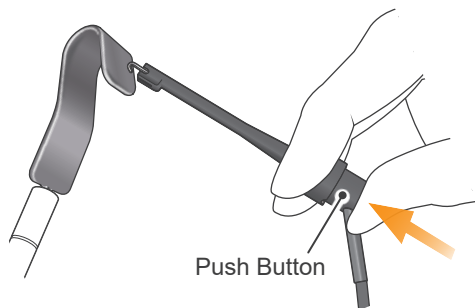

4 Check the LCD display.

⚠ CAUTION

- If all the apex location indicator bars do not light up, accurate apex location cannot be made. Stop using the device immediately and have it professionally repaired.

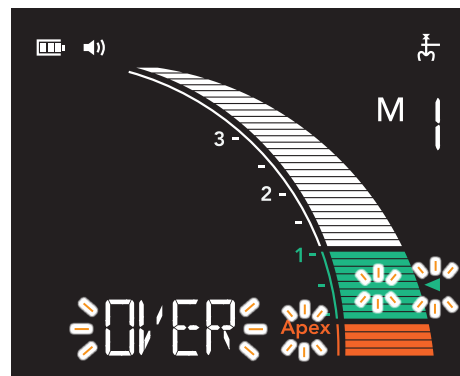

Confirm the following points:

- All the apex location indicator bars are lit up.
- "OVER", "Apex", and "◀" (0.5 meter reading) blink.
- A continuous beep sounds

6.1.5 Apex Location Accuracy Manual Check

1 Press the function switch.

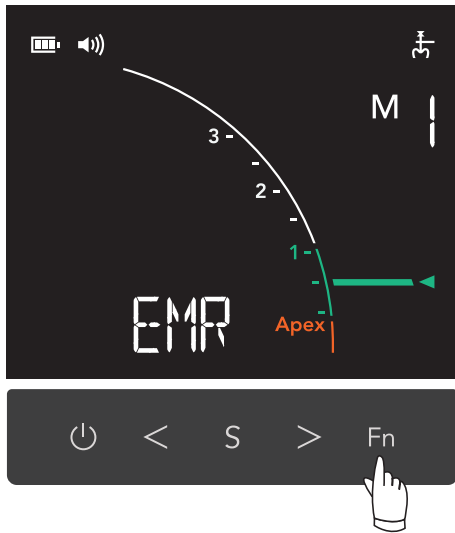

Hold down **Fn** for more than 1 second.

2 Accuracy check starts.

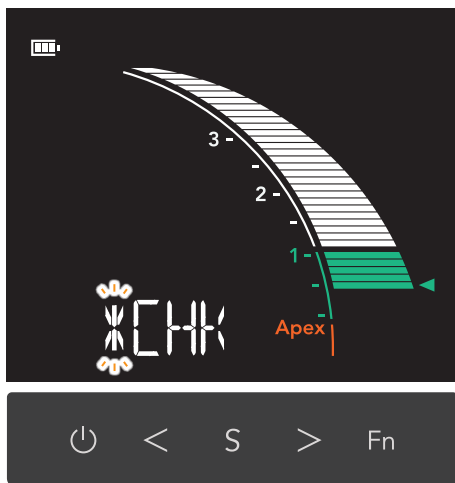

The message indicator displays “CHK” and accuracy check for the apex location will be made.

3 The result message is displayed.

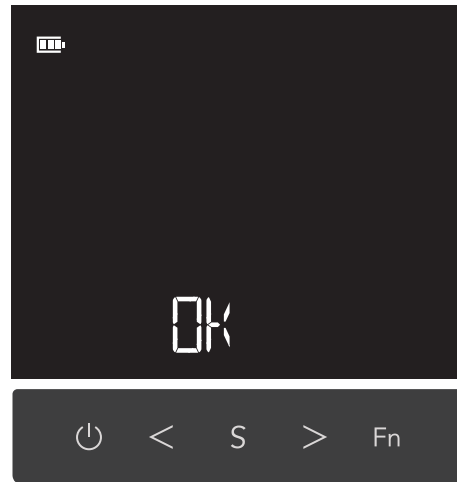

If the accuracy of the apex location is within the criteria, “OK” will be displayed. Then the display returns to the apex location screen automatically.

If “ERR.0” is displayed, the apex location was not accurately confirmed. Stop using the device immediately and contact your local dealer or J. MORITA OFFICE.

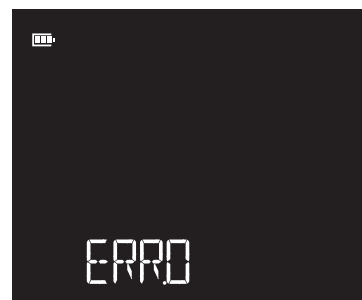

6.2 Usage

CAUTION

- These procedures are for the default settings. If you change the settings, use the device according to your own treatment procedures.
- When you change the memory contents, be sure to check the settings before using the device.

Select a memory number appropriate to the treatment to be performed.

The following explanation is based on the default settings.

6.2.1 Memory Numbers

The display, high-frequency conduction power, conducting time, flash bar position, and speaker volume of each memory number are listed below.

* For how to modify the default settings;

 p. 50 “How to Modify Various Settings”

* To revert the changes to their original default settings;

 p. 57 “7.3 Resetting the Default Settings”

Memory No.	M1	M2	M3	M4	M5
Display	EMR	LOW	MID	HIGH	CUT.x
High-Frequency Conduction Power	N/A* ¹	Low	Middle	High	CUT.1 to CUT.8 (variable)
Conducting Time	N/A* ¹	0.2 sec. × 5 times	1 sec.	1 sec.	Max. 10 sec.
Flash Bar Position	FB.32 (0.5 meter reading) (variable)				N/A* ¹
Speaker Volume	VOL.2 (variable)				

*¹ Items that you cannot set in the table above are indicated as “N/A”.

6.2.2 Precautions for High-Frequency Conduction

WARNING

- Before using this device, be sure to fully understand the indications for use and operating principles, “Set Up” (👉 p. 15), “Usage” (👉 p. 15), “Memory Numbers” (👉 p. 23). Otherwise, it may result in unnecessary tissue destruction, protracted healing, accidents, or health hazards.
- Do not apply the high-frequency repeatedly or continuously to the same position. Otherwise, these will result in damage to the contacting tissues, bones, or periodontal membrane.
- Excessive conduction inside the canal or beyond the apical foramen could result in damage to soft tissues, bones, and periodontal membranes, which may interfere with healing.
- Do not apply high-frequency conduction to deciduous teeth.
- Do not use M5 (CUT.x) inside the canal or beyond the apical foramen. Compared to other modes, M5 (CUT.x)’s electrical current is higher and the conducting time is longer. These may negatively affect the root canal, and its surrounding tissues and bones.
- If there is no bony defect at the apical foramen, avoid conducting high-frequency around the apical foramen.
- Do not use if the device is malfunctioning.
- Always perform checks before using;
👉 p. 26 “6.2.3 Check Points before High-Frequency Conduction”
- Do not use bent or worn active electrodes.
- Using these parts will result in the electric current being focused on the contacting position and burn or detrimentally affect the patient. Pay careful attention to the following points:
 - (1) The user, patient as well as helpers around them should not touch any metal parts (e.g., supporting parts of a treatment unit) that are conducting the floor or ground.
 - (2) The user, patient, as well as helpers around them must remove all metal accessories.
 - (3) When applying treatment around a metal crown, do not move the active electrodes closer to the crown.
- Before stepping on the foot switch, always make sure that the active electrodes are not contacting anything other than the treatment area.
- Do not apply high-frequency conduction while the active electrode (HF file or HF endo tip) is contacting the patient’s oral mucosa or skin. This could result in burns to the patient.
- Do not apply treatment to periodontal pockets. This could result in damage to the tissues.
- Do not apply directly to bones (e.g., alveolar bone) and periodontal membrane. This could result in damage to the tissues.
- If any other device is used simultaneously with the Root ZX3, be sure to read the accompanying user manual for the device. If using a device simultaneously with the Root ZX3, make sure that the device will not malfunction due to mutual interference from a high-frequency treatment device. This device uses high-frequency current and it may result in an electromagnetic affect with other medical electronic equipment. If this device is set up around a dental treatment unit, consider the installation place, using location, user position, etc. and make sure that everything may be operated safely. Also, take safety measures while using the device (e.g., turn off the dental treatment unit).
- Before use, remove combustible anesthetic or gas. Also, be sure to remove vaporized combustible gas including gas generated inside the body. These are extremely dangerous and can result in fire or explosion by sparks from the active electrodes.
- If there are combustible materials or liquid (e.g., alcoholic cleaning and disinfectant, tinctures, liquid bandage, bone cement, dried gauze), be sure to remove these through measures such as vaporizing before using the device. Pay close attention to not accumulate flammable solutions, especially beneath or in concave parts of the patient’s body. Even in normal use, sparks may be generated from the tip of the active electrodes. Sparks could be an ignition source and result in serious health damage such as burns to the patient or others.
- If the concentration of oxidizing gases (e.g., oxygen and nitrogen monoxide) is high in the location of use, provisionally reduce those concentrations before using the device. Oxygen and nitrogen monoxide (N₂O) can feed the fire to severe combustion; they are extremely dangerous.
- Do not use the device while the AC adapter is connected.
- When an HF file, wide contrary electrode, HF file holder, or HF tip holder is temporarily not in use, keep it away from the patient and place on an insulated instrument. This is especially important for the active electrodes immediately after use as they can result in burns to the patient or others as well as catch fire to dry cloth or gauze. Never place them directly on the patient’s body or on fabrics.
- Due to the risk of burns, place dry gauze or similar fabric between the patient’s skin surfaces (e.g., between the arm and torso).
- The patient may express pain because high-frequency conduction could stimulate the patient’s nerves and muscles. Before starting the treatment, apply an anesthetic as necessary. Also, explain to the patient that they may experience pain.

WARNING

- In principle, use a rubber dam to prevent accidental swallowing of an active electrode.
- Do not use excessive force to insert the active electrode into the canal. It may result in digging into the canal and breaking the active electrode. The active electrodes can easily break due to metal fatigue and excessive load.
- Do not contact grounded metal parts or metal parts that present a large capacitance against the ground (e.g., operating table's supporting frame) with the patient. Otherwise, the point of contact on the patient may be burned when high-frequency is conducted.
- When the device malfunctions, it may result in an unintended increase in high-frequency conduction.

CAUTION

- Do not touch the metal part of the HF file holder, HF file, or wide contrary electrode during the high-frequency conduction. You may burn yourself.
- Always check the memory number and its settings before use.
- Studies have shown that fumes produced by tissue cauterization contain harmful substances. When conducting the high-frequency, pay attention to the ventilation in the room and take measures such as wearing a mask with high particle removal capability, and use suction provided by the dental treatment unit.
- After wiping the parts with ethanol (70 vol% to 80 vol%), when you use them again, make sure that the disinfectant on the part surface is vaporized.
- Depending on the purpose of treatment, select a memory number and set high-frequency conduction power to achieve the minimum output power.
- If the message indicator displays "UNDR" while M2 (LOW), M3 (MID), or M4 (HIGH) is in use, make sure that the wide contrary electrode and grip are contacting properly with the patient before conducting high-frequency again.
- If the conduction power is too low or something is wrong while M5 (CUT.x) is in use, make sure that the patient holds the grip properly before increasing the conduction power.
- While the device is in use, the user must ensure that fingers are properly positioned. Also, wear gloves to ensure proper insulation from the patient. Otherwise, an unexpected accident may occur.
- Always clean the tip of the active electrodes as well as the clipping part of the HF file holder. If these parts are dirty, an insulating film will be generated on their surface and it could result in failure of high-frequency conduction.
- Do not use a bundled-up HF probe cord or HF relay cord. This could result in unstable high-frequency conduction.
- The tip of the active electrodes is sharp; handle with care.
- The active electrode may be hot immediately after high-frequency conduction. Wait for a few seconds when replacing the active electrode.

- ! While using the device, if the display is unstable or the device turns off on its own (except the auto power off function), stop using the device immediately and have it professionally repaired.

6.2.3 Check Points before High-Frequency Conduction

Inspect the following points before applying high-frequency conduction.

Inspection Items		Remedies	Ref. Page
1	Is there any debris on the HF file?	Replace it with a clean, sterilized one.	N/A
2	Is there any damage, wear, or bending on the HF file, HF file holder, HF tip holder, wide contrary electrode, or grip?	Replace the part with a new one.	N/A
3	Are the connectors (HF probe cord, HF relay cord, foot switch) properly connected? Is there any damage to cords?	Check the parts and connect them properly.	p. 17 p. 18
		If any abnormalities on the cord, replace it with a proper one.	N/A
4	Are the HF file holder, HF tip holder, wide contrary electrode, as well as the grip connected to the probe connector properly? Are they firmly connected?	Check the parts and connect them properly.	p. 18
		If connections are loose, replace the HF probe cord with a new one.	
5	Are there any combustible gases (e.g., inhalation anesthesia) accumulating or any ignitable materials around the operation area?	Provide adequate ventilation and remove combustible gases such as inhalation anesthesia.	p. 24
6	Is there any device in use that may cause the Root ZX3 to malfunction?	While the Root ZX3 is in use, take safety measures with other devices (e.g., turn the power off).	p. 24
7	Does the battery power indicator have more than two bars remaining?	Charge the battery pack as soon as the indicator gets down to only one bar.	p. 40
8	Does apex location properly work?	Confirm the following points: <ul style="list-style-type: none"> • All the apex location indicator bars are lit up. • “OVER”, “Apex”, and “◀” (0.5 meter reading) blink. • A continuous beep sounds. 	p. 21

6.2.4 High-Frequency Conduction (M2, M3, M4)

1 Turn on the device.

⚠ WARNING

- Do not turn on the device while stepping on the foot switch.



When is pressed, the Root ZX3 automatically confirms apex location accuracy.

If “ERR.0” is displayed, the apex location was not accurately confirmed. Stop using the device immediately and contact your local dealer or J. MORITA OFFICE.

* You can also hold down to check the apex location accuracy.

p. 22 “6.1.5 Apex Location Accuracy Manual Check”

2 Have the patient securely hold the grip.

⚠ WARNING

- Never place the connection part of the grip in contact with a power source (e.g., power outlet). This could result in an electric shock to you and the patient.
- Guide the patient to hold the grip with their palm. Partially holding the grip is not enough area for proper conduction and it could result in burns to the patient.

⚠ CAUTION

- Be careful not to drop the grip. If it drops on your foot, it may result in injury.

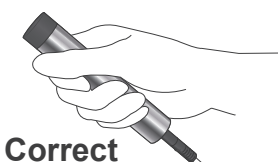

3 Hook the wide contrary electrode.

⚠ WARNING

- Never place the wide contrary electrode, HF file holder, or other connection parts in contact with a power source (e.g., power outlet). You could get an electric shock.
- Do not conduct high-frequency if only the wide contrary electrode is hooked in the patient’s mouth. Be sure to have the patient hold the grip.
- Make sure that the wide contrary electrode is properly touching the patient’s oral mucosa. Insufficient contact may result in burns to the patient.
- When using the HF module, always use the wide contrary electrode for apex location and high-frequency conduction. However, for M5 (CUT.x), do not connect the wide contrary electrode to the HF probe cord. Otherwise, this could result in burns to the patient.
- Make sure that the wide contrary electrode is properly touching the patient’s oral mucosa and there is no gap between the mouth and the wide contrary electrode. If the corner of the patient’s mouth is dry, try moistening it with a piece of gauze dampened with water. (Do not use ethanol [70 vol% to 80 vol%]; it will dehydrate.)

⚠ CAUTION

- The wide contrary electrode could cause an adverse reaction if the patient has an allergy to metals. Ask the patient about this before using the wide contrary electrode.
- Take care that medicinal solutions such as formalin cresol or sodium hypochlorite do not get on the wide contrary electrode or the HF file holder. These medicinal solutions could result in inflammation of tissues if they touch the patient’s skin or oral mucosa.

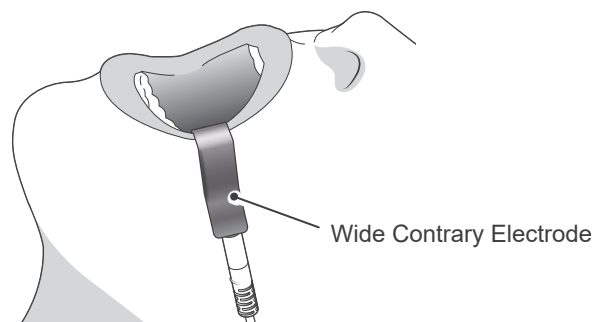

4 Clip an HF file or install an HF endo tip.

⚠ WARNING

- Be sure to clip or install the active electrode securely. If it is loose, the active electrode could come off and injure the patient.

⚠ CAUTION

- Do not conduct high-frequency while any liquid or moisture is on the HF file or HF file holder. This could result in burns to the patient.
- Be careful not to touch the metal part of the active electrode with your fingers. You may burn yourself when high-frequency is conducted.
- Never use damaged or deformed HF files, HF file holders, or HF tip holders. Otherwise, accurate high-frequency conduction cannot be made.
- Do not use HF files for apical patency or canal shaping. This will result in peeling off the file coating.

Guideline for Replacing HF Files

- When the file coating peels off approximately 10 mm or more from the file tip, replace it with a new one. The high-frequency conduction can be made even though the file coating is peeled off, but this may result in the current not being focused on the contaminants.

HF File Condition

Brand new file

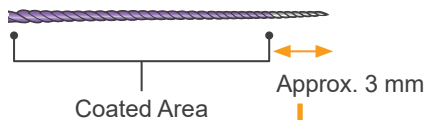

Needs to be replaced.

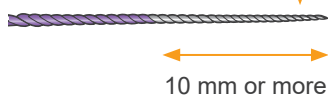

- For HF endo tips, when the coating (circled part as shown in the illustration below) is peeled off, replace the tip with a new one. Otherwise, the exposed area could be touched unintentionally and result in a current flow.

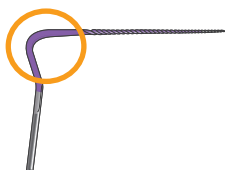

* The effect of high-frequency conduction is the same whether you use an HF file or end HF file.

● HF File



- ! Clip the HF file holder onto the metal upper part of the HF file (uncoated area close to the handle). Do not clip it onto the metal lower part (coated area) of the HF file. This will cause the coating to peel off, and metal and plastic parts of the HF file holder to wear out very quickly.

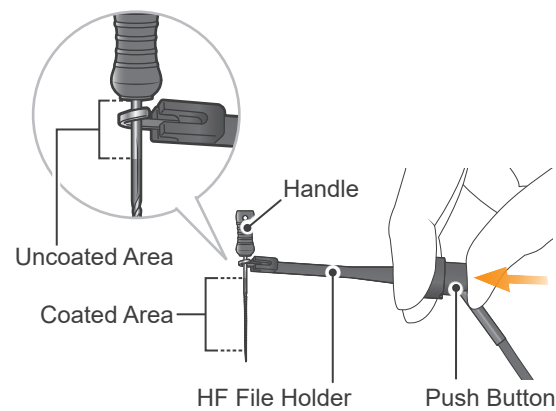

Push the button on the HF file holder with your thumb in the direction shown by the arrow in the illustration. Clip the HF file holder onto the metal upper part of the HF file (uncoated area close to the handle). Do not clip the coated area. The coated part is insulated.

⚠ CAUTION

- Do not clip the HF file as shown in figure 2. This will prevent accurate high-frequency conduction and will damage the tip of the HF file holder.

Correct

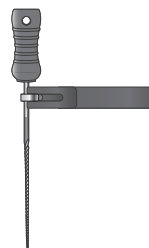

Figure 1

Incorrect

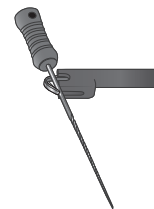
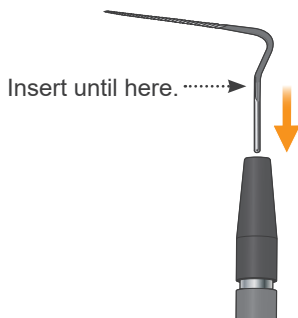

Figure 2

● HF Endo Tip



Loosen the HF tip holder by turning it about three rotations in the direction of the arrow.



Insert the HF endo file into the HF tip holder. Note that inserting it too shallowly may result in it becoming detached. Insert it all the way in.



Secure the HF endo file by turning the HF file holder in the direction of the arrow. Give the HF endo file a light tug to make sure it is properly fixed.

5 Select a memory number.

⚠ CAUTION

- Always check the settings of the selected memory before use.
- Depending on the purpose of treatment, select a memory number and set high-frequency conduction power to achieve the minimum output power.

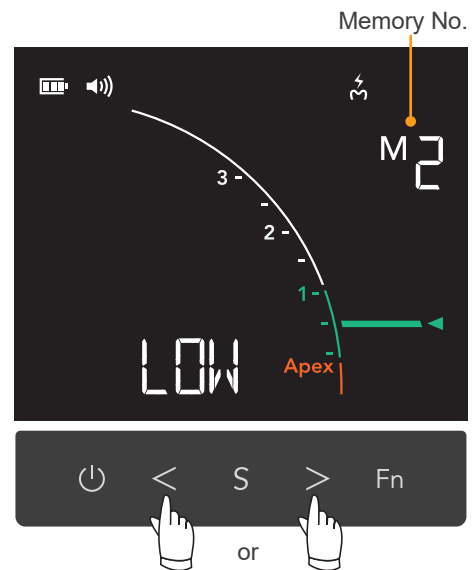

👉 p. 23 “6.2.1 Memory Numbers”

You cannot operate anything other than  during apex location and high-frequency conduction.

6 Determine the working position (conduction position).

⚠ WARNING

- Stop using the device immediately if it does not seem to be working properly.

⚠ CAUTION

- Accurate apex location may not always be possible, it depends on tooth condition, case complexity, as well as degradation of the device. Make sure to take an X-ray to check the results.

👉 “Root Canals Not Suitable for Electric Apex Location” chapter of the Apex Locator Module.

- If none of the apex location indication bar appears even when the active electrode is inserted, the device may be malfunctioning. Stop using the device immediately and contact your local dealer or J. MORITA OFFICE.
- Do not touch the gums with the active electrode. Working position (conduction position) cannot be determined correctly under such conditions.
- If the canal is too dry, the meter may not move until the active electrode is near the apex. If the meter does not move, stop the operation. Moisten the canal with oxydol (hydrogen peroxide) or saline, and then try to perform apex location again.
- After apex location, make sure to take an X-ray to check the results.

* Before conducting high-frequency, make sure that the mandibular canal or the mental foramen is not located in the vicinity of the electrode with X-ray or CT images. Otherwise, nerves or blood vessels may be damaged.

* The meter may make a sudden and large movement as soon as the HF file is inserted into the root canal, but it will return to normal as the file is

advanced down towards the apex.

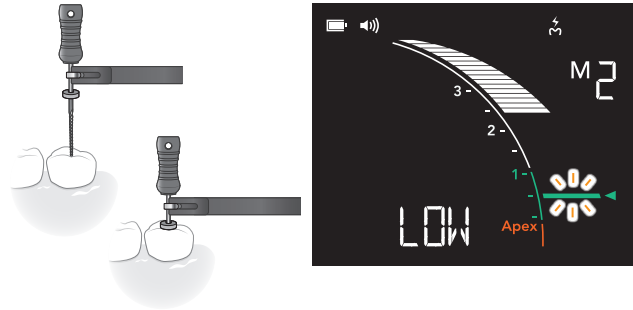

Insert the HF file into the root canal. Perform apex location and advance the HF file down the canal to the 0.5 meter reading point. Then position a rubber stopper on the surface of the tooth or other suitable point to serve as a reference.

Adjust the rubber stopper position according to the treatment procedures.

Apex location can not be performed with M5 (CUT.x).

7 Conduct high-frequency.

⚠ CAUTION

- Although it depends on the symptoms and treatment procedures, in principle, vacuum up any chemical solution or cleaning liquid inside the canal using suction from the dental treatment unit, and then, while the canal is slightly moistened, conduct high-frequency.
- Step on the center of the foot switch firmly to conduct high-frequency.
- Make sure that the file is not caught in the canal before conducting the high-frequency. Otherwise, the liquid inside the canal could boil suddenly and expel the liquid and contaminants outside the canal.
- If your finger is in contact with the metal part of the active electrode during high-frequency conduction, an electric current may flow into you.

● Before High-Frequency conduction screen

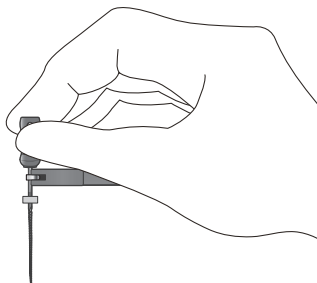
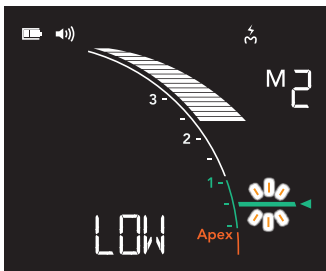

Hold the handle of the HF file between your fingers whenever possible.

* Holding the HF file with your fingers may not be stable for posterior teeth. Instead, use the HF file holder and hold the plastic part of it as shown in the illustration below. Be careful not to push the push button or dislocate the conduction position at this time.

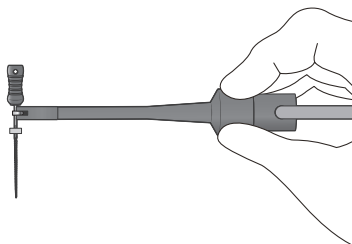

Step on the foot switch.

Apex location cannot be made while the foot switch is in use.

● During High-Frequency conduction screen

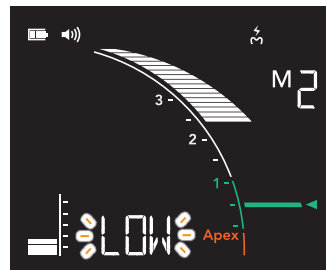

A beep will sound from the speaker. Keep stepping on the foot switch until the beep stops. If the switch is released while the beep still sounds, "FAIL" will be displayed in the message indicator.

☞ p. 34 "Did not complete successfully."

For each memory's conducting time, see the table below.

Memory No.	Conducting Time
M2	0.2 sec. × 5 times
M3	Max. 1 sec.
M4	Max. 1 sec.

* After a high-frequency conduction, it is not possible to re-conduct for approximately 2 seconds.

8 Turn off the device.

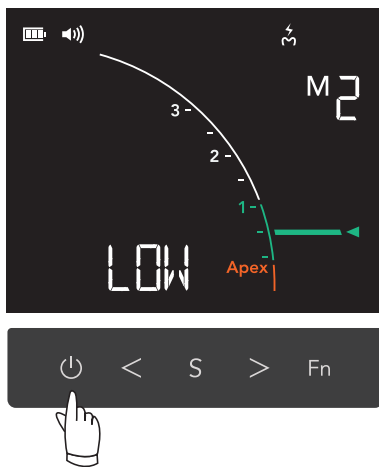

- Auto Power Off
If switches are not used for 10 minutes (default setting), the device will automatically turn off.
 p. 56 "Auto Power Off Time"

6.2.4.1 High-Frequency Conduction Result Screen (M2, M3, M4)

The Root ZX3 can check the high-frequency current and display the results.

■ Completed successfully:

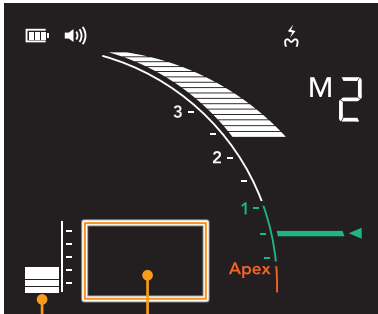

Message Indicator
Current Indicator

The result will be displayed in the current indicator for approximately 2 seconds.
If high-frequency conduction is completed with predetermined current, no message will be displayed in the message indicator.

■ If the conducted current was below the predetermined value:

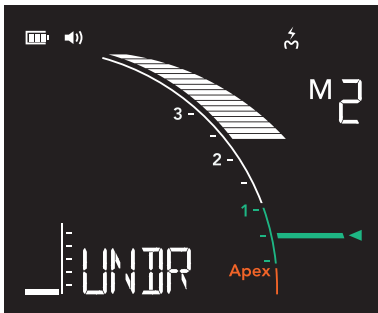

If high-frequency conduction is completed with lower value than the predetermined current, "UNDR" will be displayed in the message indicator. In this case, the high-frequency conduction has been completed, but to make it sure, perform high-frequency conduction again.
* "UNDR" will be displayed for approximately 5 seconds.

● Possible causes and remedies

Display	Possible Causes	Remedies
	The electric current did not flow well in the canal.	Clean the HF file and perform high-frequency conduction again.
	The battery pack is under-charged.	Clean the HF file and perform high-frequency conduction again. After that, if the battery indicator shows only one bar, charge the battery pack.
	The HF file holder is clipping the coated area of the HF file.	Clip the HF file holder onto the metal upper part of the HF file (uncoated area close to the handle), and then perform high-frequency conduction again.
	Insulated condition due to protein substances adhering to the surface of the HF file.	Clean the HF file or replace it with a new one, and then perform high-frequency conduction again.
	The wiring inside the HF probe cord is breaking.	Set the memory to M1 (EMR), touch the HF tip holder or HF file holder's contact with wide contrary electrode to check if all the apex location indicator bars light up. If they do not, have the device professionally repaired.

■ Did not complete successfully:

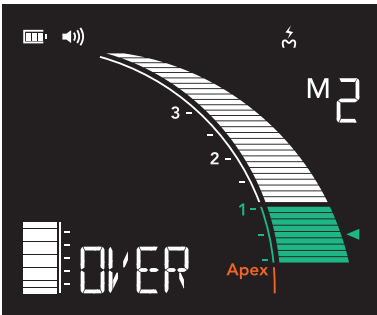

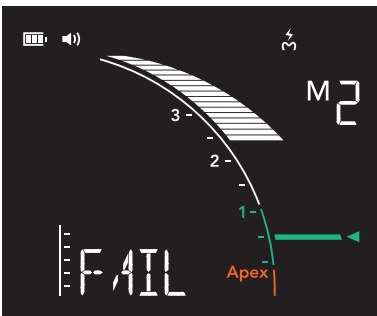

If high-frequency conduction was not completed successfully, either “OVER” or “FAIL” message will be displayed.

*“OVER” or “FAIL” message will be displayed for approximately 5 seconds.



● Possible causes and remedies

Display	Possible Causes	Remedies
	The electric current value flowed in the canal was too high.	High-frequency conduction could not be performed due to overcurrent detection. Move the conduction position towards the crown side and try again.
	Stepping on the foot switch too briefly.	Keep stepping on the foot switch until the beep stops.

■ Battery power information

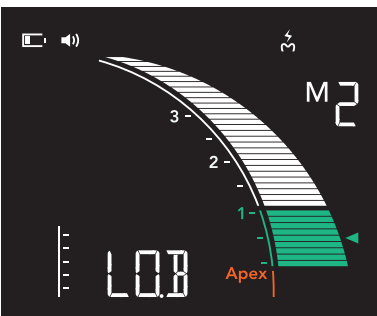

If high-frequency conduction was not completed successfully due to battery power, “LO.B” message will be displayed.

*“LO.B” will be displayed for approximately 5 seconds.

● Possible causes and remedies

Possible Causes	Remedies
The battery pack is under-charged or worn out.	Charge the battery pack or replace it with a new one.

6.2.5 High-Frequency Conduction (M5)

⚠️ WARNING

- For M5 (CUT.x), do not connect the wide contrary electrode to the HF probe cord. This could result in burns to the patient.
- Do not conduct the high-frequency inside the canal or outside the apical foramen. Compared to other modes, M5 (CUT.x)'s electrical current is higher and the conducting time is longer. These may negatively affect the root canal, and its surrounding tissues and bones.
- Be sure to have the patient hold the grip. Otherwise, high-frequency conduction will not be performed properly, and this will result in burns to you and the patient due to unintentional overheating of the parts.

1 Turn on the device.

⚠️ WARNING

- Do not turn on the device while stepping on the foot switch.

👉 p. 27 “1 Turn on the device.”

2 Have the patient securely hold the grip.

⚠️ WARNING

- Never place the connection part of the grip in contact with a power source (e.g., power outlet). This could result in an electric shock to you and the patient.
- Guide the patient to hold the grip with their palm. Partially holding the grip is not enough area for proper conduction and it could result in burns to the patient.

⚠️ CAUTION

- Be careful not to drop the grip. If it drops on your foot, it may result in injury.

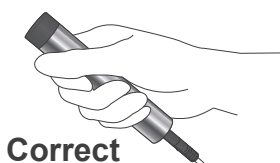

3 Clip an HF cutting tip.

⚠️ WARNING

- Be sure to clip or install the active electrode securely. If it is loose, the active electrode could come off and injure the patient.

⚠️ CAUTION

- Do not conduct high-frequency while any liquid or moisture is on the HF file or HF file holder. This could result in burns to the patient.
- Be careful not to touch the metal part of the active electrode with your fingers. You may burn yourself when high-frequency is conducted.
- Never use damaged or deformed HF files, HF file holders, or HF tip holders. Otherwise, accurate high-frequency conduction cannot be made.
- Do not use HF files for apical patency or canal shaping. This will result in peeling off the file coating.

● HF Cutting Tip No.1

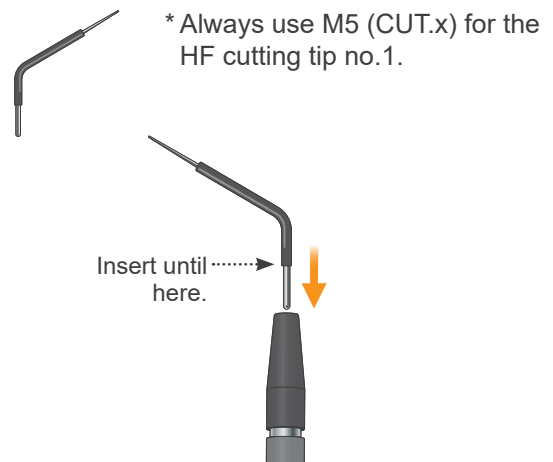

Insert the HF cutting tip into the HF tip holder. Note that inserting it too shallowly may result in it becoming detached. Insert it all the way in.



Secure the HF cutting tip by turning the HF file holder in the direction of the arrow. Give the HF cutting tip a light tug to make sure it is properly fixed.

4 Select M5.

⚠ CAUTION

- Always check the settings of the selected memory before use.
- Depending on the purpose of treatment, set the high-frequency conduction power to the minimum necessary.

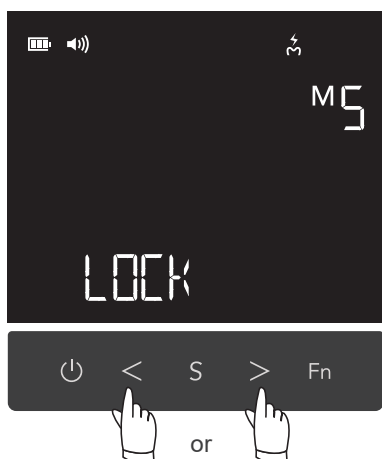

Press either **<** or **>** to select M5.

“CUT.5” and “LOCK” will be displayed alternately in the message indicator.

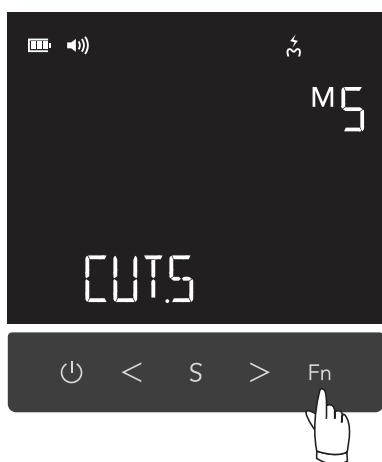

Press **Fn** to unlock the function.

When the message indicator displays only “CUT.5” (default setting), M5 is active.

You cannot operate anything other than **⏻** during high-frequency conduction.

5 Conduct high-frequency.

⚠ CAUTION

- Step on the center of the foot switch firmly to conduct high-frequency.

If the contrary electrode is hooked in the corner of the patient’s mouth, the “WARN” message will be displayed. Remove the contrary electrode to clear the “WARN” message and perform high-frequency conduction.



● Before High-Frequency Conduction screen



Step on the foot switch.

● During High-Frequency Conduction screen



The high-frequency is conducted while stepping on the foot switch (max. 10 seconds) and it stops when it is released.

* After a high-frequency conduction, it is not possible to re-conduct for approximately 2 seconds.

● High-Frequency Completion Screen (completed successfully)



No message will be displayed in the message indicator.

* If “OVER” or “LO.B” is displayed;

☞ p. 37 “6.2.5.1 High-Frequency Conduction Result Screen (M5)”

6 Turn off the device.

☞ p. 32 “8 Turn off the device.”

6.2.5.1 High-Frequency Conduction Result Screen (M5)

The Root ZX3 can check the high-frequency current and display the results.

■ Completed successfully:

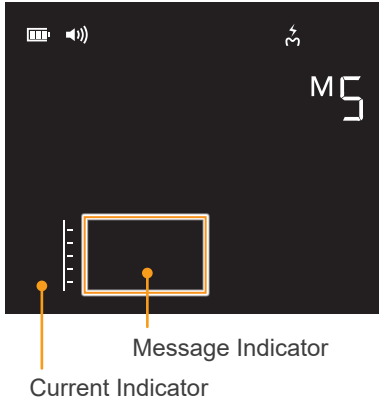

The result will be displayed in the current indicator for approximately 2 seconds.

If high-frequency conduction is completed with predetermined current, no message will be displayed in the message indicator.

■ If the current is too high:



If high-frequency conduction did not complete successfully due to overcurrent, the "OVER" message will be displayed.

* "OVER" will be displayed for approximately 5 seconds.

● Possible causes and remedies

Possible Causes	Remedies
The electric current was too high.	High-frequency conduction could not be performed due to overcurrent detection. Adjust the conduction position and try again.

■ Battery power information



If high-frequency conduction did not complete successfully due to battery power, "LO.B" message will be displayed.

* "LO.B" will be displayed for approximately 5 seconds.

● Possible causes and remedies

Possible Causes	Remedies
The battery pack is under-charged or worn out.	Charge the battery pack or replace it with a new one.

■ If the output power was too low against the predetermined value:

Possible Causes	Remedies
The HF file holder is clipping the coated part of the HF cutting tip.	Clip the HF file holder onto the metal upper part of the HF cutting tip (uncoated area close to the handle).
Insulated condition due to protein substances adhering to the surface of the HF cutting tip.	Clean the HF cutting tip or replace it with a new one and try again.
The grip is not contacting with the patient properly.	Have the patient securely hold the grip.
The wiring inside the HF probe cord is breaking.	Set the memory to M1 (EMR), touch the HF tip holder or HF file holder's contact with wide contrary electrode to check if all the apex location indicator bars light up. If they do not, have the device professionally repaired.
The wiring inside the HF relay cord is breaking.	Check if the current indicator moves during high-frequency conduction. If it does not move at all, have the device professionally repaired.

6.3 After Use

6.3.1 Disconnecting the Cords and Removing Parts from the HF Module

⚠ CAUTION

- After use, remove the components (HF file holder, HF tip holder, wide contrary electrode, grip) promptly from the patient.

1 Turn off the device.

👉 p. 32 “8 Turn off the device.”

2 Unclip the active electrode.

⚠ CAUTION

- Be careful when clipping and unclipping the HF files (installing and removing the HF endo tip) to avoid injury to fingers.

● HF Files

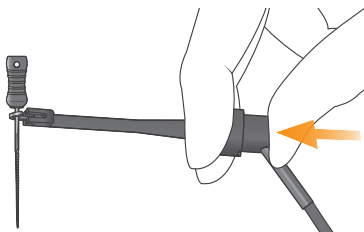

● HF Endo Tips & HF Cutting Tips

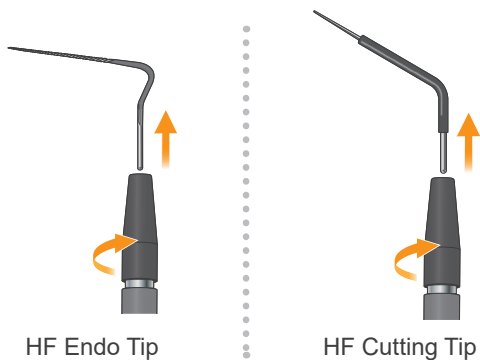

3 Disconnect the foot switch.

- ! Do not hold the cord when disconnecting the plug from the device.

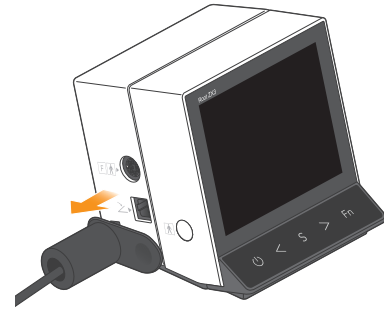

4 Disconnect the HF probe cord.

- ! Do not wind the HF probe cord around the device.
- ! Do not pull directly on the cords when disconnecting the HF file holder, HF tip holder, and wide contrary electrode from the probe connectors, as well as disconnecting the HF probe cord from the device. As shown in the illustration below, always grip the connectors to connect and disconnect parts.

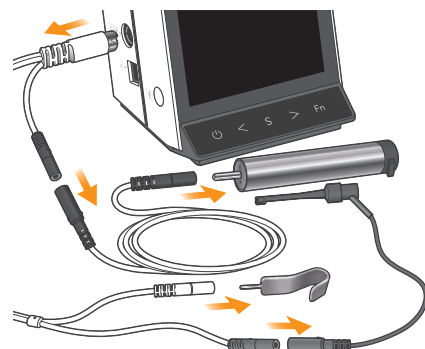
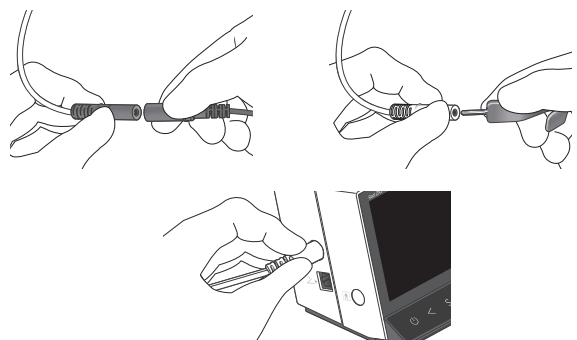

6.3.2 Battery Pack Charging

5 Charge the battery pack.

⚠ WARNING

- Always use the AC adapter that comes with the Root ZX3. Using another AC adapter can result in electric shocks, malfunctions, fires, etc.
- Do not touch the device or AC adapter if there is lightning while the battery pack is being charged. Otherwise, you could get an electric shock.

⚠ CAUTION

- Do not keep using the device when the battery power displays only one bar. Otherwise, proper operation and display cannot be made.
- When charging the battery pack, keep the device at least 1.5 m away from the dental treatment unit.

- ❗ Do not hold the cord when disconnecting the plug from the device.
- ❗ After finishing charging the battery pack, disconnect the AC adapter. Continuous charging the battery pack when it is fully charged may result in degradation of the battery pack.
- ❗ Unplug the AC adapter from the power outlet when the battery pack is fully charged.

* The Root ZX3 cannot be used while charging.

* The battery pack is mounted on the HF module.

Remaining Battery Power

The number of bars show how much power is left.

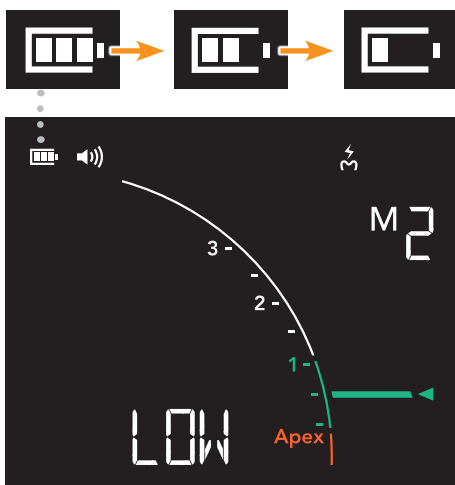



Charge the battery pack as soon as only one bar is displayed.

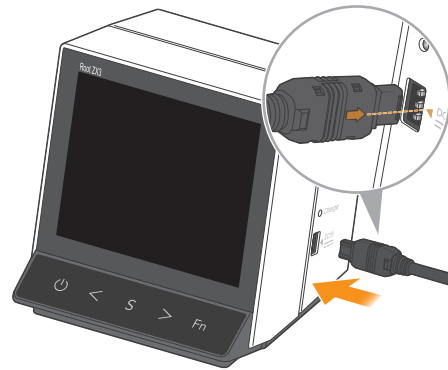

Press  to turn off the device.



Align the  mark on the AC adapter's plug and the  mark on the connection port on the right side of the HF module, and then insert the plug into the port all the way. Plug the AC adapter's power cord into the power outlet.

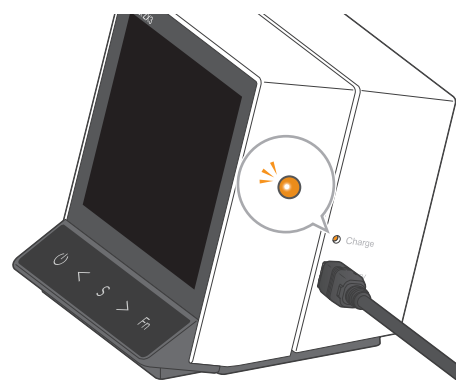

The charge LED (orange) located over the connection port will blink. After a few seconds, it will change to a steady light and the battery pack will start charging. It takes about 60 minutes to fully charge the battery pack.

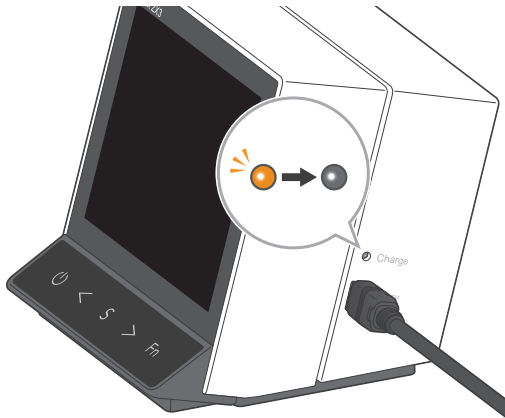

When the battery pack is fully charged, the charge LED will glow

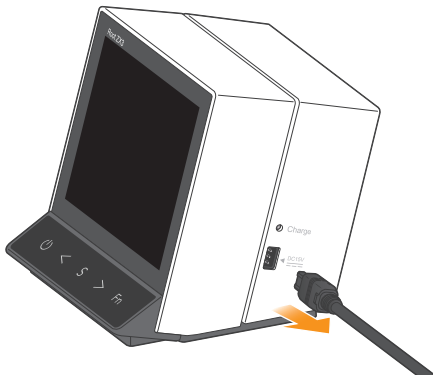



Disconnect the AC adapter's plug and power cord plug.

How to Ensure Good Battery Performance

- Charge the battery pack in an environment between +10°C and +35°C (+50°F and +95°F). Charging the battery pack outside this temperature range can result in reducing its performance and lifetime.
- Before using right after purchase, or if the device has not been used for an extended period of time, charge the battery pack first.
- The battery pack may lose its ability to hold a charge for the normal length of time if it has not been used for a long time or if it is recharged before each use. This is due to its deactivation (dull charging response) or to what is called the “memory effect”.

- * Sometimes the battery pack may recharge more quickly than usual. If the time it takes for recharging the battery seems too short, check the battery power on the LCD display, recharge it if the indicator shows less than two bars.
- * If the device will not be used for an extended period of time, it is recommended that you remove the battery cover on the back of the device and disconnect the battery pack, and then store the battery pack. This can reduce wear on the battery pack.
- * Replace the battery pack with a new one if it seems to be running out of power sooner than it should.
 ☞ p. 63 “9.1.1 Battery Pack Replacement”

When  is pressed, the Root ZX3 automatically checks its battery degradation. If the device detects battery degradation, “CHANGE BATTERY” will be displayed in the message indicator and a two-toned beep will sound five times. Replace the battery pack with a new one immediately.

If “ERR.G” is displayed in the message indicator after pressing , the battery pack is severely degraded and the device cannot be used.

■ Using and handling the power plug for the AC adapter.

⚠ WARNING

- Make sure the power plug is properly and securely installed.
- Never plug in a power plug alone without installing it. This will result in an electric shock.

The main plug for the AC adapter is not connected when the Root ZX3 is shipped.

Four types of plugs are provided as shown below. Select the one suitable for your region.

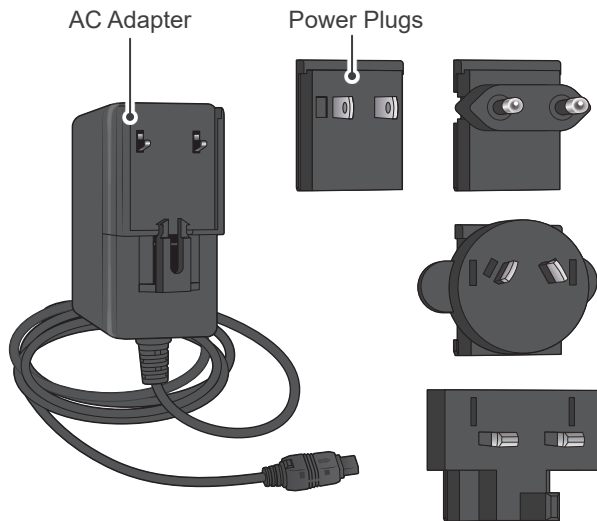

● Connect Power Plug

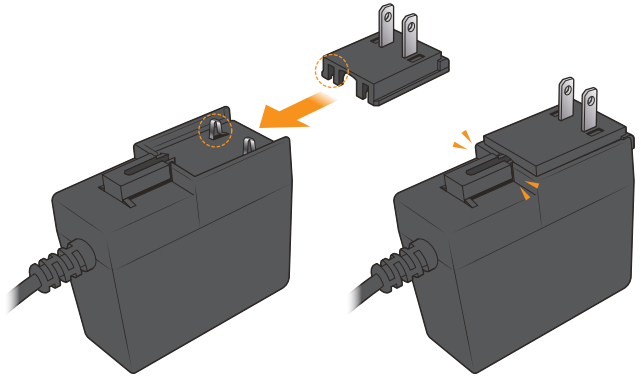

● Disconnect Power Plug

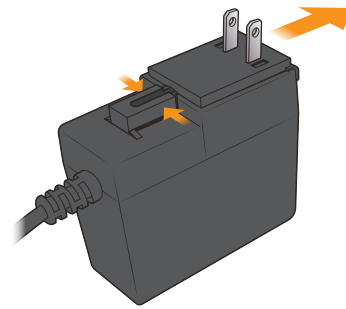

6.4 Reprocessing

Even items designed to be reusable may need to be treated as single patient use or single use and disposed of. Use in accordance with the laws and local regulations of the country or region in which it is used.

Hygiene Plan Guidebook

A reference guidebook of hygiene information about our products is available. Scan the following QR code and visit our website.



In order to view PDF documents, you will need the free Adobe Acrobat Reader distributed by Adobe Inc. Download the latest version via the Adobe website. PDF documents may not be displayed correctly using previous versions.

There are two ways to perform reprocessing depending on the items.

6.4.1 Parts to be Sterilized

p. 45

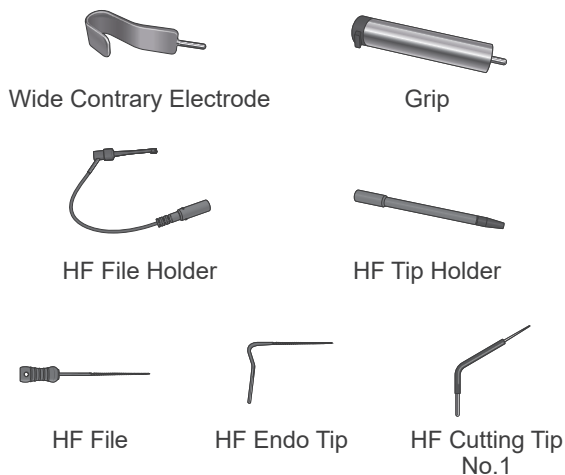

6.4.2 Parts to be Disinfected

p. 48

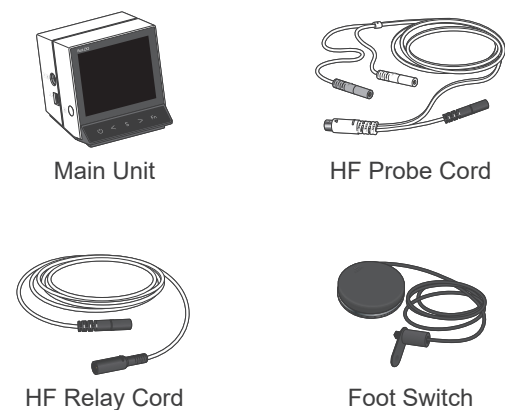

WARNING

- To prevent the spread of infections, be sure to perform the reprocessing procedures after use with each patient.
- Be careful to avoid cross infection when performing reprocessing.
- Always wear personal protective equipment (PPE) such as safety glasses, gloves, a mask, etc. when performing the reprocessing procedures.

CAUTION

- When performing reprocessing, always turn off the device and disconnect the AC adapter from the device. Make sure that the device remains off until work is complete.
- Be careful when clipping and unclipping the HF files (installing and removing the HF endo tip) to avoid injury to fingers.

After use, perform reprocessing promptly.

Before reprocessing, make sure that the active electrodes are removed from the HF file holder or HF tip holder.

■ Preparation

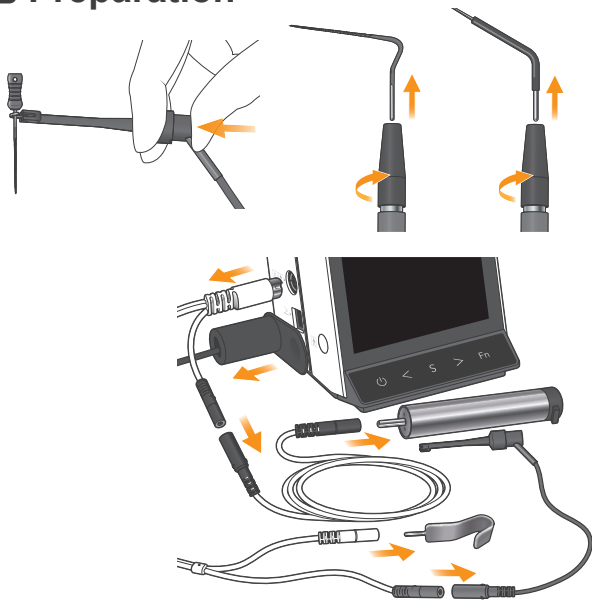

 p. 39 "6.3 After Use"

6.4.1 Parts to be Sterilized

* Be sure to perform the reprocessing procedures in the following order after use with each patient.

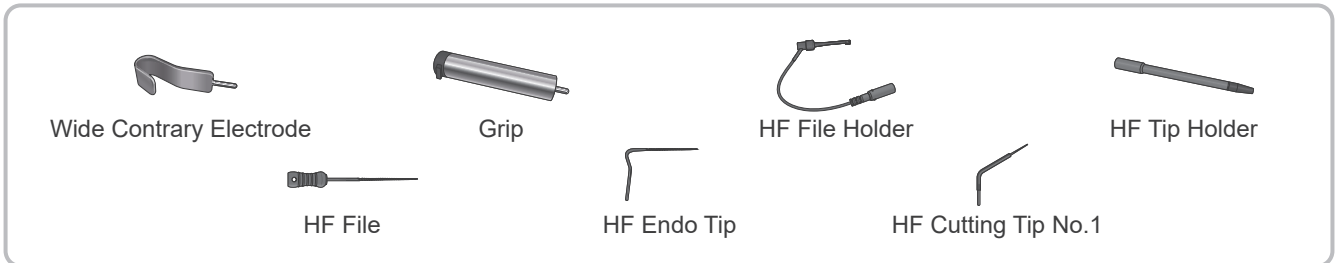

1 Pre-treatment

This must be performed after use with each patient.

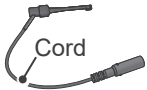
- ❗ After use, perform reprocessing promptly. If the parts are left contaminated with blood, it will be difficult to remove.
- ❗ Do not use any chemicals that may coagulate proteins before cleaning.
- ❗ If a medical agent or adhesive material being used for the treatment has adhered to the component, wash it off in running water.
- ❗ Be careful not to tug on the cord when you clean the HF file holder. This could cause the wire to break. 
- ❗ Do not wipe the coated area of the active electrode strongly. This will result in peeling off the coating.
- ❗ Do not clean the parts with an ultrasonic cleaning device.

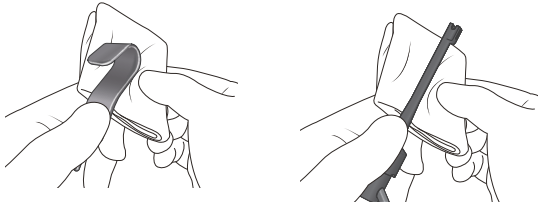

Wipe the parts with a piece of gauze or microfiber cloth (e.g., Toraysee for CE - Medical Equipment and Instruments Maintenance Cloth) that has been dampened with tap water to remove visible contaminants.

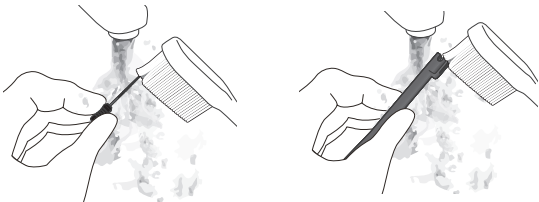

Alternatively, clean the parts in running water with a soft brush to remove visible contaminants.

2 Cleaning & Disinfection

⚠ WARNING

- If any moisture is left inside the parts after cleaning, it could cause corrosion or poor sterilization. Also, the remaining water may come out during use. After cleaning, use a syringe or compressed air to expel remaining moisture.

⚠ CAUTION

- Dust and other impurities adhering to the file holder's electrical contacts or hook can cause the device to malfunction.

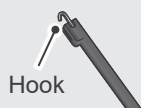

- ❗ Be sure to remove visible contaminants before this step. 🖱️ "1 Pre-treatment"
- ❗ Be sure to use washer-disinfectors that conform to ISO 15883-1 (must be capable of achieving disinfection values of not less than $A_0 = 3000$).
- ❗ If your region is susceptible to hard water scale buildup, use deionized water (ion-exchanged water).
- ❗ For details on handling detergents and neutralizers, concentration, water quality as well as parts washing baskets, refer to the accompanying user manual for the washer-disinfector.
- ❗ For cleaning and disinfection the active electrodes, use a fine-meshed washing baskets.
- ❗ Inappropriate cleaning methods and solutions may damage the parts.
- ❗ Do not use strong acidic or alkaline chemicals that could cause the metal to corrode.
- ❗ Do not start drying when the interior of the part is filled with water. Otherwise, this could result in corrosion of the part due to condensation of the rinsing solution.
- ❗ After completing the cleaning process, expel remaining moisture inside the parts with compressed air.
- ❗ Do not leave the parts in the washer-disinfector. This may cause corrosion or malfunction of the parts.
- ❗ Parts' surface may get scratched and wear out during the cleaning process due to contact with the parts washing basket or other parts. Replace the parts as necessary depending on degree of scratches and wear.



Recommended Conditions for Washer-Disinfectors

Unit Name	Miele G7881
Mode	Vario TD (cleaning time: 5 minutes)
Detergent (concentration)	neodisher MediClean (0.3% to 0.5%)
Rinse (concentration)	neodisher MediKlar (0.03% to 0.05%)

Put parts in the parts washing basket.

Select the washer-disinfector's mode as shown in the table above and start the process.

After completing the cleaning process, make sure the parts are thoroughly clean.

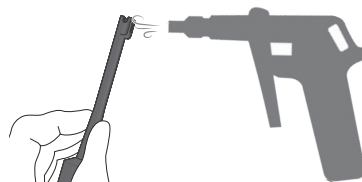

Expel remaining moisture on the surface or inside the parts with compressed air.

3 Packaging

- ❗ Use sterilization pouches that conform to ISO 11607.
- ❗ Do not use any sterilization pouches that contain hydro-soluble adhesive ingredients such as PVA (polyvinyl alcohol).
- ❗ Note that even ISO 11607 conformable sterilization pouches may contain PVA.
- ❗ When placing a part in a sterilization pouch, be sure not to put stress on the part (e.g., cord).

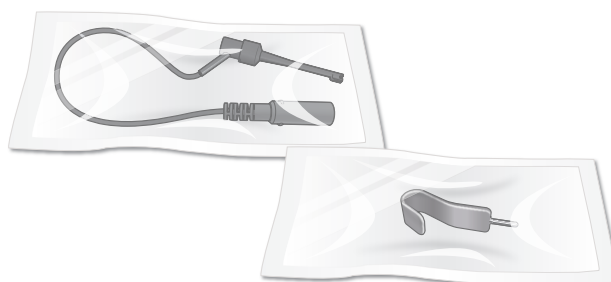

Place the parts individually in a sterilization pouch. Use only FDA-cleared pouches. (Only for U.S.A.)

4 Sterilization

⚠ WARNING

- To prevent the spread of infections, the parts must be autoclaved after each patient's treatment has been completed.

⚠ CAUTION

- Parts are extremely hot right after autoclaving. Wait for them to cool off before touching.
- Note that especially for the grip, it is hard-to-cool and needs more time compared to other parts.

- ❗ Do not sterilize the components by any method other than autoclaving.
- ❗ If chemical solutions or foreign debris are not removed, autoclaving could damage or discolor the component. Thoroughly clean and disinfect the components before autoclaving.
- ❗ The setting temperature for sterilization and drying process must be +135°C (+275°F) or lower. If the temperature is set at beyond +135°C (+275°F), it may cause a malfunction or stain on the parts.
- ❗ Do not autoclave any parts other than the wide contrary electrode, grip, HF file holder, HF tip holder, and active electrodes.
- ❗ Take the active electrode out of the HF file holder or HF tip holder before autoclaving.
- ❗ The color of the active electrodes' coating may fade and transfer to other parts. Replace the parts as necessary depending on degree of color fading and coating wear.  p. 28 "Guideline for Replacing HF Files"
- ❗ After completing the autoclaving process, do not leave the parts in the autoclave.

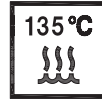

Recommended Autoclave Settings

Country: U.S.A.

Sterilizer Type	Temperature	Time	Drying Time after Sterilization
Gravity	+132°C (+269.6°F)	15 minutes	15 minutes
	+121°C (+249.8°F)	30 minutes	

Country: Other than U.S.A.

Sterilizer Type	Temperature	Time	Drying Time after Sterilization
Dynamic Air Removal	+134°C (+273.2°F)	3 minutes	10 minutes
	+134°C (+273.2°F)	5 minutes	
Gravity	+134°C (+273.2°F)	Min. 6 minutes	Min. 10 minutes
	+121°C (+249.8°F)	Min. 60 minutes	

Autoclave the autoclavable parts.

After autoclaving, store the parts in a clean and dry environment.

6.4.2 Parts to be Disinfected

* Be sure to perform the reprocessing procedures in the following order promptly after use with each patient.

Pre-treatment → Cleaning & Disinfection



Main Unit

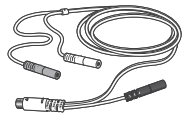

HF Probe Cord



HF Relay Cord



Foot Switch

1 Pre-treatment

- ❗ After use, perform reprocessing promptly. If the parts are left contaminated with blood, it will be difficult to remove.
- ❗ Do not use any chemicals that may coagulate proteins before cleaning.
- ❗ If a medical or adhesive agent being used for the treatment has adhered to the part, immediately remove it with a piece of gauze or microfiber cloth (e.g., Toraysee for CE - Medical Equipment and Instrument Maintenance Cloth) that has been dampened with tap water.
- ❗ Be sure not to tug on the cable or cord when you clean the parts. This could cause the wire to break.
- ❗ Do not clean the parts with an ultrasonic cleaning device.
- ❗ Do not wet the electrical contacts.

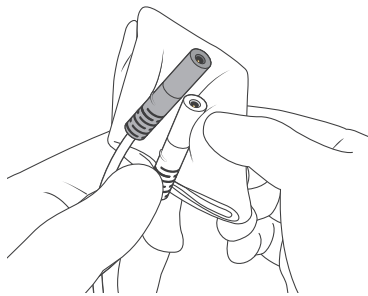

Wipe the parts with a piece of gauze or microfiber cloth (e.g., Toraysee for CE - Medical Equipment and Instruments Maintenance Cloth) that has been dampened with tap water to remove visible contaminants. Then wipe off moisture completely with a soft cloth.

2 Cleaning & Disinfection

⚠ CAUTION

- After wiping the parts with ethanol (70 vol% to 80 vol%), when you use them again, make sure that the disinfectant on the part surface is vaporized.

- ❗ Make sure that there is no visible moisture and contamination when wiping the parts.
- ❗ Be sure not to tug on the cable or cord when you clean the parts. This could cause the wire to break.
- ❗ Do not use disinfectants other than those designated by J. MORITA MFG. CORP.
- ❗ For details on handling disinfectants, refer to the accompanying user manual for each disinfectant.
- ❗ If too much disinfectant is applied to the piece of gauze or microfiber cloth, it will seep into the part and cause a malfunction.
- ❗ Do not immerse the parts in or wipe them with any of the following: functional water (acidic electrolyzed water, strong alkaline solution, and ozone water), medical agents (glutaral, etc.), or any other special types of water or commercial cleaning liquids. Such liquids may result in metal corrosion or adhesion of the residual medical agent to the parts.
- ❗ Do not clean or immerse the parts with chemicals such as formalin cresol (FC) and sodium hypochlorite. These will damage the metal and plastic parts. Immediately wipe away any chemicals that are accidentally spilled on the parts.

Disinfectants Approved by J. MORITA MFG. CORP.

Disinfectant	Country
Ethanol (70 vol% to 80 vol%)	U.S.A.
Opti-Cide3 (wipes)	
FD333 forte (wipes)	Other than U.S.A.

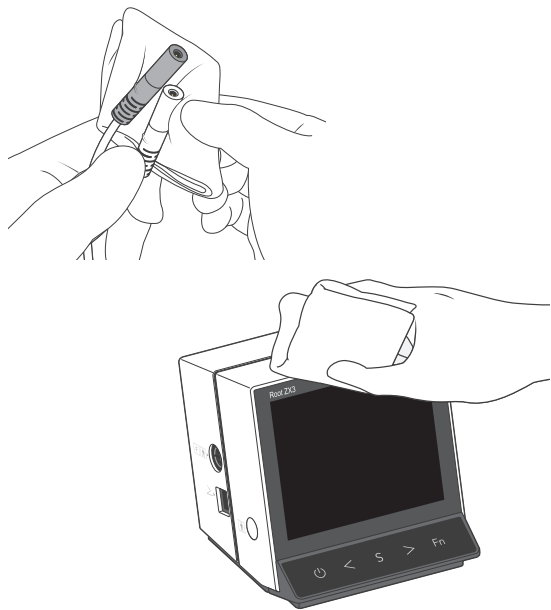

Wipe the part's surface with disinfectants approved by J. MORITA MFG. CORP.

7 How to Modify Various Settings

7.1 Memory Contents

7.1.1 Editable Items and Default Settings

CAUTION

- Always check the settings after changing the memory contents.

Editable Items

Item (displayed name)	Description
Flash Bar Position (FB.)	Indicates the position inside the root canal that provides a reference for the apex location and high-frequency conduction. This setting can be changed when the device is in M1 (EMR), M2 (LOW), M3 (MID), or M4 (HIGH).
High-Frequency Conduction Power (CUT.)	This can be set from CUT.1 to CUT.8. This setting can be changed when the device is in M5 (CUT.x).
Speaker Volume (VOL.)	Sound volume for switch operation and the indication of the HF file tip position inside the root canal. Speaker volume during the high-frequency conduction is fixed and it cannot be changed.

Default Settings

The default memory settings are listed below. These settings can be changed as needed.

Item (displayed name)	M1	M2	M3	M4	M5
Flash Bar Position (FB.)	32 (0.5 meter reading)				N/A* ¹
High-Frequency Conduction Power (CUT.)	N/A* ¹				5
Speaker Volume (VOL.)	2				

*¹ Items that you cannot set in the table above are indicated as "N/A".

7.1.2 Procedures for M1, M2, M3, and M4

1 Turn on the device.

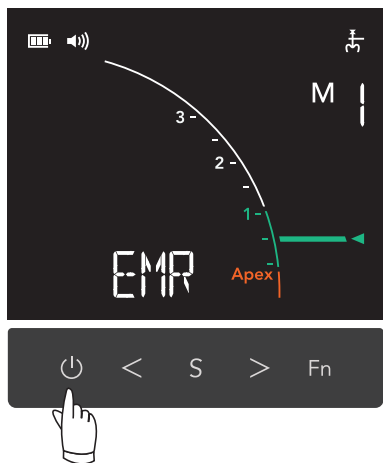

2 Select a memory number.

⚠ CAUTION

- Always check the settings of the selected memory before use.

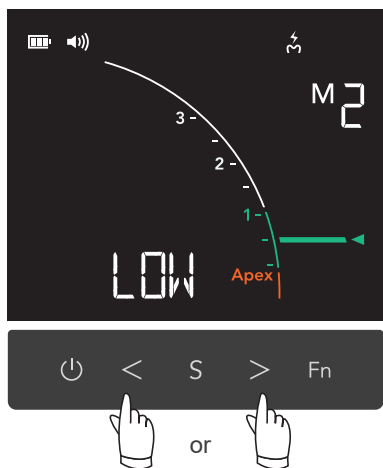

3 Select an editable item.



Hold down **S** more than 1 second to switch the display into flash bar position configuration screen.

Press **S** to switch the items.

FB. : Flash Bar Position

↕

VOL. : Speaker Volume

4 Change the settings.

● Flash Bar Position



The flash bar position can be set between meter gauge 2 (FB.20) and the Apex (FB.36).

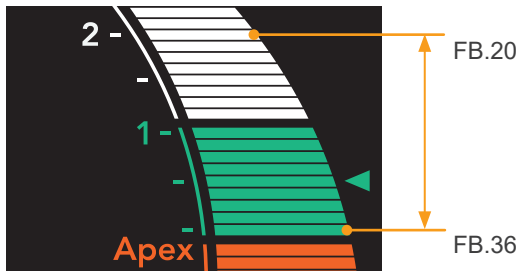

Meter Gauge Display and Flash Bar Display

Meter Gauge Display	Flash Bar Display Value
2	FB.20
1	FB.28
0.5 ◀	FB.32
Apex	FB.36

● Speaker Volume



VOL.0 🔇 VOL.1 🔊 VOL.2 🔊 VOL.3 🔊

5 Complete the configuration.

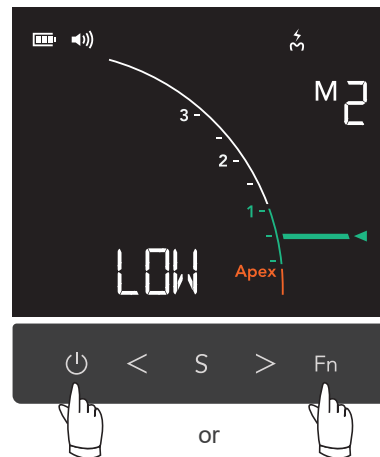

One of the following actions completes the change and the memory settings will be saved.

- Press **Fn**.
- Press **Power** to turn off the device.

* If any switches are not used for a defined period of time (standby screen return time), the device will save the changes.

7.1.3 Procedures for M5

1 Turn on the device.

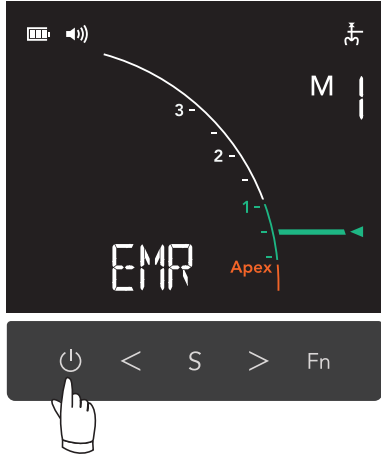

2 Select M5.

⚠ CAUTION
 • Always check the settings of the selected memory before use.



3 Select an editable item.



Hold down **S** for more than 1 second to switch the display to the high-frequency conduction power configuration screen.

Press **S** to switch the items.

CUT. : High-Frequency Conduction Power
 ⬆
 VOL. : Speaker Volume

4 Change the settings.

● High-Frequency Conduction Power



CUT.1 – CUT.8.

● Speaker Volume



VOL.0 VOL.1 VOL.2 VOL.3

5 Complete the configuration.



One of the following actions completes the change and the memory settings will be saved.

- Press **Fn**.
- Press **Power** to turn off the device.

* If any switches are not used for a defined period of time (standby screen return time), the device will save the changes.

7.2 Other Functions

Speaker tone, auto power off time, screen return time, and LCD brightness can be configured. These settings are common for all memories.

7.2.1 Editable Items and Default Settings

Item (displayed name)	Description	Default Settings
Speaker Tone (SPK.)	Select the tone for apex location. If there are multiple Root ZX3 units, you can set different tone for each unit.	SPK.1
Auto Power Off Time (AP.)	This sets the time it takes for the auto power off function to be triggered when no switches have been pressed.	AP.10
Screen Return Time (SR.)	This shows how long it takes for the device to exit the configuration screen if no switches have been pressed.	SR.10
LCD Brightness (LCD.)	The LCD display brightness can be changed.	LCD.2

7.2.2 Procedures

1 Turn on the device while holding down **S**.

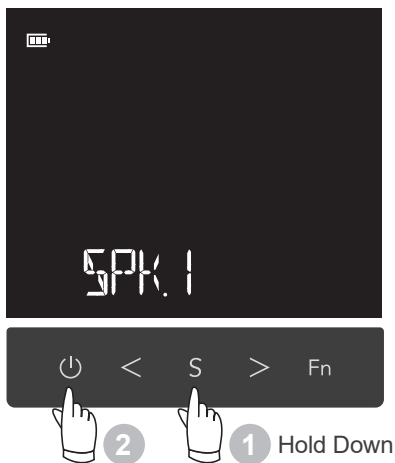

While the device power is off, hold down **S** and press **⏻**. The default setting “SPK.1” is displayed.

2 Select an editable item.

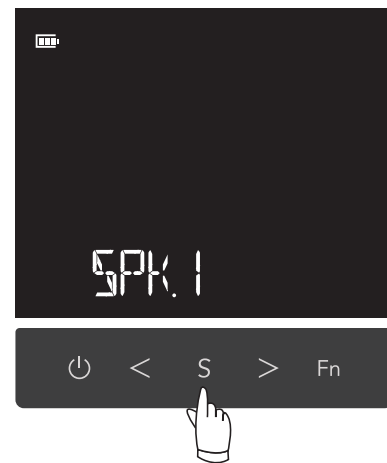

Press **S** to switch the items.

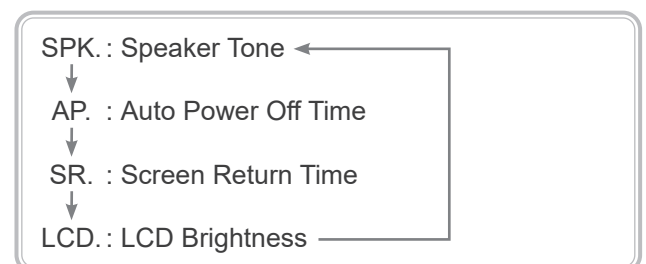

3 Change the settings.

● Speaker Tone

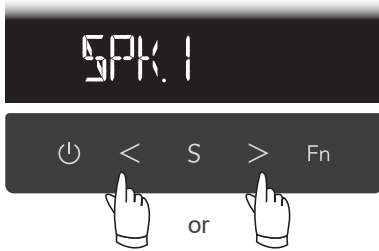

Select the tone for apex location.

SPK.1: A three-toned beep will sound.
SPK.2: A continuous short beep will sound.

● Auto Power Off Time

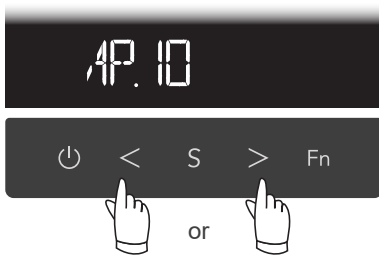

AP.03 – AP.15

● Screen Return Time



SR.03 – SR.15

● LCD Brightness



4 Complete the settings.

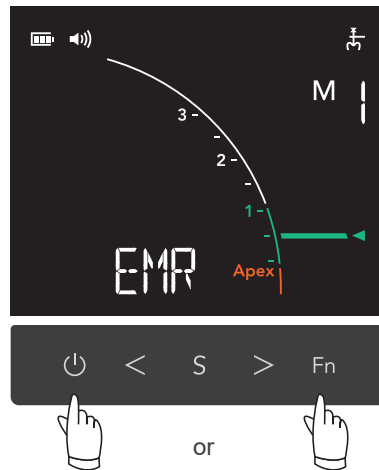

One of the following actions completes the change and the settings will be saved.

- Press **Fn**.
- Press **Power** to turn off the device.

* If any switches are not used for a defined period of time (auto power off time), the device will automatically turn it off and save the changes.



7.3 Resetting the Default Settings

All memories and other function settings will revert to their original default settings.

* This operation will affect all memories (M1, M2, M3, M4, M5) and other function settings. It is not possible to initialize just one of them.

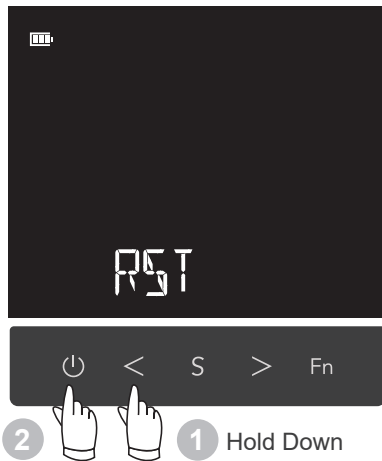
1 Turn on the device while holding down .





While the device power is off, hold down  and press .

“RST” is displayed.

2 Reset the memory settings.



Press . “” blinks and the initialization starts.

To cancel resetting the memory settings, press  and turn the device off.



After approximately 2 seconds, the memory settings will reset and “FIN” will be displayed. After resetting the memory settings, the standby screen is displayed.



8 Troubleshooting

8.1 Troubleshooting

If the Root ZX3 does not seem to be working properly, the user should first try to inspect and adjust it themselves.

* If you cannot inspect the device yourself or if the device fails to work properly after being adjusted or after parts are replaced, contact your local dealer or J. MORITA OFFICE.

Symptoms	Check Points	Possible Cause / Remedies	Ref. Page
Cannot turn on the device.	Is the battery pack installed properly?	Check the battery pack installation.	p. 63
	Is the battery power level low?	Charge the battery pack.	p. 40
	Is the battery pack degraded?	Replace the battery pack with a new one.	p. 63
Display does not appear.	Is there a sound when the unit is turned on and off?	If there is no sound, charge the battery pack. If there is a sound, the LCD display may be broken.	p. 40
No sound from the speaker.	Is the speaker volume set for "VOL. 0"?	Set it for "VOL. 1", "VOL. 2", or "VOL. 3".	p. 52
Cannot switch the memory number. Cannot change the memory settings.	Is apex location being performed?	You cannot operate anything other than the power switch during apex location.	p. 29
	Is high-frequency conduction being performed?	You cannot change settings or values during high-frequency conduction.	
	Does any switch work?	If it does not, it may be broken. Have the device professionally repaired.	N/A
Cannot perform apex location.	Is the contrary electrode properly hooked in the corner of the patient's mouth?	Hook the contrary electrode in the corner of the patient's mouth.	p. 27
	Are all connections properly plugged in?	Make sure all connections are plugged in all the way.	p. 18
	Is a wire in the HF probe cord broken?	Touch the HF tip holder or HF file holder's contact with wide contrary electrode to check if all the apex location indicator bars light up.	p. 21
	Is M5 (CUT.x) selected?	Apex location cannot be made in M5 (CUT.x). Select another memory number.	p. 30
The display of the apex location indicator bars is unstable.	Does the wide contrary electrode properly touch the patient's oral mucosa?	Adjust the wide contrary electrode position to touch the patient's oral mucosa properly so that the display stabilizes.	p. 27
	Is the HF file holder dirty?	Wipe the HF file holder with ethanol (70 vol% to 80 vol%) and clean it off.	p. 45

Symptoms	Check Points	Possible Cause / Remedies	Ref. Page
<p>The display of the apex location indicator bars makes abnormal movements as follows.</p> <ul style="list-style-type: none"> • Too short • Inaccurate • Too sensitive 	Does blood overflow from the opening of the root canal, or does blood contact the crown?	This will result in electrical leakage and an accurate apex location cannot be made. Clean the inside and opening of the canal thoroughly to get rid of all blood.	 *1
	Is the root canal filled with blood or chemical solution?	The meter suddenly will light up all the way when the file contacts with blood or chemical solution. In this case, advancing the HF file down the root canal will resume the meter display in the correct position and the apex location can be obtained properly.	
	Does cutting debris or chemical solution remain on the tooth?	Thoroughly remove all cutting debris or chemical solutions from the tooth.	
	Is the HF file touching the gums?	This will result in electrical leakage and the apex location indicator bars light up all the way. Do not touch the gums with the HF file.	
	Does pulp remain inside the canal?	If significant pulp remains inside the canal, an accurate apex location may not be obtained.	
	Is the HF file touching a metal prosthesis?	This will result in electrical leakage and the apex location indicator bars light up all the way. Do not touch the metal prosthesis with the HF file.	
	Is there a caries?	Electrical leakage through the caries infected area to the gums will make it impossible to obtain an accurate apex location.	
	Is there a branch or root fracture?	Branch's opening or root fracture could result in electrical leakage to the periodontal membrane and display the apex.	
	Is a large part of the crown broken resulting in electrical leakage to the gums? Is there a periapical lesion?	If there is a periapical lesion, physiological tissue is absorbed and accurate apex location may not be obtained. Build up the tooth with a suitable material to avoid electrical leakage to the gums.	
Is the HF file holder broken?	Replace it with a new one.	p. 28	
Is the HF file holder dirty?	Clean the HF file holder.	p. 45	
<p>The meter of the apex location indicator bars does not move.</p> <p>(It moves only near the apex.)</p>	Is it a blocked canal?	Open the canal all the way (patency) to the apical constriction.	 *1
	Is the apical foramen open?	If the apical foramen is open or a tooth's apex is immature, the meter may make a sudden and large movement near the apex.	
	Is the canal extremely dry?	In this case, try moistening inside the canal with oxydol or saline.	

*1 Refer to the apex locator module's user manual.

Symptoms	Check Points	Possible Cause / Remedies	Ref. Page
Cannot process in each mode. Feel high-frequency conduction is weak.	Is the wide contrary electrode approved by J. MORITA connected with the HF probe cord?	Connect the wide contrary electrode approved by J. MORITA with the HF probe cord.	p. 19
	Are the parts (the HF file holder or HF tip holder, HF relay cord, grip, and wide contrary electrode) connected to the probe connector properly?	Make sure that all parts are properly connected to the probe connector.	p. 18
	Is a wire in the HF probe cord broken?	Touch the wide contrary electrode with the HF file holder contact or the HF tip holder. If the meter does not move, the HF probe cord may be broken.	p. 21
	Is there any debris or coagulation on the tip of the HF file?	Remove it from the HF file.	p. 33
	Is the HF file holder or HF tip holder broken?	Use a new HF file holder or HF tip holder.	p. 28
The charge LED keeps blinking.	Are you recharging a fully charged battery pack?	The charge LED may blink when recharging immediately after charging is complete. Check the battery power on the LCD display. If the indicator gets three bars, keep using the battery pack.	p. 40
	Is the battery pack being charged in a high or low temperature environment?	Charge the battery pack at an ambient temperature between +10°C and +35°C (+50°F and +95°F).	p. 41
	Are you using a battery pack that has not been used for a long time?	If the charge LED keeps blinking for about 10 minutes, replace the battery pack with a new one.	p. 63
Feel battery loses power too quickly.	Are you recharging the battery pack every time after use?	Keep using until the indicator shows only one bar, then recharge the battery pack. Try this charging cycle two or three times. If the problem remains, replace the battery pack with a new one.	p. 63

8.2 Error Numbers

If an error or problem is detected, the Root ZX3 will stop working, an error number will appear in the LCD display, and an alarm will sound.

Turn the device off and then back on again. If the error message appears again, stop using the device immediately and contact your local dealer or J. MORITA OFFICE.

Make a note of the error number as well as the device serial number and report it when requesting support.

● M2 (LOW), M3 (MID), M4 (HIGH), M5 (CUT.x)

Error No.	Problems
ERR.A	High-frequency conduction error 1
ERR.B	High-frequency conduction error 2
ERR.C	HF module's memory error
ERR.D	Communication error between the modules
ERR.E	Battery pack power error
ERR.F	Charging error
ERR.G	Battery pack degradation error

E.g., ERR.A screen display

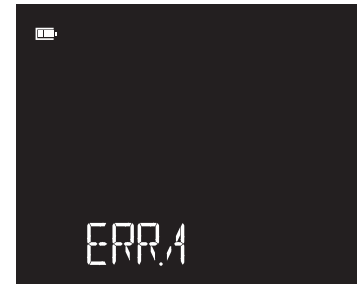

● M1 (EMR)

Error No.	Problems
ERR.0	Apex location error
ERR.1	Apex locator module's memory error
ERR.2	Speaker malfunction
ERR.3	Communication error between the modules
ERR.5	Battery power (voltage) error

E.g., ERR. 0 screen display

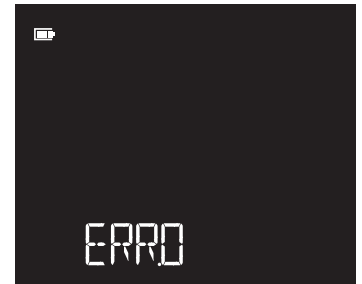

9 Replacement Parts

9.1 Parts Replacement







* Replace the parts as necessary depending on degree of wear and length of use.

* Order parts from your local dealer or J. MORITA OFFICE.

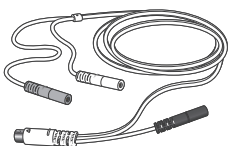





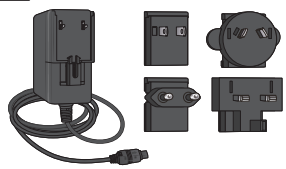



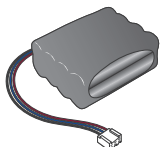





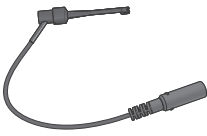

* For instructions on how to replace the battery pack;

 p. 63 "9.1.1 Battery Pack Replacement"

■ Replacement Parts

HF Probe Cord	HF Relay Cord	Foot Switch	AC Adapter
 Code No.: 4000795 	 Code No.: 4000796 	 Code No.: 4000797 	 Code No.: 4003777 

■ Consumables

Battery Pack (nickel-metal hydride rechargeable battery)  Code No.: 4000799 	Grip  Code No.: 4000800 	Wide Contrary Electrode  Code No.: 4000802 	HF File Holder  Code No.: 4000803 
HF Files K#10L25  Code No.: 4000804 	HF Files K#25L25  Code No.: 4000805 	HF Tip Holder  Code No.: 4000807 	HF Endo Tips K#10  Code No.: 4000808 
HF Endo Tips K#25  Code No.: 4000809 	HF Cutting Tips No.1  Code No.: 4000811 		

9.1.1 Battery Pack Replacement

CAUTION

- Do not leave the power on when disconnecting the battery.
- Use only the battery pack designed for this device. Other batteries could cause overheating.
- Do not use a battery if it is leaky, deformed, discolored or if its label is peeled off. It might overheat.

- ! Dispose of old battery packs (nickel-metal hydride rechargeable battery) in an environmentally safe way and in strict accordance with local regulations.

Replace the battery pack with a new one if it seems to be running out of power sooner than it should.

The battery will last for approximately 1 year under normal circumstances and use. (This depends somewhat on how the instrument is used and ambient conditions such as humidity.)

* To order a battery pack for this device, contact your local dealer or J. MORITA OFFICE.

When  is pressed, the Root ZX3 automatically checks its battery degradation. If the device detects battery degradation, "CHANGE BATTERY" will be displayed in the message indicator and a two-toned beep will sound five times. Replace the battery pack with a new one immediately.

If "ERR.G" is displayed in the message indicator after pressing , the battery pack is severely degraded and the device cannot be used.

1 Turn off the device.

 p. 32 "8 Turn off the device."

2 Remove the battery cover.

- ! Pay attention not to pull the rubber cover too hard. It might come off from the battery cover.
- ! Do not remove the battery cover if your hand or the HF module is wet.

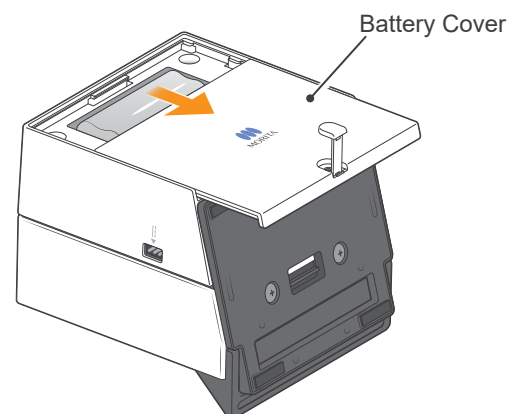
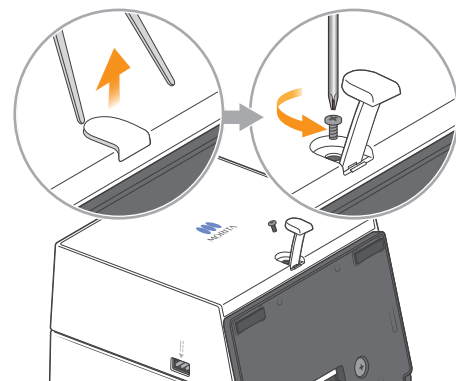

3 Remove the old battery pack.

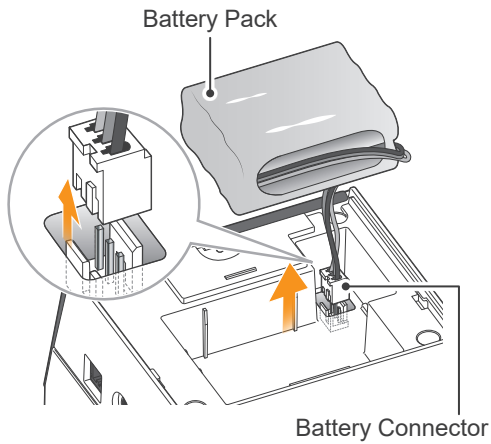

Remove the old battery pack.
Disconnect the battery connector.

4 Install a new battery pack.

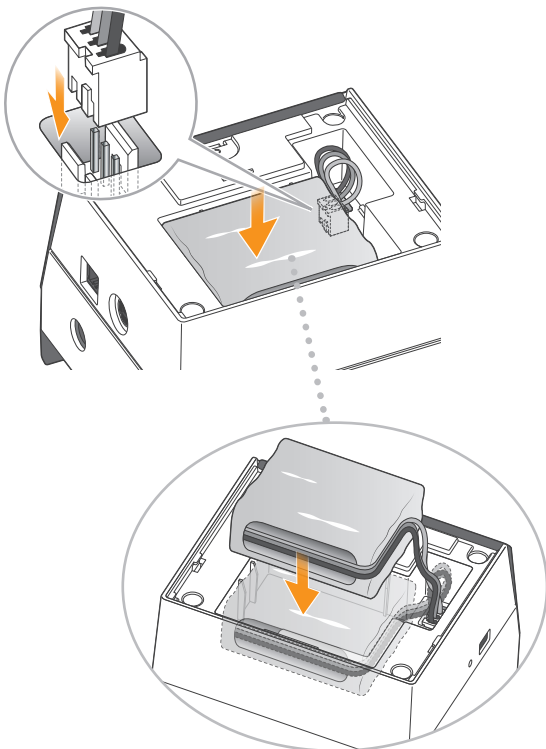

Connect the new battery pack's battery connector all the way in. Route the battery cord along the side of the battery pack, and place the battery pack in.

5 Reinstall the battery cover.

! Be careful not to pinch the battery cord when reinstalling the cover.

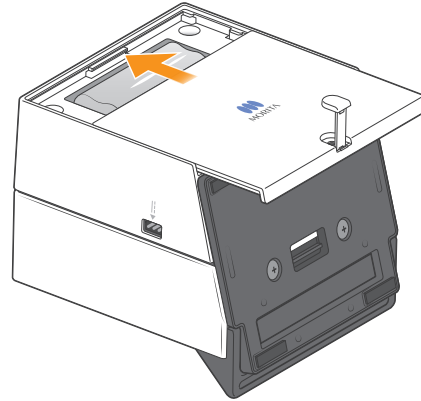

Place the battery cover back on the HF module.

6 Secure the battery cover.

! Do not tighten the screw too much. This could strip the threads.

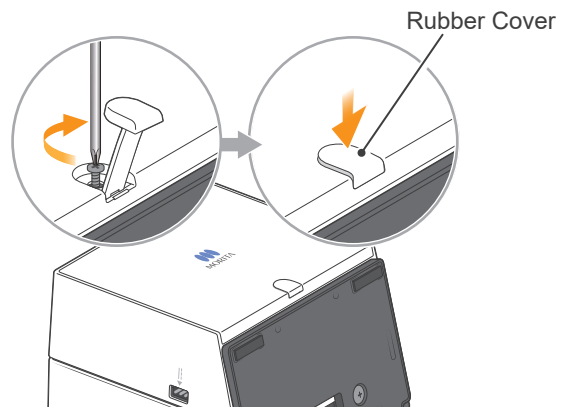

Tighten the screw and fix the battery cover.
Place the rubber over back.

10 Electromagnetic Disturbances (EMD)

The Root ZX3 (Model: RZX3, hereafter “this device”) conforms to IEC 60601-1-2 Edition 4.0, the relevant international standard for electromagnetic disturbances (EMD).

Use Environment

The use environment of this device is the PROFESSIONAL HEALTHCARE FACILITY ENVIRONMENT.

WARNING

- Use of this device adjacent to or stacked with other equipment should be avoided because it could result in improper operation. If such use is necessary, this device and the other equipment should be observed to verify that they are operating normally.
- Use of accessories, transducers and cables other than those specified or provided by us could result in increased electromagnetic emissions or decreased electromagnetic immunity of this device and result in improper operation.
- Portable RF communications equipment (including peripherals such as antenna cables and external antennas) should be used no closer than 30 cm (12 inches) to any part of the RZX3, including cables specified by the manufacturer. Otherwise, degradation of the performance of this device could result.

Cable List

No.	Name	Cable Length, Shielding	SIP/SOP & In/Out Port Type
1	DC Power Cable	2.1 m, Un-shielded	DC Power Port
2	Foot Switch Cable	2.0 m, Un-shielded	Signal Input/Output Port
3	HF Probe Cord	2.15 m, Un-shielded	PATIENT-Coupled Cable

Compliance for Each EMISSIONS and IMMUNITY Standards

Emissions Test	Compliance	Electromagnetic Environment – Guidance
RF emissions CISPR 11	Group 1 Class B	This device is suitable for use in all establishments, including domestic establishments and those directly connected to the public low-voltage power supply network that supplies buildings used for domestic purposes.
RF emissions CISPR 11	Group 1 Class B	
Harmonic emissions IEC 61000-3-2* ¹	N/A	
Voltage fluctuations/flicker emissions IEC 61000-3-3* ¹	Clause 5	

*¹ Although this device is not applicable to Harmonics test since the rated power is less than 75 W, it has been tested as a reference according to limits for Class A.

Immunity Test	IEC 60601 Test Level	Compliance Level	Electromagnetic Environment – Guidance
Electrostatic discharge (ESD) IEC 61000-4-2	<u>Contact</u> ±8 kV <u>Air</u> ±2 kV, ±4 kV, ±8 kV, ±15 kV	<u>Contact</u> ±8 kV <u>Air</u> ±2 kV, ±4 kV, ±8 kV, ±15 kV	Floors should be wood, concrete or ceramic tile. If floors are covered with synthetic material, the relative humidity should be at least 30%.
Electrical fast transients/bursts IEC 61000-4-4	<u>Power Supply Lines</u> ±2 kV <u>Input/Output Lines</u> ±1 kV	<u>Power Supply Lines</u> ±2 kV <u>Input/Output Lines</u> * ² ±1 kV	Mains power quality should be that of a typical commercial or hospital environment.
Surge IEC 61000-4-5	<u>Input Power Ports</u> ±0.5 kV, ±1 kV line(s) to line(s) ±0.5 kV, ±1 kV, ±2 kV line(s) to earth <u>Signal Input/Output</u> ±2 kV line(s) to earth	<u>Input Power Ports</u> ±0.5 kV, ±1 kV line(s) to line(s) ±0.5 kV, ±1 kV, ±2 kV line(s) to earth <u>Signal Input/Output</u> * ³ ±2 kV line(s) to earth	Mains power quality should be that of a typical commercial or hospital environment.
Voltage dips, short interruptions, and voltage variations on power supply lines IEC 61000-4-11	<u>Dips</u> 0% U_T : 0.5 cycles (at 0, 45, 90, 135, 180, 225, 270, 315°) 0% U_T : 1 cycle (at 0°) 70% U_T : 25/30 cycle (at 0°) 25 (50 Hz)/30 (60 Hz) <u>Short Interruptions</u> 0% U_T : 250/300 cycle 250 (50 Hz)/300 (60 Hz)	<u>Dips</u> 0% U_T : 0.5 cycles (at 0, 45, 90, 135, 180, 225, 270, 315°) 0% U_T : 1 cycle (at 0°) 70% U_T : 25/30 cycle (at 0°) 25 (50 Hz)/30 (60 Hz) <u>Short Interruptions</u> 0% U_T : 250/300 cycle 250 (50 Hz)/300 (60 Hz)	Mains power quality should be that of a typical commercial or hospital environment. If the user of this device requires continued operation during power mains interruptions, it is recommended that this device be powered from an uninterruptible power supply or a battery.
Power frequency (50/60 Hz) magnetic field IEC 61000-4-8	30 A/m (r.m.s) Select from 50 Hz, 60 Hz as required	30 A/m (r.m.s) 50 Hz and 60 Hz	Power frequency magnetic field should be at levels characteristic of a typical location in a typical commercial or hospital environment.
NOTE 1: U_T is the a.c. mains voltage prior to application of the test level. NOTE 2: r.m.s (root mean square)			

*² This test is not applicable since the EUT signal cable is less than 3 m.

*³ Not applicable because it does not connect directly to outdoor cable.

Immunity Test	IEC 60601 Test Level	Compliance Level	Electromagnetic Environment – Guidance
Conducted RF IEC 61000-4-6	3 V 0.15 MHz to 80 MHz 6 V ISM ^(c) bands between 0.15 MHz to 80 MHz	3 V 0.15 MHz to 80 MHz 6V ISM ^(c) bands between 0.15 MHz to 80 MHz	<p>Portable and mobile RF communications equipment should be used no closer to any part of this device, including cables, than the recommended separation distance calculated from the equation applicable to the frequency of the transmitter.</p> <p>Recommended Separation Distance: $d = \frac{6}{E} \sqrt{P}$ </p> <p>Where P is the maximum output power rating of the transmitter in watts (W) according to the transmitter manufacturer, E is the compliance level in V/m and d is the recommended separation distance in meters (m).</p> <p>Field strengths from field RF transmitters, as determined by an electromagnetic site survey^(a), should be less than the compliance level in each frequency range^(b).</p> <p>Interference may occur in the vicinity of equipment marked with the following symbol:</p> 
Radiated RF IEC 61000-4-3	3 V/m 80 MHz to 2.7 GHz	3 V/m 80 MHz to 2.7 GHz	
	27 V/m 385 MHz	27 V/m 385 MHz	
	28 V/m 450 MHz	28 V/m 450 MHz	
	9 V/m 710, 745, 780 MHz	9 V/m 710, 745, 780 MHz	
	28 V/m 810, 870, 930 MHz	28 V/m 810, 870, 930 MHz	
	28 V/m 1720, 1845, 1970 MHz	28 V/m 1720, 1845, 1970 MHz	
	28 V/m 2450 MHz	28 V/m 2450 MHz	
	9 V/m 5240, 5500, 5785 MHz	9 V/m 5240, 5500, 5785 MHz	

NOTE: These guidelines may not apply in all situations. Electromagnetic propagation is affected by absorption and reflection from structures, objects and people.

^(a) Field strengths from fixed transmitters, such as base stations for radio (cellular/cordless) telephones and land mobile radios, amateur radio, AM and FM radio broadcast and TV broadcast cannot be predicted theoretically with accuracy. To assess the electromagnetic environment due to fixed RF transmitters, an electromagnetic site survey should be considered. If the measured field strength in the location in which this device is used exceeds the applicable RF compliance level above, this device should be observed to verify normal operation. If abnormal performance is observed, additional measures may be necessary, such as reorienting or relocating this device.

^(b) Over the frequency range 0.15 kHz to 80 MHz, field strengths should be less than 3 V/m.

^(c) The ISM (Industrial, Scientific and Medical) bands between 0.15 MHz and 80 MHz are 6.765 MHz to 6.795 MHz; 13.553 MHz to 13.567 MHz; 26.957 MHz to 27.283 MHz; and 40.66 MHz to 40.70 MHz.

11 Technical Specifications

11.1 Specifications

* Specifications may be changed without notice due to improvements.

Name	Root ZX3
Model	RZX3
Type	HF
Operating Principle	<p>The Apex Locator module has the apex locating function achieved by measuring the electrical impedance between the active electrode and the neutral electrode, which makes it possible to measure the root canal length. Apex position is detected and the root canal length and working length can be determined with reference to this apex position.</p> <p>By connecting the HF module to the Apex Locator module, electro-surgical function is added. The principle of an electrosurgical module is common to the existing electrosurgical devices and the principle is well established. Root ZX3 is used for the oral cavity and root canal and conducts high frequency current to the patient through the active electrode and it returns to the device through a separate patient-connected neutral electrode. The effects occurs at the area in contact with the active electrode, tissue near the electrode and stricture area of root canal where the current flows. The heat generated in the contact resistance between active electrode and tissues or resistance of stricture area of root canal achieves the intended effect.</p> <p>Principle of each effect and relationship to the procedure is as follows:</p> <p>Incision: The heat dissolve and vaporize cells, and separate/cut the tissue. Cutting around the intended area achieves excision. Gingivoplasty (shaping the gums), gingivectomy (removing part of the gums or gum retraction) and excision of intraoral lesions are achieved by incising or excising the intended area.</p> <p>Hemostasis: Hemostasis is achieved by coagulation of blood or tissue. Coagulation is protein denaturation with heat caused by high frequency current.</p> <p>Cauterization with heat caused by high frequency current achieves ablation of pulp, ablation of dental filling material (e.g. gutta-percha) and tissue in / around root canals. High frequency current concentrates on parts in contact with the active electrode and tissue near the electrode, heating the load resistance and cauterizing tissues and substances.</p>
Essential Performance	None (There is no unacceptable risk.)
Protection against Harmful Ingress of Water or Particulate Matter	IPX0 IPX1 (foot switch)
Protection against Electric Shock	Internal power supply device / Type BF applied part
Oscillation Frequency	533 ±10 kHz
Applied Parts	HF file holder, HF tip holder, HF file, HF Endo tip, HF Cutting Tip, Wide contrary electrode, Grip
Rated Input Voltage	DC 9.6 V (nickel-metal hydride rechargeable battery)
Maximum Output	45 W
Outer Dimensions	Approx. Height: 90 mm, Width: 95 mm, Length: 105 mm
Weight	Approx. 360 g

Output	Memory No.		Maximum Output Voltage [V]	Maximum Output Current [mA]	Load Resistance [Ω]	Output [W]
	M2		550	158	500	12.5
	M3		550	158	500	12.5
	M4		550	158	500	12.5
	M5	CUT.8	550	196	600	23.2
CUT.4		380	180	700	22.3	

AC Adapter	
Input	AC 100 V to 240 V, 50 Hz to 60 Hz
Output	DC 15 V
Protection against Electric Shock	Class II





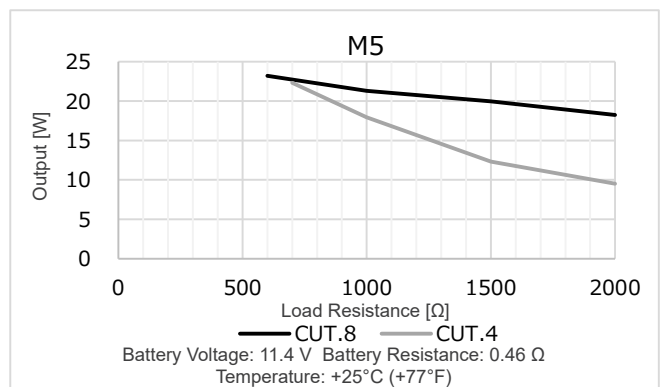
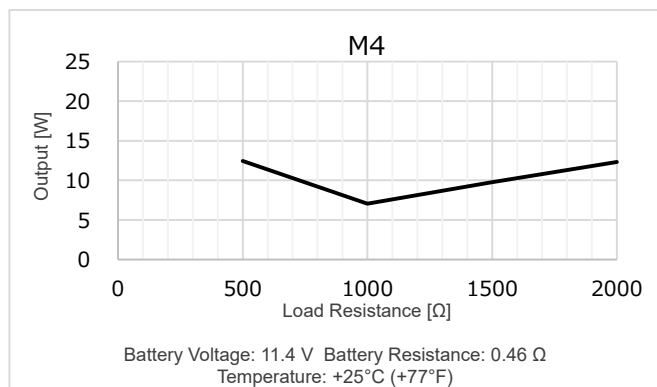
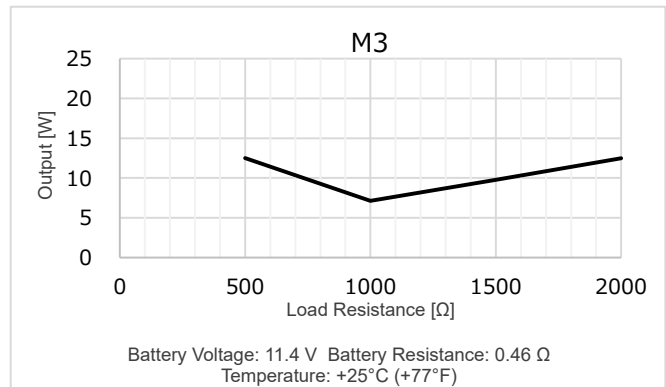
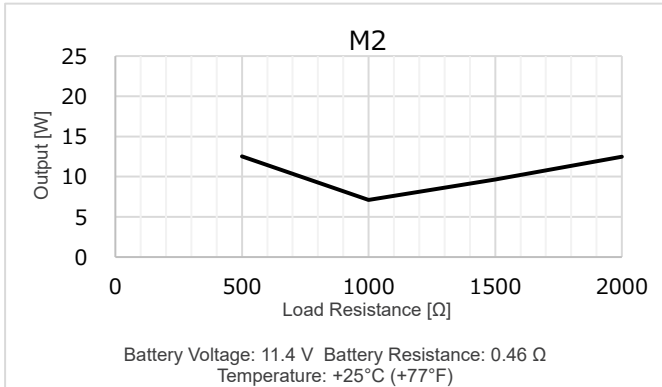























* The Root ZX3 conducts high-frequency electromagnetic waves during use. Sufficient consideration is required for installation and use.

11.2 Output Characteristic Curve



11.3 Symbols

* Some symbols may not be used.

	Manufacturer		Date of manufacture
	Serial number		Unique device identifier
	Medical device		Lot Number
	GS1 DataMatrix		Direct current
	Type BF applied part		Autoclavable up to 135°C (+275°F)
	Supports washer-disinfectors		Refer to instructions for use
	Fragile		Keep away from rain
	Temperature limitation		This way up
	Atmospheric pressure limitation		Humidity limitation
	CE (0197) marking Conforms with the European Regulation, EU 2017/745 CE marking Conforms with the European Directive, EU 2011/65		Marking of electrical Equipment in accordance with the European Directive, EU 2012/19 (WEEE)
	EU Authorized Representative under the European Regulation, EU 2017/745		Non-Sterile Sterilize components before use
	Prescription Device CAUTION: Federal law restricts this device to sale by or on the order of a dentist. (Valid only for U.S.A.)		Packaging unit
	Importer		Distributor
	Consult instructions for use or electronic instructions for use		Model number

12 Regular Inspection

12.1 Regular Inspection

* Regular inspection is generally considered to be the duty and obligation of the user, but, if, for some reason, the user is unable to carry out this duty, this may be performed by the accredited service personnel. Contact your local dealer or J. MORITA OFFICE for details.

* The Root ZX3 should be inspected every 6 months in accordance with the following regular inspection items.

* For repair or other types of service, contact your local dealer or J. MORITA OFFICE.

* J. MORITA MFG. CORP. will offer replacement parts and service for the product for a period of 10 years after the manufacturing of the product has been discontinued. Replacement parts and service will continue to be available during that period.

12.1.1 Regular Inspection Items

Inspection Item		Check Point
1	• AC Adapter • Battery Pack	• Insert the AC adapter's plug into the HF module, and then plug the AC adapter into the power outlet. Check that the charge LED located over the connection port blinks.
		• Check that you do not feel the battery pack is losing power too quickly when it is fully charged.
2	• Switches	• Check that the device turns on when the power switch is pressed, and that the unit turns off when the power switch is pressed again.
		• Check that the memory number (M1, M2, M3, M4, M5) is changed when the forward or reverse switch is pressed.
		• Check the settings for each of the memories can be changed when the select or function switch is pressed.
3	• HF Probe Cord • HF Relay Cord • Foot Switch	• Visually inspect the parts and make sure that they are not damaged or dirty.
		• Check that the HF relay cord's connector goes into the HF probe cord's connector properly.
		• Check that the foot switch's connector goes into the HF module's connection port properly.
		• Check that the HF probe cord's plug goes into the HF module's connection port properly.

Inspection Item		Check Point
4	<ul style="list-style-type: none"> • HF File • HF Endo Tip • HF Cutting Tip • HF File Holder • HF Tip Holder • Wide Contrary Electrode • Grip 	<ul style="list-style-type: none"> • Check if there is any debris on the active electrodes.
		<ul style="list-style-type: none"> • Visually inspect the parts and make sure that they are not dirty, bent, damaged, or worn out.
		<ul style="list-style-type: none"> • Check that the HF tip holder or HF file holder's plug goes into HF probe cord's connector (gray) properly.
		<ul style="list-style-type: none"> • Check that the HF file holder or HF tip holder's hook clips the active electrodes properly.
		<ul style="list-style-type: none"> • Check that the wide contrary electrode goes into the HF probe cord's connector (white).
		<ul style="list-style-type: none"> • Check that the grip's connector goes into the HF relay cord's connector (black).
5	<ul style="list-style-type: none"> • Apex Location Indicator Bar 	<ul style="list-style-type: none"> • Touch the wide contrary electrode with the HF file holder's contact or HF tip holder's active electrode and check the following points. <ul style="list-style-type: none"> • All the apex location indicator bars are lit up. • "OVER", "Apex", and "◀" (0.5 meter reading) blink. • A short two-toned beep sounds.

13 Service and Disposal

13.1 Service

For repair or other types of service, contact your local dealer or J. MORITA OFFICE.

The Root ZX3 may be repaired and serviced by:

- The technicians of J. MORITA's subsidiaries all over the world.
- Technicians employed by authorized J. MORITA dealers and specially trained by J. MORITA.
- Independent technicians specially trained and authorized by J. MORITA.

13.2 Standards and Procedures for Disposal of Medical Devices

The dentist or doctor responsible for the patient's treatment must confirm that a medical device is uncontaminated, and must then have it disposed of by a healthcare facility or an agent licensed and qualified to handle standard industrial waste and industrial waste requiring special treatment.



The battery should be recycled. Metal parts of the device are disposed of as scrap metal. Synthetic materials, electrical components, and printed circuit boards are disposed of as electrical scrap. Material must be disposed of according to the relevant national legal regulations. Consult specialized disposal companies for this purpose. Please inquire of the local administration concerning local disposal companies.



Development and Manufacturing

J. MORITA MFG. CORP.

680 Higashihama Minami-cho, Fushimi-ku, Kyoto 612-8533, Japan
T +81. (0)75. 611 2141, F +81. (0)75. 622 4595

Morita Global Website

www.morita.com

Distribution

J. MORITA CORP.

3-33-18 Tarumi-cho, Suita-shi, Osaka 564-8650, Japan
T +81. (0)6. 6380 1521, F +81. (0)6. 6380 0585

J. MORITA USA, INC.

9 Mason, Irvine CA 92618, USA
T +1. 949. 581 9600, F +1. 949. 581 8811

J. MORITA EUROPE GMBH

Justus-von-Liebig-Strasse 27b, 63128 Dietzenbach, Germany
T +49. (0)6074. 836 0, F +49. (0)6074. 836 299

MORITA DENTAL ASIA PTE. LTD.

150 Kampong Ampat #06-01A KA Centre, Singapore 368324
T +65. 6779. 4795, F +65. 6777. 2279

J. MORITA CORP. AUSTRALIA & NEW ZEALAND

Suite 2.05, 247 Coward Street, Mascot NSW 2020, Australia
T +61. (0)2. 9667 3555, F +61. (0)2. 9667 3577

J. MORITA CORP. MIDDLE EAST

4 Tag Al Roasaa, Apartment 902, Saba Pacha 21311 Alexandria, Egypt
T +20. (0)3. 58 222 94, F +20. (0)3. 58 222 96

J. MORITA CORP. INDIA

Filix Office No.908, L.B.S. Marg, Opp. Asian Paints, Bhandup (West), Mumbai 400078, India
T +91-82-8666-7482

J. MORITA MFG. CORP. INDONESIA

28F, DBS Bank Tower, Jl. Prof. Dr. Satrio Kav. 3-5, Jakarta 12940, Indonesia
T +62-21-2988-8332, F + 62-21-2988-8201

SIAMDENT CO., LTD.

71/10 Moo 5 T. Tharkham A. Bangpakong Chachuengsao 24130 Thailand
T +66 (0) 3857 3042, F +66 (0) 3857 3043
www.siamdent.com

Diagnostic and Imaging Equipment



Treatment Units



Handpieces and Instruments



Endodontic Systems



Laser Equipment



Laboratory Devices



Educational and Training Systems



Auxiliaries

