

Apex Locator

Root ZX mini

INSTRUCTIONS FOR USE

CE
0197



Table of Contents

Prevent Accidents	4
Warnings and Prohibitions	6
Parts Identification and Accessories	7
Usage	8
1. Before Using the Unit.....	8
Installing the Batteries.....	8
Connecting the Probe Cord.....	9
Checking the Function.....	9
2. Operating the Unit.....	11
Operation Panel Display and Switches.....	11
Settings.....	12
Meter Display.....	14
Root Canals Not Suitable for Electric Apex Location.....	17
Root ZX mini Meter Reading and Radiography.....	19
3. After Using the Unit.....	20
4. Replacing Batteries.....	21
Reprocessing	23
1. Parts to be Sterilized.....	24
Pre-treatment	24
Cleaning & Disinfection.....	25
Packing.....	26
Sterilization.....	27
2. Parts to be Disinfected.....	28
Pre-treatment	28
Cleaning & Disinfection.....	29

Replacement Parts, Transport and Storage	30
Replacement Parts.....	30
Transport and Storage Environments.....	30
Inspection	31
Maintenance and Inspection Items.....	31
Troubleshooting	33
Technical Specifications	35
Specifications.....	35
Symbols.....	36
Electromagnetic Disturbances (EMD)	37

Thank you for purchasing the Root ZX mini.

For optimum safety and performance, read this manual thoroughly before using the unit and pay close attention to warnings and notes. Keep this manual in a readily accessible place for quick and easy reference.

Trademarks (™) and Registered Trademarks (®):

The names of companies, products, services, etc. used in this manual are either trademarks or registered trademarks owned by each company.

Prevent Accidents

Attention Customers

Do not fail to receive clear instructions concerning the various ways to use this device as described in this accompanying Operation Instructions.

To access the warranty information for this product, scan the following QR code and visit our website.



Attention Dealers

Do not fail to give clear instructions concerning the various ways to use this device as described in this accompanying operator's manual.

Prevent Accidents

Most operation and maintenance problems result from insufficient attention being paid to basic safety precautions and not being able to foresee the possibilities of accidents. Problems and accidents are best avoided by foreseeing the possibility of danger and operating the device in accordance with the manufacturer's recommendations. First thoroughly read all precautions and instructions pertaining to safety and accident prevention; then, operate the device with the utmost caution to prevent either damaging the device itself or causing bodily injury.



The following symbols and expressions indicate the degree of danger and harm that could result from ignoring the instructions they accompany:

WARNING

This warns the user of the possibility of extremely serious injury or complete destruction of the device as well as other property damage including the possibility of fire.

CAUTION

This warns the user of the possibility of mild injury or damage to the device.

The warning symbols () and caution symbols () that appear next to the main text on the right hand side of the page refer to and are explained by the Warnings and Cautions at the bottom of the page.

(Mandatory Action)

This alerts the user of important points concerning operation or the risk of device damage.

The user (e.g., healthcare facility, clinic, hospital etc.) is responsible for the management, maintenance and use of medical device.

This device must only be used by dentists and other legally licensed professionals.
Do not use this device for anything other than its specified dental purpose.

The Useful Life

- The useful life of the Root ZX mini is 6 years from the date of shipment provided it is regularly and properly inspected and maintained.

In Case of Accident

If an accident occurs, the Root ZX mini must not be used until repairs have been completed by a qualified and trained technician authorized by the manufacturer.

Intended Operator Profile

This device must only be used by dentists and other legally licensed professionals.

Patient Population

Age	Child to Elderly
Weight	N/A
Nationality	N/A
Sex	N/A
Health	It is not intended for use on patients wearing pacemakers or ICDs.
Condition	Conscious and mentally alert person. (Person who can stay still during treatment.)



CAUTION

- This device is not recommended for use in children under 12 years of age.

Warnings and Prohibitions

* J. MORITA MFG. CORP. is not responsible for any accidents or other types of trouble that are caused by not following the warnings and prohibitions noted below.

WARNING

- Accurate apex location may not always be possible. It depends on tooth condition, case complexity, as well as degradation of the device.
- Do not use a damaged file holder. Otherwise, accurate apex location cannot be obtained.
- When a continuous tone is heard while the main power switch is on and without any operation, some electrical part may be malfunctioning. Do not use the unit and send the unit to J. MORITA OFFICE for repairing.
- A rubber dam should be used when performing endodontic treatment.
- Some care must be taken concerning electromagnetic compatibility (EMC) when using the Root ZX mini. Refer to the user's manual and other attached documents for EMC information regarding installation and operation.
- Both portable and movable radio frequency transmitters may have some effect on the Root ZX mini.
- Using replacement parts or accessories not supplied by the original manufacturer could adversely affect the EMC performance of the Root ZX mini.
- As far as possible, do not use the Root ZX mini near or simultaneously with other devices. If this cannot be avoided, observe carefully and make sure both the Root ZX mini and the other device operate normally.
- Always wear personal protective equipment (PPE) such as safety glasses, gloves, a mask, etc. when using and reprocessing the Root ZX mini.

PROHIBITION: This indicates when not to use the device.

- Do not use this device in conjunction with an electric scalpel or on patients who have a pacemaker.
- Accurate apex location cannot be obtained with blocked canals.
- Except for ways described in this manual, this device must not be connected to or used in combination with any other apparatus or system. It must not be used as an integral component of any other apparatus or system. J. MORITA MFG. CORP. will not be responsible for accidents, product damage, bodily injury or any other trouble which results from ignoring this prohibition.
- Illumination devices such as fluorescent lights and the Film viewer which use an inverter can cause the Root ZX mini to operate erratically. Do not use the Root ZX mini near devices such as these.
- Electromagnetic wave interference could cause this device to operate in an abnormal, random and possibly dangerous manner. Cellular phone, transceivers, remote controls and all other devices which transmit electromagnetic waves located inside the building should be turned off.
- Do not perform maintenance while using the Root ZX mini for treatment.

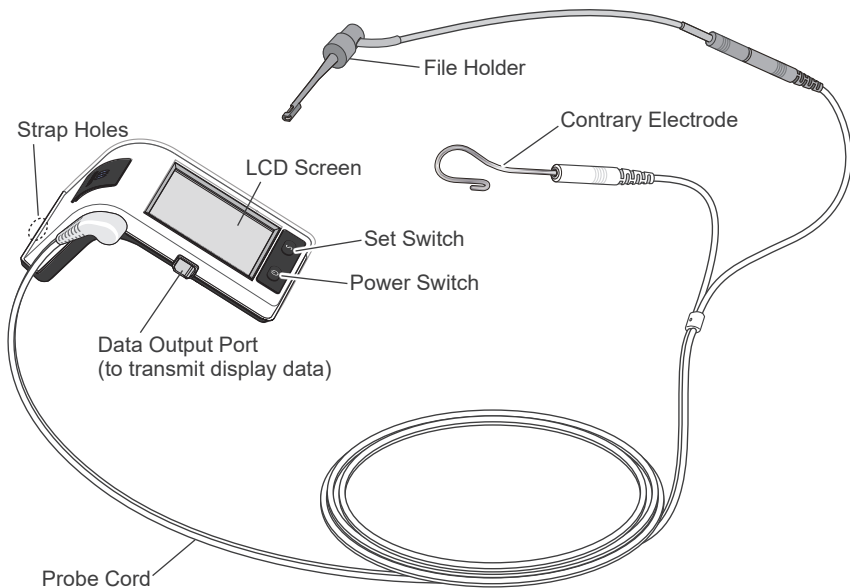

Parts Identification and Accessories

Parts Identification

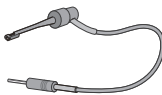
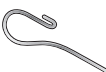

Accessories

Standard Accessories

Probe Cord (1)	File Holder (3)	Contrary Electrode (5)	Tester (1)	Alkaline Dry Cells (3) <small>(LR03 (AAA size) batteries)</small>
				

Optional Accessories

Long File Holder (1)

Usage

1. Before Using the Unit



! Be sure to perform reprocessing on the respective parts before using them for the first time.

Installing the Batteries

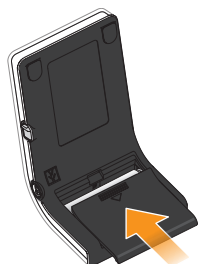
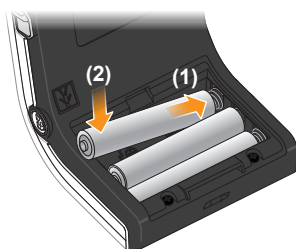
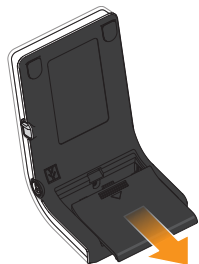

1. Slide the cover in the direction by the arrow in the illustration and remove it from the Root ZX mini.

2. Insert the 3 LR03 (AAA size) batteries included in the package.

(1) Insert the batteries by first pressing center of the minus end against its spring contact.

(2) Slide the plus end down into place and make sure the contacts are not bent or damaged.

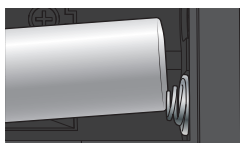

Incorrect

3. Slide the cover all the way down until it is securely closed.

! CAUTION

- The Root ZX mini is shipped without the batteries installed. Remove the cover and install the 3 LR03 (AAA size) batteries.
- Do not reverse the plus and minus poles.
- Never allow the spring contact to push against the edge of the battery. This could damage the outer cover causing a short or a leakage of battery liquid.
- After installation, give the cover a light tug to confirm it is securely attached.

Connecting the Probe Cord

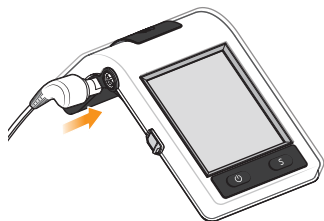

1. Insert the probe cord completely into the jack on the left side of the Root ZX mini.

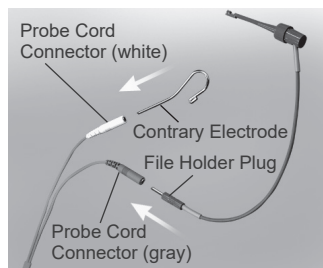

2. Insert the file holder's gray male plug into the gray female connector on the probe cord. Insert the contrary electrode into the white female connector on the probe cord.



Checking the Function



Power Switch

1. Press the Power switch to turn the unit on. The display will appear in the LCD screen.

* The device turns off by itself if it is not used for 10 minutes.

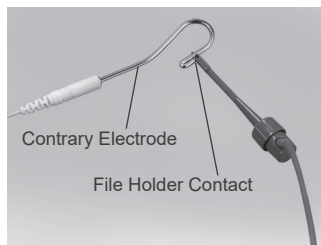

2. Check that the probe cord is properly plugged into the jack.
3. Check that the file holder and contrary electrode are properly connected to the probe cord.
4. Touch the metal part of the file holder with the contrary electrode. Check that all the meter indicator bars on the display light up.

CAUTION

- Handle the Root ZX mini carefully; do not drop, bump or expose the unit to other kinds of impacts or shocks. Rough handling could cause damage.
- Make sure the probe cord plug is securely plugged into the jack. A poor connection may prevent accurate apex location.
- Do not drop anything on or bang the probe cord plug after it has been inserted into the jack.
- Make sure to match colors of the file holder and contrary electrode to the probe cord. Accurate apex location cannot be obtained if these connections are reversed.
- The unit may turn off if its side is bumped.

Checking the Function

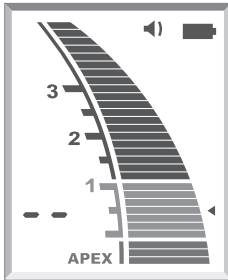

■ Checking the Function with the Tester

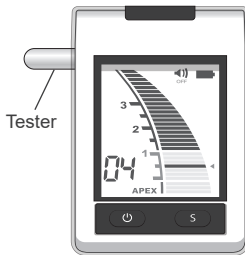

Check the Root ZX mini's performance with the tester once a week.

1. Press the Power switch to turn the unit on.
2. Insert the tester into the probe cord jack.
Check that the meter indicates within ± 3 bars away from (above or below) 1.

* The meter may jump when the tester is inserted. If it does, wait for about one second until the meter stabilizes and then check the reading.

* If the reading is 4 or more bars away from 1, an accurate apex location cannot be obtained. In this case, contact your local dealer or J. MORITA OFFICE.

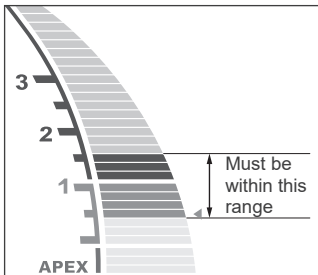

WARNING

- Check the Root ZX mini operation before each patient. If the indicators in the display do not all appear normally, an accurate apex location cannot be obtained. In this case, stop using the device and have it repaired.

2. Operating the Unit

Operating Environments

Temperature: +10°C to +35°C (+50°F to +95°F)

Humidity: 30% to 80% (without condensation)

Atmospheric Pressure: 70 kPa to 106 kPa

* If the unit has not been used for some time, make sure it works properly before using it again.



Operation Panel Display and Switches

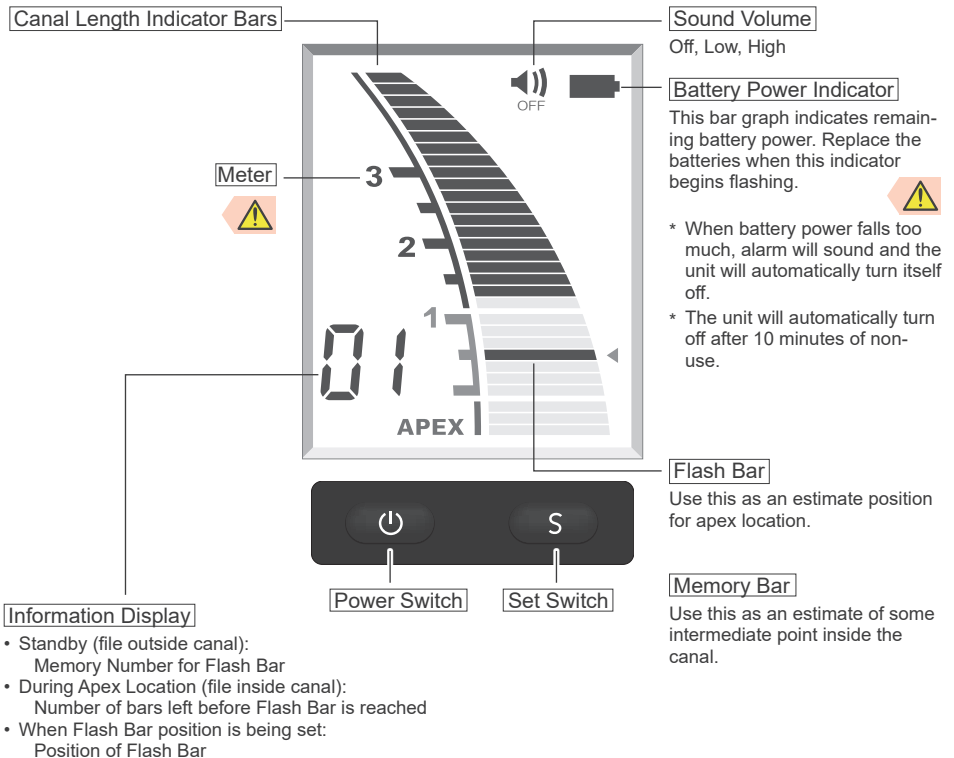

⚠ WARNING

- Never connect the Root ZX mini to any device not approved by J. MORITA MFG. CORP.
- Never use the unit if the battery power indicator is flashing on and off. The unit may not function properly if the battery power is low.
- The meter readings 1, 2, and 3 do not correspond to any actual distance and should only be used as estimates.

Settings

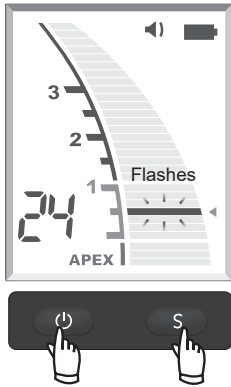

1. Select Memorized Flash Bar

Method

Press Set Switch. Each press of the Set Switch will change the memory selected in the sequence 01 to 02 to 03 and then back to 01 again. The Flash Bar set for each memory will appear when that memory is selected. The memory selected when the unit is turned off is the one that will be selected when it is turned back on again.

2. Set the Flash Bar

The Flash Bar can be set anywhere from 2 to Apex (0). Use it as an estimate of the canal's working length.

Method

When the file is not inserted, hold down the Power Switch and then press the Set Switch at the same time. Each press of the Set Switch will move the Flash Bar one bar towards the Apex. The position will be automatically memorized.



CAUTION

- The Flash Bar cannot be set beyond the Apex.

Settings

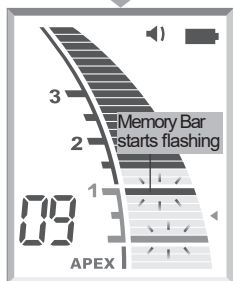
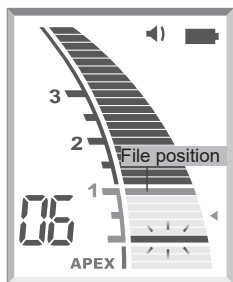

3. Memory Bar

The Memory Bar can be set anywhere up to APEX.

The Memory Bar can be set during treatment to mark a point of interest inside the canal such as the beginning of a curve, a certain distance from the apex, or the point to change file size for enlargement.

Method

Insert the file up to the desired point and then press the Set Switch. This will cause another bar to flash on and off at a slightly slower speed than the main Flash Bar. This will not change the point where the alarm is activated.



4. Beeper Volume

The volume of the beep can be set for Loud or Soft, or it can be turned off.

Method

Hold down the Set Switch and turn the Root ZX mini on.

This will change the setting of the beep from Loud to off.

Repeat the procedure to change it from off to Soft. The setting will be memorized and stay the same the next time you turn the unit on.



⚠ WARNING

- The Memory Bar should only be used as an estimate. You may need to change it during enlargement and cleaning. If there seems to be some problem, stop using the device immediately.
- Check the settings displayed after selecting memories.

⚠ CAUTION

- The Memory Bar cannot be set beyond the Apex.
- The Memory Bar can be set at a different point for each of the 3 memories.
- The Memory Bar will stay wherever you set it until the Root ZX mini is turned off, but it will not be memorized.
- The volume of the beep that sounds when the unit is turned on cannot be adjusted.

Meter Display

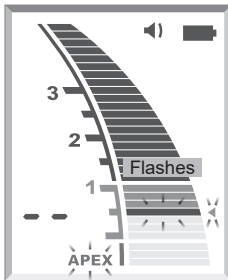
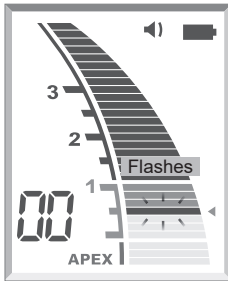
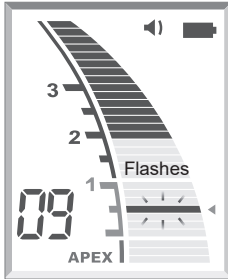

The position of the file tip is shown by the canal length indicator bar on the display. The Flash Bar flashes on and off once file is inserted into the root canal.



0.5 Meter Reading

The meter's 0.5 reading indicates that the file tip is located very near the physiological apical foramen. Use this position as a reference to determine the working length depending on the individual case. The exact working length depends on the shape and condition of the canal, and a clinical judgment must be made by the dentist.

* The numerals 1, 2, and 3 do not represent length in millimeters from the apex. These numbers are used to as a reference to determine the working length.

If the file tip reaches the apical foramen, a single, sustained beep will sound, and the word "APEX" and the little triangle next to the Flash Bar will start to flash on and off.

WARNING

- In some cases such as a blocked canal, an accurate apex location cannot be obtained. (For details, see "Root Canals Not Suitable for Electric Apex Location.")
- Make sure to take an X-ray to check the results. Accurate apex location may not always possible. It depends on tooth condition, case complexity, as well as degradation of the device.
- Stop using the device immediately if you sense something odd or abnormal while obtaining the apex location.

CAUTION

- Do not let the file touch the gums. This will cause the meter to jump to Apex.
- If the canal is extremely dry, the meter may not move until it is quite close to the apex. If the meter does not move, try moistening the canal with oxydol or saline.
- Occasionally the canal length indicator bar will make a sudden and large movement as soon as the file is inserted into the root canal, but it will return to normal as the file is advanced down towards the apex.

Operating the Unit

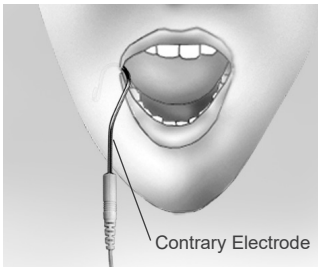

1. Turn the unit on.
2. Hook the contrary electrode in the corner of the patient's mouth.

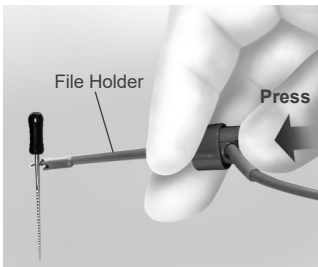

3. Clip the file holder to the metal shaft of the file.
 - (1) Press in direction of arrow with the thumb.
 - (2) Clip file.
 - (3) Release thumb.

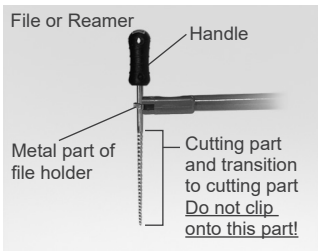

WARNING

- Do not use an ultrasonic scaler with the contrary electrode attached to the patient. Electrical noise from the scaler could interfere with an accurate apex location.
- Make sure that the contrary electrode, file holder etc. do not come into contact with an electric power source such as an electrical socket. This could result in a severe electrical shock.

CAUTION

- The contrary electrode could cause an adverse reaction if the patient has an allergy to metals. Ask the patient about this before using the contrary electrode.
- Take care that medicinal solutions such as formalin cresol (FC) or sodium hypochlorite do not get on the contrary electrode or the file holder. These could cause an adverse reaction such as inflammation.
- Always clip the file holder to the upper part of file shaft, near the handle. The metal and plastic part of the file holder can be damaged if they are attached to the file's cutting part or the transition to the cutting part.

Operating the Unit

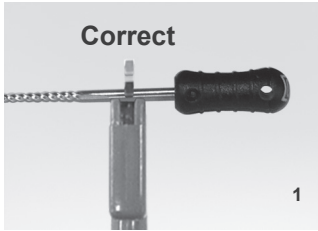

Set Switch

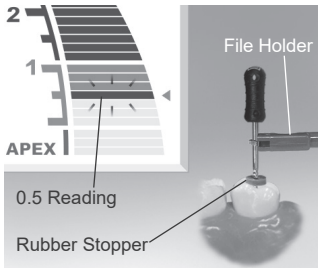
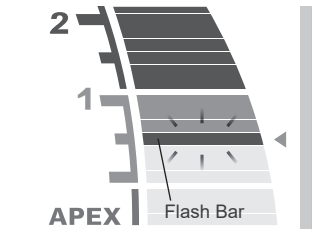

4. Press the Set Switch to select Memory 01, 02 or 03.

5. Insert the file up to the Flash Bar (this point can also be recognized by the change in the beeping). Position the rubber stopper on the tooth surface as a reference point to determine the root canal's working length. Use the 0.5 reading on the meter to estimate the canal's length.

6. Determine the working length.

0.5 Meter Reading

The meter's 0.5 reading indicates that the file tip is located very near the physiological apical foramen. Use this position as a reference to determine the working length depending on the individual case. The exact working length depends on the shape and condition of the canal, and a clinical judgment must be made by the dentist.

* The numerals 1, 2, and 3 do not represent length in millimeters from the apex. These numbers are used to as a reference to determine the working length.



When using the long file holder instead of the file holder



Long File Holder (Option)



CAUTION

- Use files and reamers with plastic handles only. If the file has a metal handle, electrical leakage will occur when the handle is touched by fingers and it will prevent an accurate apex location. Even if the file handle is made of plastic, make sure not to touch the metal part of the file with finger.
- Do not use damaged file holders. Otherwise, accurate apex location cannot be obtained.
- Clip the file as shown in illustration #1 to the left. If the file is in the position shown in illustration #2, an accurate apex location cannot be obtained, and the file holder may be damaged.
- Make sure to take an X-ray to check the results.
- Make sure the long file holder does not prick or pierce the patient's oral mucosa .

Root Canals Not Suitable for Electric Apex Location

Accurate apex location cannot be obtained with the root canal conditions shown below.



Root Canal with a large apical foramen

Tooth with incomplete root canal (e.g., root resorbed tooth and primary tooth).

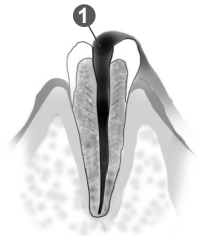

Root canal with blood overflowing from the opening

If blood overflows from the opening of the root canal and contacts the gums, this will result in electrical leakage and an accurate apex location cannot be obtained. Wait for bleeding to stop completely. Clean the inside and opening of the canal (1) thoroughly to get rid of all blood, and then check the apex location again.

Root canal with a chemical solution overflowing from the opening

An accurate apex location cannot be obtained if a chemical solution is overflowing from the canal opening. In this case, clean the canal and its opening, and then perform apex location.

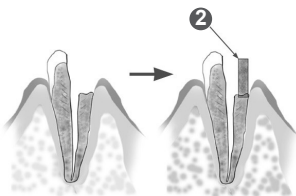

Broken crown

If the crown is broken and a section of the gingival tissue is contacting caries surrounding the canal opening, the Root ZX mini may malfunction due to electrical leakage between the gingival tissue and the root canal. In this case, build up the tooth with a suitable material such as cement (2), to insulate the gingival tissue.

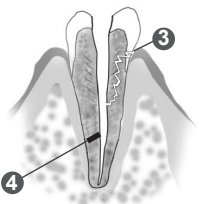

Fractured tooth

Leakage through a branch canal

A fractured tooth (3) will cause electrical leakage and accurate apex location cannot be obtained. A branch canal (4) will also cause electrical leakage and accurate apex location cannot be obtained.

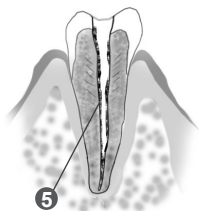

Re-treatment of a root filled with gutta-percha

The gutta-percha must be completely removed to eliminate its insulating effect. After removing the gutta-percha (5), pass a small file all the way through the apical foramen, and then put a little saline in the canal, but do not let it overflow the canal opening.

Root Canals Not Suitable for Electric Apex Location

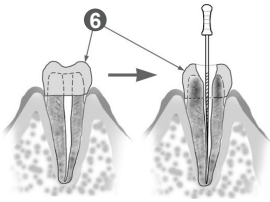

Crown or metal prosthesis touching gingival tissue

The Root ZX mini will malfunction if the file or reamer touches a metal prosthesis that is touching gingival tissue. In this case, widen the opening at the top of the crown (6) so that the file or reamer will not touch the metal prosthesis before performing the apex location.

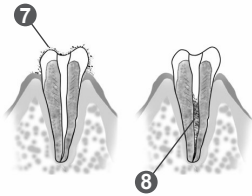

Cutting debris on tooth

Pulp inside canal

Thoroughly remove all cutting debris (7) from the tooth. Thoroughly remove all the pulp (8) inside the canal. Otherwise accurate apex location cannot be obtained.

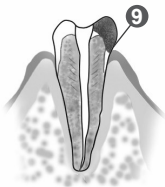

Caries touching the gums

In this case, electrical leakage through the caries infected area to the gums (9) will make it impossible to obtain an accurate apex location.

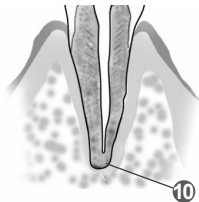

Blocked canal

The meter will not move if the canal is blocked (10). In this case, open the canal all the way (penetration) to the apical constriction.

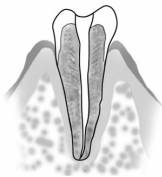

Extremely dry canal

If the canal is too dry, the meter may not move until the file is near the apex. In this case, try moistening the canal with oxydol or saline.

Root ZX mini Meter Reading and Radiography

Sometimes the Root ZX mini meter reading and the X-ray image will not correspond. This does not mean that the Root ZX mini is not working properly or that the X-ray exposure is a failure.

An X-ray image might not show the apex correctly depending on the angle of the X-ray beam, and the location of the apex might seem to be other than it really is.

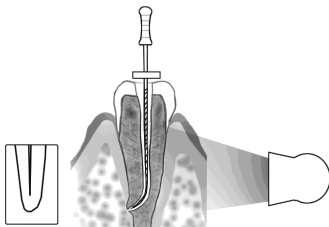

In the illustration above, the actual apex of the canal is not the same as the anatomical apex. There are frequently cases where the apical foramen is located up towards the crown.

In these cases, an X-ray might indicate that the file has not reached the apex even though it has actually reached the apical foramen.

3. After Using the Unit

1. Turn the unit off.

* The unit will automatically turn off after 10 minutes of non-use.

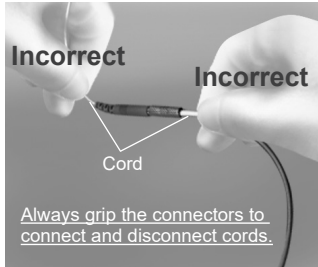

2. Disconnect the probe cord and other cords or cables.



CAUTION

- Do not pull directly on the cords when connecting or disconnecting the probe and file holder. Always grip the connectors to connect and disconnect cords.
- Do not wrap the probe cord around the body of the main unit.

4. Replacing Batteries



Replace the batteries as soon as the battery power indicator starts flashing.



* When battery power falls too much, an alarm will sound and the unit will automatically turn itself off.

1. Slide the cover in the direction by the arrow in the illustration and remove it from the Root ZX mini.

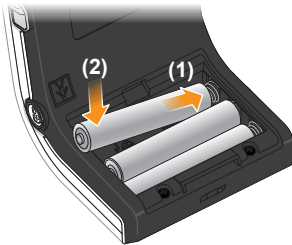

2. Insert the 3 LR03 (AAA size) batteries included in the package.

(1) Insert the batteries by first pressing center of the minus end against its spring contact.

(2) Slide the plus end down into place and make sure the contacts are not bent or damaged.

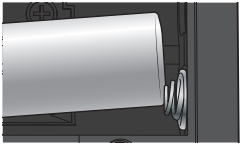

Incorrect



WARNING

- Never use the unit if the battery power indicator is flashing on and off. The unit may not function properly if the battery power is low.

CAUTION

- Do not reverse the plus and minus poles.
- Never allow the spring contact to push against the edge of the battery. This could damage the outer cover causing a short or a leakage of battery liquid.

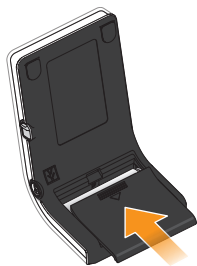

3. Slide the cover all the way down until it is securely closed.



- * Overheating or malfunctions could result if the above conditions are not adhered to.
- * The three LR03 alkaline dry cells used for this device will last for about 70 hours of use. (This equals 6 to 12 months at the normal rate of usage.)

CAUTION

- After installation, give the cover a light tug to confirm it is securely attached.
- Always use LR03 alkaline, Oxyride™, or manganese dry cells. (Manganese dry cells will not last as long as Oxyride™ or alkaline dry cells.) Never use rechargeable nickel-hydrogen or nickel-cadmium batteries.
- All the dry cells should be of the same type: i.e., all alkaline, all Oxyride™, or all manganese.
- Replace all three batteries at the same time.
- Never use batteries that are leaky, deformed, discolored or otherwise abnormal.
- Dispose of old batteries according to local codes and regulations.
- In case of battery leakage, carefully dry the battery terminals and remove all of the leaked liquid. Replace the battery with a new one.

Reprocessing

There are two ways to perform reprocessing depending on the items.

Parts to be Sterilized

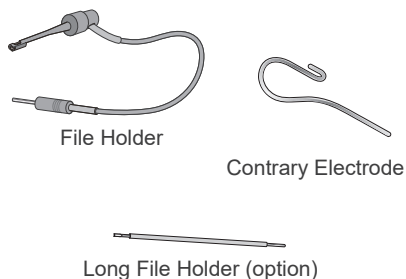

Parts to be Disinfected

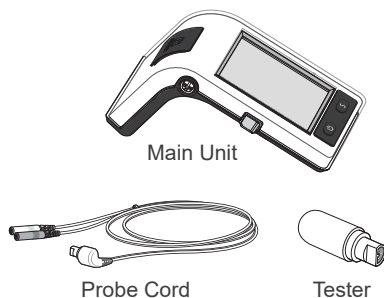

- ! After use, perform reprocessing promptly.
- ! Before reprocessing, make sure that all the parts (e.g., file, file holder, etc.) are separated individually.

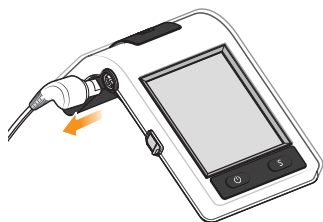

Preparation

Turn off the power.
Disconnect all parts.

WARNING

- Be careful to avoid cross infection when performing reprocessing.
- Always wear personal protective equipment (PPE) such as safety glasses, gloves, a mask, etc. when performing the reprocessing procedures.

CAUTION

- When performing reprocessing, always turn off the device and make sure that the device will not operate.
- Be careful when clipping and unclipping files to avoid injury to fingers.

1. Parts to be Sterilized

* Be sure to perform the reprocessing procedures in the following order promptly after use with each patient.

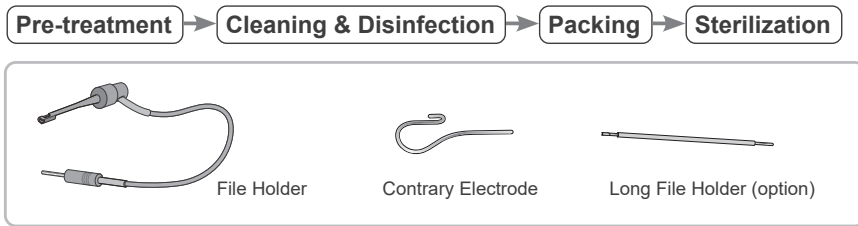

Pre-treatment

This must be performed after use with each patient.

- ❗ After use, perform reprocessing promptly. If the parts are left contaminated with blood, it will be difficult to remove.
- ❗ Do not use any chemicals that may coagulate proteins before cleaning.
- ❗ If a medical agent being used for the treatment has adhered to the part, wash it off under tap water.
- ❗ Be careful not to tug on the cord when you clean the file holder. This could cause the wire to break.
- ❗ Do not clean the parts with an ultra sonic cleaning device.

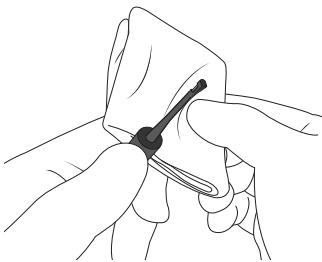
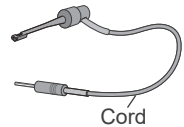

Wipe the parts with a piece of gauze or microfiber cloth (e.g., Toraysee for CE - Medical Equipment and Instruments Maintenance Cloth) that has been dampened with tap water to remove visible contaminants.



Alternatively, clean the parts in running water with a soft brush to remove visible contaminants.

⚠ WARNING

- To prevent the spread of infections, be sure to perform the reprocessing procedures after use with each patient.

Cleaning & Disinfection



- ! Be sure to remove visible contaminants before this step.
- ! Be sure to use washer-disinfectors that conform to ISO 15833-1 (must be capable of achieving disinfection values of not less than $A_0 = 3000$).
- ! If your region is susceptible to hard water scale buildup, use deionized water (ion-exchanged water).
- ! For details on handling detergents and neutralizers, concentration, water quality as well as parts washing baskets, refer to the accompanying user manual for the washer-disinfector.
- ! Inappropriate cleaning methods and solutions may damage the parts.
- ! Do not use strong acidic or alkaline chemicals that could cause the metal to corrode.
- ! Do not start drying when the interior of the part is filled with water. Otherwise, this could result in corrosion of the part due to condensation of the rinsing solution.
- ! After completing the cleaning process, expel remaining moisture inside the parts with compressed air.
- ! Do not leave the parts in the washer-disinfector. This may cause corrosion or malfunction of the parts.
- ! Parts' surface may get scratched and wear out during the cleaning process due to contact with the parts washing basket or other parts. Replace the parts as necessary depending on degree of scratches and wear.



Recommended Conditions for Washer-Disinfectors

Unit Name	Miele G7881
Mode	Vario TD
Detergent (concentration)	neodisher MediClean (0.3% to 0.5%)
Rinse (concentration)	neodisher MediKlar (0.02% to 0.04%)

Put parts in the parts washing basket.

Select the washer-disinfector's mode as shown in the chart and start the process.

After completing the cleaning process, make sure the parts are thoroughly clean.

Expel remaining moisture on the surface or inside the parts with compressed air.

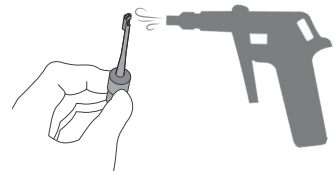

After cleaning there may be streaks or white spots on the parts. Use a neutralizer only if there are streaks or white spots.

WARNING

- If any moisture is left inside the parts after cleaning, it could cause corrosion or poor sterilization. Also, the remaining water may come out during use. After cleaning, use a syringe or compressed air to expel remaining moisture.

CAUTION

- Dust and other impurities adhering to the file holder's electrical contacts or hook can cause the device to malfunction.



Packing

- ! Use sterilization pouches that conform to ISO 11607.
- ! Do not use any sterilization pouches that contain hydro-soluble adhesive ingredients such as PVA (polyvinyl alcohol).
Note that even ISO 11607 conformable sterilization pouches may contain PVA.
- ! When placing a part in a sterilization pouch, be sure not to put stress on the part (e.g., cord).

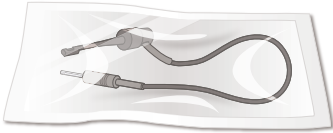

Place the parts individually in a sterilization pouch.
Use only FDA-cleared pouches. (Only for U.S.A.)

Sterilization

- ! Do not sterilize the parts by any method other than autoclaving.
- ! If chemical solutions or foreign debris are not removed, autoclaving could damage or discolor the part. Thoroughly clean and sterilize the parts before autoclaving.
- ! The setting temperature for sterilization and drying process must be +135°C (+275°F) or lower. If the temperature is set at beyond +135°C (+275°F), it may cause a malfunction or stain on the parts.
- ! Do not autoclave any parts other than the file holder, contrary electrode, and Long File Holder (option).
- ! Take the file out of the file holder before autoclaving.
- ! Follow the manufacturer's recommendations for autoclaving files.
- ! After completing the autoclaving process, do not leave the parts in the autoclave.



Recommended Autoclave Settings

Country: U.S.A.

Sterilizer Type	Temperature	Time	Drying Time after Sterilization
Gravity	+132°C (+269.6°F)	15 minutes	15 minutes
	+121°C (+249.8°F)	30 minutes	

Country: Other than U.S.A.

Sterilizer Type	Temperature	Time	Drying Time after Sterilization
Dynamic Air Removal	+134°C (+273.2°F)	3 minutes	10 minutes
	+134°C (+273.2°F)	5 minutes	
Gravity	+134°C (+273.2°F)	min. 6 minutes	min. 10 minutes
	+121°C (+249.8°F)	min. 60 minutes	

Autoclave the autoclavable parts.

After autoclaving, store the parts in a clean and dry environment.

WARNING

- To prevent the spread of infections, the parts must be autoclaved after each patient's treatment has been completed.

CAUTION

- Parts are extremely hot right after autoclaving. Wait for them to cool off before touching.

2. Parts to be Disinfected

* Be sure to perform reprocessing procedures in the following order promptly after use with each patient.

Pre-treatment

Cleaning & Disinfection



Main Unit



Probe Cord



Tester

Pre-treatment

This must be performed after use with each patient.

- ! After use, perform reprocessing promptly. If the parts are left contaminated with blood, it will be difficult to remove.
- ! Do not use any chemicals that may coagulate proteins before cleaning.
- ! If a medical or adhesive agent being used for the treatment has adhered to the part, immediately remove it with a piece of gauze or microfiber cloth (e.g., Toraysee for CE - Medical Equipment and Instrument Maintenance Cloth) that has been dampened with tap water.
- ! Be sure not to tug on the cable when you clean the parts. This could cause the wire to break.



- ! Do not clean the parts with an ultra sonic cleaning device.
- ! Do not wet the electrical contacts.

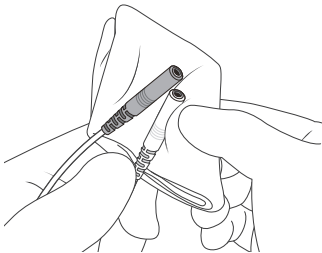

Wipe the parts with a piece of gauze or microfiber cloth (e.g., Toraysee for CE - Medical Equipment and Instruments Maintenance Cloth) that has been dampened with tap water to remove visible contaminants. Then wipe off moisture completely with a soft cloth.

Cleaning & Disinfection

- ❗ Make sure that there is no visible moisture and contamination when wiping the parts.
- ❗ Be sure not to tug on the cable when you clean the parts. This could cause the wire to break.
- ❗ Do not use disinfectants other than those designated by J. MORITA MFG. CORP.
- ❗ For details on handling disinfectants, refer to the accompanying user manual for each disinfectant.
- ❗ If too much disinfectant is applied to the piece of gauze or microfiber cloth, it will seep into the part and cause a malfunction.
- ❗ Do not immerse the parts in or wipe them with any of the following: functional water (acidic electrolyzed water, strong alkaline solution, and ozone water), medical agents (glutaral, etc.), or any other special types of water or commercial cleaning liquids. Such liquids may result in metal corrosion or adhesion of the residual medical agent to the parts.
- ❗ Do not clean or immerse the parts with chemicals such as formalin cresol (FC) and sodium hypochlorite. These will damage the metal and plastic parts. Immediately wipe away any chemicals that are accidentally spilled on the parts.

Disinfectants Approved by J. MORITA MFG. CORP.

Disinfectant	Country
Ethanol (70 vol% to 80 vol%)	U.S.A.
Opti-Cide3 (wipes)	
Dürr FD333 forte (wipes)	Other than U.S.A.

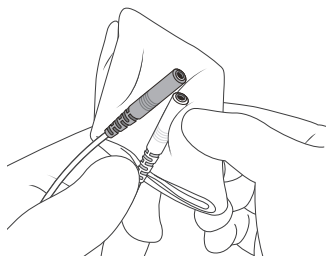

Wipe the part's surface with disinfectants approved by J. MORITA MFG. CORP.

Replacement Parts, Transport and Storage

Replacement Parts

- * Replace the parts as necessary depending on degree of wear and length of use.
- * Order replacement parts from your local dealer or J. MORITA OFFICE.

Transport and Storage Environments

Temperature: -10°C to +45°C (+14°F to +113°F)

Humidity: 10% to 85% (without condensation)

Atmospheric pressure: 70 kPa to 106 kPa

- ! Do not expose to X-rays or direct sunlight frequently or for long times.
- ! If the unit has not been used for a long time, make sure it works properly before using.
- ! Always remove the batteries prior to storing or shipping the unit.

Inspection

- Maintenance and inspection are generally considered to be the duty and obligation of the user, but if, for some reason, the user is unable to carry out these duties, contact J. MORITA MFG. CORP. for details.
- Replace the parts listed in the Parts Lists as necessary depending on degree of wear and length of use.
- This apparatus should be inspected every 6 months in accordance with the following maintenance and inspection items.
- J. MORITA MFG. CORP. will supply replacement parts and be able to repair the product for a period of 10 years after the manufacture of the product has been discontinued. For the duration of this period, we will supply replacement parts and be able to repair the product.

Maintenance and Inspection Items

1. Check that the Power switch turns the unit on and off properly.
2. Insert the Tester and check that the indicator is within ± 3 lines of 1 on the meter.
3. Check that the Set switch changes the memory from 01 to 02 to 03.
4. Check that the probe cord can be properly plugged into its jack.
5. Check that the file holder's plug can be connected properly to the probe cord and that the file holder can be clipped onto a file. Check the contrary electrode can be plugged into its probe cord connector.
6. Touch the contrary electrode with the file holder and make sure all the bars on the meter light up.
7. This device should be inspected after prolonged unusual period.

Parts Lists

File Holders (5)
Code No. 7503670

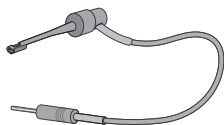

Contrary Electrodes (5)
Code No. 7503680



Tester
Code No. 8456089

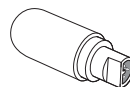

Probe Cord
Code No. 8449716



Long File Holders (5)
Code No. 8447055

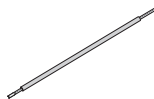

Battery Cover
Code No. 4001234



■ Disposal of Medical Devices

Any medical devices which could possibly be contaminated must be first decontaminated by the responsible doctor or medical institution and then be disposed of in accordance with local laws and regulations.

The battery should be recycled. Metal parts of the device are disposed as scrap metal. Synthetic materials, electrical components, and printed circuit boards are disposed as electrical scrap. Material must be disposed according to the relevant national legal regulations. Consult specialized disposal companies for this purpose. Please inquire of the local administration concerning local disposal companies.

■ Service

The Root ZX mini may be repaired and serviced by:

- The technicians of J. MORITA's subsidiaries all over the world.
- Technicians employed by authorized J. MORITA dealers and specially trained by J. MORITA.
- Independent technicians specially trained and authorized by J. MORITA.

Troubleshooting

If the device does not seem to be working properly, the user should first try to inspect and adjust it himself.

* If the user is unable to inspect the device himself or if the device fails to work properly after being adjusted or after parts are replaced, contact your local dealer or J. MORITA OFFICE.

Problem	Check Points	Response
No power	Check battery installation. Check battery power.	Install batteries properly. Replace batteries.
Cannot perform apex location.	Is the contrary electrode properly hooked in the corner of the patient's mouth? Check cord connections. Check probe cord for broken wire.	Hook it in the corner of the patient's mouth. Check that all connections are properly secured. Touch the contrary electrode to the file holder to check probe cord conductivity.
No alarm sound.	Check if sound is turned off.	Turn the sound on.
Cannot switch memories. Cannot change memory settings.	Is apex location being performed? Does the switch work?	You cannot operate anything other than the power switch during apex location. Switch may be broken.
Display does not appear.	Try replacing the dry cells.	If new dry cells do not solve the problem, the LCD may be malfunctioning.
Canal Length Indicator is unstable.	Is contrary electrode making good contact with oral mucosa? Is the file holder dirty?	Make sure the contrary electrode makes good contact with the oral mucosa. Clean the file holder with disinfectant.
The display of the canal length indication bars makes abnormal movements as follows. • Too short • Inaccurate • Too sensitive	Is blood or saliva overflowing from the opening of the crown? Is the canal filled with blood, saliva or chemical solutions? Is the tooth surface covered with cutting debris or chemical solutions? Is the file touching the gingival tissue? Is there pulp tissue left inside the root canal? Is the file touching a metal prosthesis? Are proximal surfaces infected with caries?	If blood or other fluids overflow the canal, the current will leak to the gums and the meter will jump to Apex. Clean the canal, canal opening and tooth crown thoroughly. The canal length indicator bar may suddenly swing when it breaks the surface of fluids inside the canal, but it will return to normal as the file is advanced down toward the apex. Clean entire tooth surface. This will cause the canal length indicator bar to suddenly jump all the way to the "APEX". Accurate apex location cannot be obtained if a large amount of pulp tissue is left inside the root canal. Touching a metal prosthesis with the file allows a flow of current to the gingival tissue or periodontal pocket and will cause the meter to jump to the "APEX". When the electrical current flows through the caries infected area to the gums, an accurate apex location cannot be obtained.

Problem	Check Points	Response
<p>The display of the canal length indication bars makes abnormal movements as follows.</p> <ul style="list-style-type: none"> • Too short • Inaccurate • Too sensitive 	<p>Are there lateral canals or is the tooth fractured?</p> <p>Does a broken crown allow leakage of electric current?</p> <p>Is there a lesion at the apex?</p> <p>Is the file holder broken or dirty?</p>	<p>The canal length indicator bar may jump to "APEX" when it reaches the opening of a lateral canal or the opening of a fractured tooth that allows the current to flow to the gingival tissue.</p> <p>Build up an insulating barrier to stop the leakage.</p> <p>If there is a periapical lesion, physiological tissue is absorbed and accurate apex location may not be obtained.</p> <p>Replace or clean the file holder.</p>
<p>Canal Length Indicator does not move at all or only when the file tip is close to the apical foramen.</p>	<p>Is the canal blocked?</p> <p>Is the apical foramen very large and open?</p> <p>Is the canal extremely dry?</p>	<p>Open the canal all the way (patency) to the apical constriction.</p> <p>If the apical foramen is large or wide open and not completely formed, the canal length indicator bar will suddenly jump when the file tip gets close to the apex.</p> <p>Moisten the canal with oxydol or a saline solution.</p>
<p>Cannot set Memory Bar for file tip at desired point.</p>	<p>Is desired indicator bar lit up?</p> <p>Did you press the Set switch?</p> <p>Has file tip gone beyond Apex Bar?</p>	<p>Advance file to desired point.</p> <p>Press Set switch firmly.</p> <p>Move file tip up above the Apex Bar.</p>

Technical Specifications

Specifications

*Specifications may be changed without notice due to improvements.

Name	Root ZX mini
Model	RCM-7
Degree of Protection	IPX0
Protection against Electric Shock	Internal powered ME equipment / Type BF applied part
Intended Use	The Root ZX mini is intended to detect the apex of the root canal.
Operating Principle	The impedance in the root canal is determined by measuring at two frequencies and the position of the file in the root canal is detected.
Essential Performance	None (There is no unacceptable risk.)

■ Main Unit

Rated Input Voltage	DC 4.5 V (three alkaline dry cells [LR03 "AAA size" batteries])
Dimensions	Approx. Height 57 × Width 60 × Length 103 mm
Weight	Approx. 110 g
Applied Part	File holder, Contrary electrode

Symbols

* Some symbols may not be used.



CE(0197) marking
Conforms with the European Directive, 93/42/EEC.
CE marking
Conforms with the European Directive, 2011/65/EU.



Unique device identifier



Type BF applied part



Manufacturer



Marking of electrical Equipment in accordance with the European Directive 2012/19/EU (WEEE)

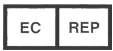

EU Authorized Representative under the European Directive 93/42/EEC



Keep away from rain



Fragile



Temperature limitation

Non-Sterile Sterilize components before use



Serial number



Medical device



GS1 DataMatrix



Date of manufacture



Autoclavable up to +135°C (+275°F)



Consult instructions for Use



This way up



Atmospheric pressure limitation



Humidity limitation

Rx Only Prescription Device
CAUTION: Federal law restricts this device to sale by or on the order of a dentist. (Valid only for U.S.A.)



INMETRO certification mark (Valid only for Brazil)



Authorized representative in Switzerland



Importer



Distributor



Country or region
(Country Names: Conforming to the ISO 3166-1 alpha-3 codes and EU for European Union)
Description noted next to the code is an indication that conforms to the regulations valid only for the relevant country or region.

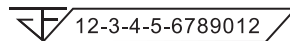

Registration number of medical device in Thailand

(The 12-digit sample number shown is for demonstration purposes only.)

Electromagnetic Disturbances (EMD)

The Root ZX mini (hereafter “this device”) conforms to IEC 60601-1-2:2014 Ed. 4.0, the relevant international standard for electromagnetic disturbances (EMD).

The following is the “Guidance and Manufacturer’s Declaration” which is required by IEC 60601-1-2:2014 Ed. 4.0, the relevant international standard for electromagnetic disturbances.

This is a Group 1, Class B product according to EN 55011 (CISPR 11).

This means that this device does not generate and/or use internationally radio-frequency energy, in the form of electromagnetic radiation, inductive and/or capacitive coupling, for the treatment of material or inspection/analysis purpose and that it is suitable for use in domestic establishments and in establishments directly connected to a low voltage power supply network which supplies buildings use for domestic purposes.



Guidance and Manufacturer’s Declaration – Electromagnetic Emissions		
This device is intended for use in the electromagnetic environment specified below. The customer or the user of this device should assure that it is used in such an environment.		
Emissions Test	Compliance	Electromagnetic Environment – Guidance
Conducted disturbance CISPR 11	Group 1 Class B	This device uses RF energy only for its internal function. Therefore, its RF emissions are very low and are not likely to cause any interference in nearby electronic equipment.
Radiated disturbance CISPR 11	Group 1 Class B	This device is suitable for use in all establishments, including domestic establishments and those directly connected to the public low-voltage power supply network that supplies buildings used for domestic purposes.
Harmonic current* ¹ IEC 61000-3-2	Class A	
Voltage fluctuations and flicker* ¹ IEC 61000-3-3	Clause 5	

*1: The test is not applicable since the EUT does not have AC ports.

WARNING

- The use environment of this device is the Home healthcare environment.
- This device needs special precautions regarding EMD and needs to be installed and put into service according to the EMD information provided in the ACCOMPANYING DOCUMENTS.
- Use of parts other than those accompanied or specified by J. MORITA MFG. CORP. could result in increased electromagnetic emissions or decreased electromagnetic immunity of this device and result in improper operation.
- Do not use this device as adjacent or stacked as possible with other. When adjoining or stacking is necessary, use it after observing whether this device and other equipment work properly.
- Portable and mobile RF communications equipment (including peripherals such as antenna cables and external antennas) should be used no closer than 30 cm to any part of the RCM-7, including cables specified by the manufacturer.

Guidance and Manufacturer's Declaration – Electromagnetic Immunity			
This device is intended for use in the electromagnetic environment specified below. The customer or the user of this device should assure that it is used in such an environment.			
Immunity Test	IEC 60601 Test Level	Compliance Level	Electromagnetic Environment – Guidance
Electrostatic discharge (ESD) IEC 61000-4-2	±8 kV contact ±2 kV, ±4 kV, ±8 kV, ±15 kV air	±2 kV, ±4 kV, ±6 kV, ±8 kV contact ±2 kV, ±4 kV, ±8 kV, ±15 kV air	Floors should be wood, concrete or ceramic tile. If floors are covered with synthetic material, the relative humidity should be at least 30%.
Electrical fast transients/bursts IEC 61000-4-4	±2 kV for power supply lines ±1 kV for input/output lines	±2 kV for power supply lines ±1 kV for input/output lines	Mains power quality should be that of a typical commercial or hospital environment.
Surge*1 IEC 61000-4-5	<u>AC/DC power</u> ±0.5 kV, ±1 kV line(s) to line(s) ±0.5 kV, ±1 kV, ±2 kV line(s) to earth <u>Signal input/output</u> ±2 kV line(s) to earth	<u>AC/DC power</u> ±0.5 kV, ±1 kV line(s) to line(s) ±0.5 kV, ±1 kV, ±2 kV line(s) to earth <u>Signal input/output</u> ±2 kV line(s) to earth	Mains power quality should be that of a typical commercial or hospital environment.
Voltage dips, short interruptions and voltage variations on power supply lines*1 IEC 61000-4-11	<u>dips</u> 0% U_T : 0.5 cycle (at 0, 45, 90, 135, 180, 225, 270, 315°) 0% U_T : 1 cycle (at 0°) 70% U_T : 25/30 cycles (at 0°) 25 (50 Hz)/30 (60 Hz) <u>short interruptions</u> 0% U_T : 250/300 cycles 250 (50 Hz)/300 (60 Hz)	<u>dips</u> 0% U_T : 0.5 cycle (at 0, 45, 90, 135, 180, 225, 270, 315°) 0% U_T : 1 cycle (at 0°) 70% U_T : 25/30 cycles (at 0°) 25 (50 Hz)/30 (60 Hz) <u>short interruptions</u> 0% U_T : 250/300 cycles 250 (50 Hz)/300 (60 Hz)	Mains power quality should be that of a typical commercial or hospital environment. If user of this device requires continued operation during power mains interruptions, it is recommended that this device be powered from an uninterruptible power supply or a battery.
Power frequency (50/60 Hz) magnetic field IEC 61000-4-8	30 A/m (r.m.s.) 50 Hz or 60 Hz	30 A/m (r.m.s.) 50 Hz or 60 Hz	Power frequency magnetic field should be at levels characteristic of a typical location in a typical commercial or hospital environment.
NOTE 1: U_T is the a.c. mains voltage prior to application of the test level. NOTE 2: r.m.s.: root mean square			

*1: The test is not applicable since the EUT does not have AC ports.

Guidance and Manufacturer's Declaration – Electromagnetic Immunity			
This device is intended for use in the electromagnetic environment specified below. The customer or the user of this device should assure that it is used in such an environment.			
Immunity Test	IEC 60601 Test Level	Compliance Level	Electromagnetic Environment – Guidance
Conducted RF IEC 61000-4-6	3 V ISM ^(a) / amateur radio frequency band: 6 V 150 kHz to 80 MHz	3 V ISM ^(a) / amateur radio frequency band: 6 V 150 kHz to 80 MHz	Portable and mobile RF communications equipment should be used no closer to any part of this device, including cables, than the recommended separation distance calculated from the equation applicable to the frequency of the transmitter. Recommended separation distances $d = 1.2 \sqrt{P}$ 150 kHz to 80 MHz $d = 0.4 \sqrt{P}$ 80 MHz to 800 MHz $d = 0.7 \sqrt{P}$ 800MHz to 2.7 GHz $d = \frac{6}{E} \sqrt{P}$ Portable wireless RF communication equipment Where P is the maximum output power rating of the transmitter in watts (W) according to the transmitter manufacturer, E is the compliance level in V/m and d is the recommended separation distance in meters (m). Field strengths from field RF transmitters, as determined by an electromagnetic site survey ^(a) , should be less than the compliance level in each frequency range ^(b) . Interference may occur in the vicinity of equipment marked with the following symbol: 
Radiated RF IEC 61000-4-3	10 V/m 80 MHz to 2.7 GHz	10 V/m 80 MHz to 2.7 GHz	
	27 V/m 385 MHz	27 V/m 385 MHz	
	28 V/m 450 MHz	28 V/m 450 MHz	
	9 V/m 710, 745, 780 MHz	9 V/m 710, 745, 780 MHz	
	28 V/m 810, 870, 930, MHz	28 V/m 810, 870, 930, MHz	
	28 V/m 1720, 1845, 1970 MHz	28 V/m 1720, 1845, 1970 MHz	
	28 V/m 2450 MHz	28 V/m 2450 MHz	
	9 V/m 5240, 5500, 5785 MHz	9 V/m 5240, 5500, 5785 MHz	
NOTE 1: At 80 MHz and 800 MHz, the higher frequency range applies.			
NOTE 2: These guidelines may not apply in all situations. Electromagnetic propagation is affected by absorption and reflection from structures, objects and people.			
<p>(a) Field strengths from fixed transmitters, such as base stations for ratio (cellular/cordless) telephones and land mobile radios, amateur radio, AM and FM radio broadcast and TV broadcast cannot be predicated theoretically with accuracy. To assess the electromagnetic environment due to fixed RF transmitters, an electromagnetic site survey should be considered. If the measured field strength in the location in which this device is used exceeds the applicable RF compliance level above, this device should be observed to verify normal operation. If abnormal performance is observed, additional measures may be necessary, such as reorienting or relocating this device.</p> <p>(b) Over the frequency range 150 kHz to 80 MHz, field strengths should be less than 3 V/m.</p> <p>(c) The ISM (Industrial, Scientific and Medical) bands between 0.15 MHz and 80 MHz are 6.765 MHz to 6.795 MHz; 13.553 MHz to 13.567 MHz; 26.957 MHz to 27.283 MHz; and 40.66 MHz to 40.70 MHz. The amateur radio bands between 0.15 MHz and 80 MHz are 1.8 MHz to 2.0 MHz, 3.5 MHz to 4.0 MHz, 5.3 MHz to 5.4 MHz, 7 MHz to 7.3 MHz, 10.1 MHz to 10.15 MHz, 14 MHz to 14.2 MHz, 18.07 MHz to 18.17 MHz, 21.0 MHz to 21.4 MHz, 24.89 MHz to 24.99 MHz, 28.0 MHz to 29.7 MHz and 50.0 MHz to 54.0 MHz.</p>			

Essential Performance

None

Cable List

No.	Interface(s):	Max. Cable Length, Shielding	Cable Classification
1.	Probe Cord	1.7 m, Un-shielded	Signal Line (Patient-Coupled Cable)



Development and Manufacturing

J. MORITA MFG. CORP.

680 Higashihama Minami-cho, Fushimi-ku,
Kyoto 612-8533, Japan
T +81. (0)75. 611 2141, F +81. (0)75. 622 4595

Morita Global Website
www.morita.com

Distribution

J. MORITA CORP.

3-33-18 Tarumi-cho, Suita-shi, Osaka 564-8650, Japan
T +81. (0)6. 6380 1521, F +81. (0)6. 6380 0585

J. MORITA USA, INC.

9 Mason, Irvine CA 92618, USA
T +1. 949. 581 9600, F +1. 949. 581 8811

J. MORITA EUROPE GMBH

Justus-von-Liebig-Strasse 27b, 63128 Dietzenbach, Germany
T +49. (0)6074. 836 0, F +49. (0)6074. 836 299

MORITA DENTAL ASIA PTE. LTD.

150 Kampong Ampat #06-01A KA Centre, Singapore 368324
T +65. 6779. 4795, F +65. 6777. 2279

J. MORITA CORP. AUSTRALIA & NEW ZEALAND

Suite 2.05, 247 Coward Street, Mascot NSW 2020, Australia
T +61. (0)2. 9667 3555, F +61. (0)2. 9667 3577

J. MORITA CORP. MIDDLE EAST

4 Tag Al Roasaa, Apartment 902, Saba Pacha 21311 Alexandria, Egypt
T +20. (0)3. 58 222 94, F +20. (0)3. 58 222 96

J. MORITA CORP. INDIA

Felix Office No.908, L.B.S. Marg, Opp. Asian Paints, Bhandup (West), Mumbai 400078, India
T +91-82-8666-7482

J. MORITA MFG. CORP. INDONESIA

28F, DBS Bank Tower, Jl. Prof. Dr. Satrio Kav. 3-5, Jakarta 12940, Indonesia
T +62-21-2988-8332, F + 62-21-2988-8201

SIAMDENT CO., LTD.

71/10 Moo 5 T, Tharkham A. Bangpakong Chachuengsao 24130 Thailand
T +66 (0) 3857 3042, F +66 (0) 3857 3043

www.siamdent.com

EU Authorized Representative under the European Directive 93/42/EEC

EC REP Medical Technology Promedt Consulting GmbH

Ernst-Heckel-Straße 7, 66386 St. Ingbert, Germany T +49. 6894 581020, F +49. 6894 581021

The authority granted to the authorized representative, Medical Technology Promedt Consulting GmbH, by J. MORITA MFG. CORP. is solely limited to the work of the authorized representative with the requirements of the European Directive 93/42/EEC for product registration and incident report.

Diagnostic and Imaging Equipment

Treatment Units

Handpieces and Instruments

Endodontic Systems

Laser Equipment

Laboratory Devices

Educational and Training Systems

Auxiliaries

