

Dental X-ray Unit

Veraview iX

(Model V080)

INSTRUCTIONS FOR USE

(RAL)



Thank you for purchasing the Veraview iX.

For optimum safety and performance, read this manual thoroughly before using the unit and pay close attention to warnings and notes. Keep this manual in a readily accessible place for quick and easy reference.

Instructions for Use in Electronic Format (eIFU)



The electronic data (PDF document) of the Instructions for Use is available. Scan the following QR code and visit our website.



In order to view PDF documents, you will need the free Adobe Acrobat Reader distributed by Adobe Inc. Download the latest version via the Adobe website. PDF documents may not be displayed correctly using previous versions.

Trademarks and Registered Trademarks:

Parts of the names of companies, products, services, etc. used in this manual may contain either trademarks or registered trademarks owned by each company.

© 2017 J. MORITA MFG. CORP.

Table of Contents

Prevent Accidents	2
Warnings and Cautions	4
Parts Identification	6
Usage	9
(1) Before Use.....	9
(2) Use.....	10
Selecting the exposure parameters.....	10
Selecting radiography conditions.....	11
Positioning the patient.....	12
Taking an exposure.....	14
(3) After Use.....	16
Turn the Power Switch Off.....	16
(4) User Setting.....	17
Startup settings for radiography conditions and sleep mode time.....	17
Setting the timer table.....	19
Timer table.....	20
Dose area product.....	22
Maintenance, Parts Replacement, and Storage	23
(1) Maintenance (Cleaning and Disinfection).....	23
(2) Replacement Parts.....	24
(3) Optional Parts.....	24
(4) Storage.....	24
Maintenance and Inspection	25
Service Life	26
Troubleshooting	27
Technical Specifications	28
Specifications.....	28
Symbols and Markings.....	35
Electromagnetic Disturbances (EMD)	37

Prevent Accidents

Attention Customers

Do not fail to receive clear instructions concerning the various ways to use this equipment as described in this accompanying Instructions for Use.

To access the warranty information for this product, scan the following QR code and visit our website.



Attention Dealers

Do not fail to give clear instructions concerning the various ways to use this equipment as described in this accompanying Instructions for Use.

Safety Instructions and Recording Information

When the Veraview iX is installed, the installer or other responsible party must explain the precautions and usages in the Instructions for Use to the user and the person responsible for maintenance and management.

In accordance with the laws of the relevant country or region, information such as the installation date, explained contents, the name of operator and healthcare facility's maintenance representative, and the name of the installer or other responsible party, may need to be recorded.

Prevent Accidents

Most operation and maintenance problems result from insufficient attention being paid to basic safety precautions and not being able to foresee the possibilities of accidents. Problems and accidents are best avoided by foreseeing the possibility of danger and operating the unit in accordance with the manufacturer's recommendations. First thoroughly read all precautions and instructions pertaining to safety and accident prevention; then, operate the equipment with the utmost caution to prevent either damaging the equipment itself or causing bodily injury.



The following symbols and expressions indicate the degree of danger and harm that could result from ignoring the instructions they accompany:

WARNING

This warns the user of the possibility of extremely serious injury or complete destruction of the equipment as well as other property damage including the possibility of fire.

CAUTION

This warns the user of the possibility of mild injury or damage to the equipment.

* The warning symbols () and caution symbols () that appear next to the main text on the right hand side of the page refer to and are explained by the Warnings and Cautions at the bottom of the page.

(Usage Note)

This alerts the user of important points concerning operation or the risk of equipment damage.

The user (e.g., healthcare facility, clinic, hospital etc.) is responsible for the management, maintenance, and use of medical devices.

Disregarding the information on safety is considered ABNORMAL USE.

Do not use this equipment for anything other than its specified dental treatment purpose.

Intended Operator Profile

a) Qualification:

Legally qualified person such as radiologic technician and dentists for X-ray device operation (it may differ among countries).

b) Education and Knowledge:

It is assumed that the user understands the risks of X-rays and the protective steps required. It is also assumed that the user is thoroughly familiar with X-ray diagnosis, anatomy, and hygiene including the prevention of cross contamination.

c) Language Understanding:

English (Intended for professional use as described above).

d) Experience:

Experienced Person with operating X-ray devices.

No special training is required except in cases where this is required by legal regulations of the relevant country or region.

Related Documents

- Installation Instructions

The Useful Life

- The useful life of the Veraview iX is 10 years from the date of installation provided it is regularly and properly inspected and maintained.
- J. MORITA MFG. CORP. will supply replacement parts and be able to repair the product for a period of 10 years after the manufacture of the product has been discontinued.

In Case of Accident

For customers who use the Veraview iX in the EU:

If any serious incident occurs in relation to the device, report it to a competent authority of your country, as well as the manufacturer through your regional distributor. Observe relevant national regulations for detailed procedures.

Warnings and Cautions

WARNING

- This X-ray unit may be dangerous to PATIENT and OPERATOR unless safe exposure factors and Instructions for Use are observed.
- Only dentists and other legally qualified and authorized personnel are allowed to operate this equipment.
- Do not use this equipment for patients when it is being maintained or serviced.
- Make sufficient space around the power switch so that it is easily accessible in case of emergency.
- Make sufficient space around the power plug so that it is easily unplugged in case of emergency (R-Type).
- Make sufficient space around the power distribution panel so that it is easily turned the breaker open in case of emergency (WA-Type).
- To avoid the risk of electric shock, this equipment must only be connected to a supply mains with protective earth.
- To avoid the risk of electric shock, do not replace the power supply cord.
- The EQUIPMENT should not be used adjacent to or stacked with other equipment and that if adjacent or stacked use is necessary, the EQUIPMENT should be observed to verify normal operation in the configuration in which it will be used.
- When an examination requires X-ray irradiation to implantable or wearable electronic medical device, the operator must take proper care after referring to the Instructions for Use (and related safety information) for such implantable or wearable electronic medical devices because if a diagnostic X-ray device directly irradiates an implantable or wearable electronic medical device, it can cause sufficient electronic interference to affect the function and operation of the medical device.
 - * For reference, U.S.A. FDA published about interference with cardiac implantable electronic devices (pacemakers and implantable cardioverter defibrillators), insulin pumps, and neurostimulators on the following web site. (Updated October 2024)
Title: Electronic Medical Devices, X-ray Imaging and Radiation Therapy: What to Know and How to Prevent Damage
URL: <https://www.fda.gov/radiation-emitting-products/radiation-safety/electronic-medical-devices-x-ray-imaging-and-radiation-therapy-what-know-and-how-prevent-damage>
Note that the title and URL are subject to change without notice. Review the latest information from the FDA website as needed. <https://www.fda.gov/>
- Do not use this unit for fluoroscopic examinations.
- Judgment and caution should be used in regards to radiographs of pregnant women. The decision should be based on “clinical need of diagnostic information”.
- Do not use the wireless transmission devices listed below in the examination area; electromagnetic interference from these devices could cause this X-ray unit to operate in a random, unexpected and dangerous manner.
 1. Mobile terminals, smart devices.
 2. Wireless transmitting devices such as ham radios, walkie-talkies, and transceivers.
 3. Cell phones.
 4. Routers for intra-building paging systems, wireless LAN, cordless analogue telephones, and other electric wireless devices.
- Interference from the Veraview iX, devices listed below might malfunction or operate in a random, unexpected and dangerous manner.
 1. Electric medical devices for examination, diagnosis and treatment.
 2. Personal computers.
- The Unit must be installed in an X-ray shield location. Local regulation for radiation protection must be observed.
- The emission button must be operated in a radiation protected area.
- If the unit is not enclosed by an X-ray booth or other protective barrier, everyone except the patient must stay outside from a distance not less than 2 m from tube head during X-ray emission.
- The user must restrict access to the equipment in accordance with local regulations for radiation protection.
- The operator must not enter the X-ray beam during exposure. The residual radiation exists even behind the radiography media (film, sensor, and imaging plate).
- The patient and operator must be provided with appropriate X-ray protection gear such as lead-impregnated clothing that conforms to local regulations.
- The operator must be able to see the exposure emissions lights and hear the audible signal during operation of the equipment.
- The operator must be able to see and hear the patient during the operation of the equipment.
- Responsible organization in medical institution needs for providing means for audio and visual communication between the operator and the patient.
- Proper radiation safety precautions must be established in accordance with local, state and governmental regulations in regards to operator and patient protection. The ultimate responsibility lies with the owner/operator to ensure that the protection requirements of national and local codes are met.
- Proper infection control procedures must be established and maintained for each patient.
- Do not use multiple portable socket outlet nor extension cord for the power supply.

⚠ CAUTION

- Do not install the film processor (developer) in the same room as the unit; it could corrode the electric circuit.
- Infection control procedures must be observed when using accessories, such as film holders, X-ray tube guides, imaging plates and CCD detectors. When using accessories always follow the manufacturer's instructions on how to use the accessory and prevent cross contamination from one patient to another.
- Do not hang onto the arm or lean on it etc. This could damage the arm or cause it to come off.



- Do not place your fingers in the moving section, or the spaces in between the arm, head rest, X-ray head, and inverter box.



- Do not push the scissor arm towards the horizontal arm with excessive force; this could damage it.

Parts Identification

Parts Identification

■ R-Type (with patient's chair)

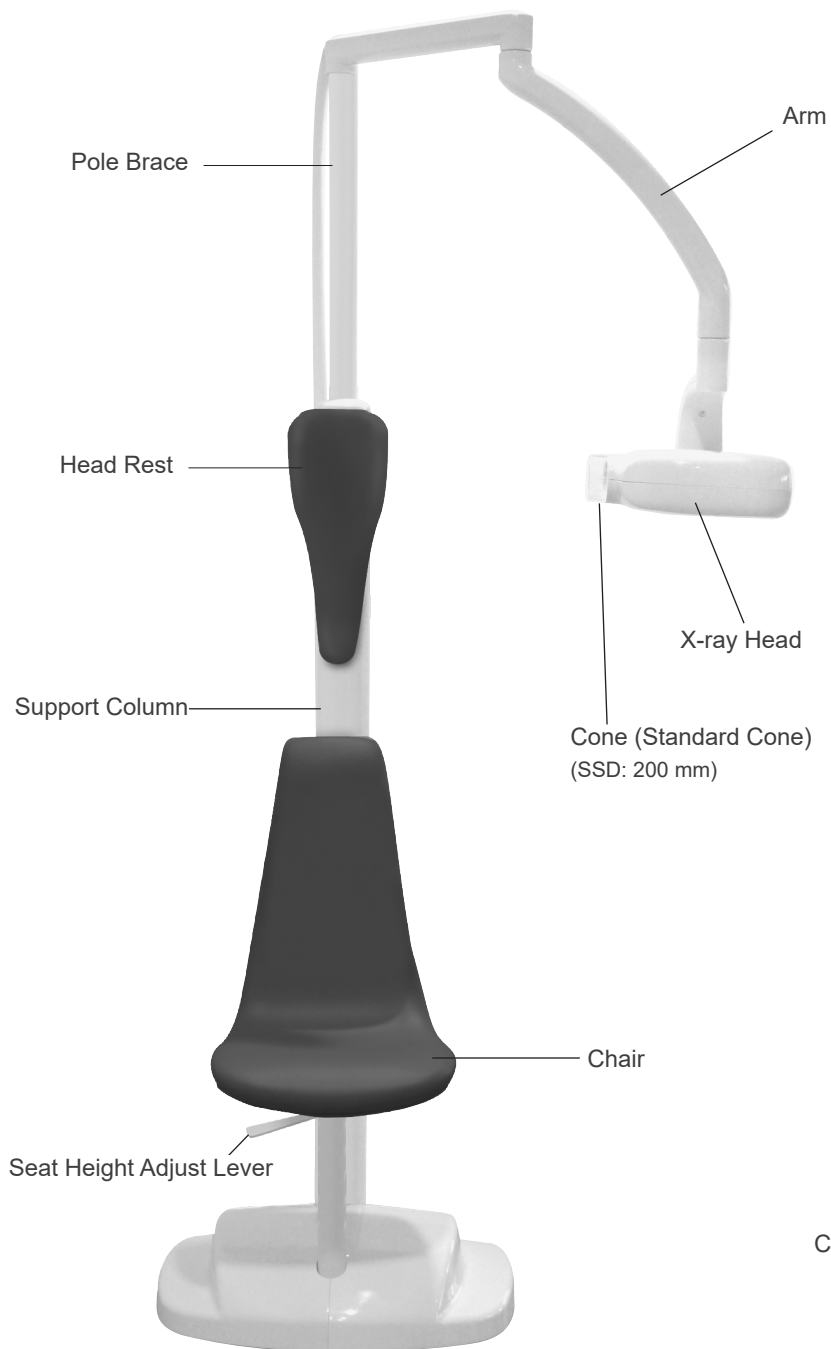

■ Control Box



Parts Identification

■ WA-Type (wall-mounted type)

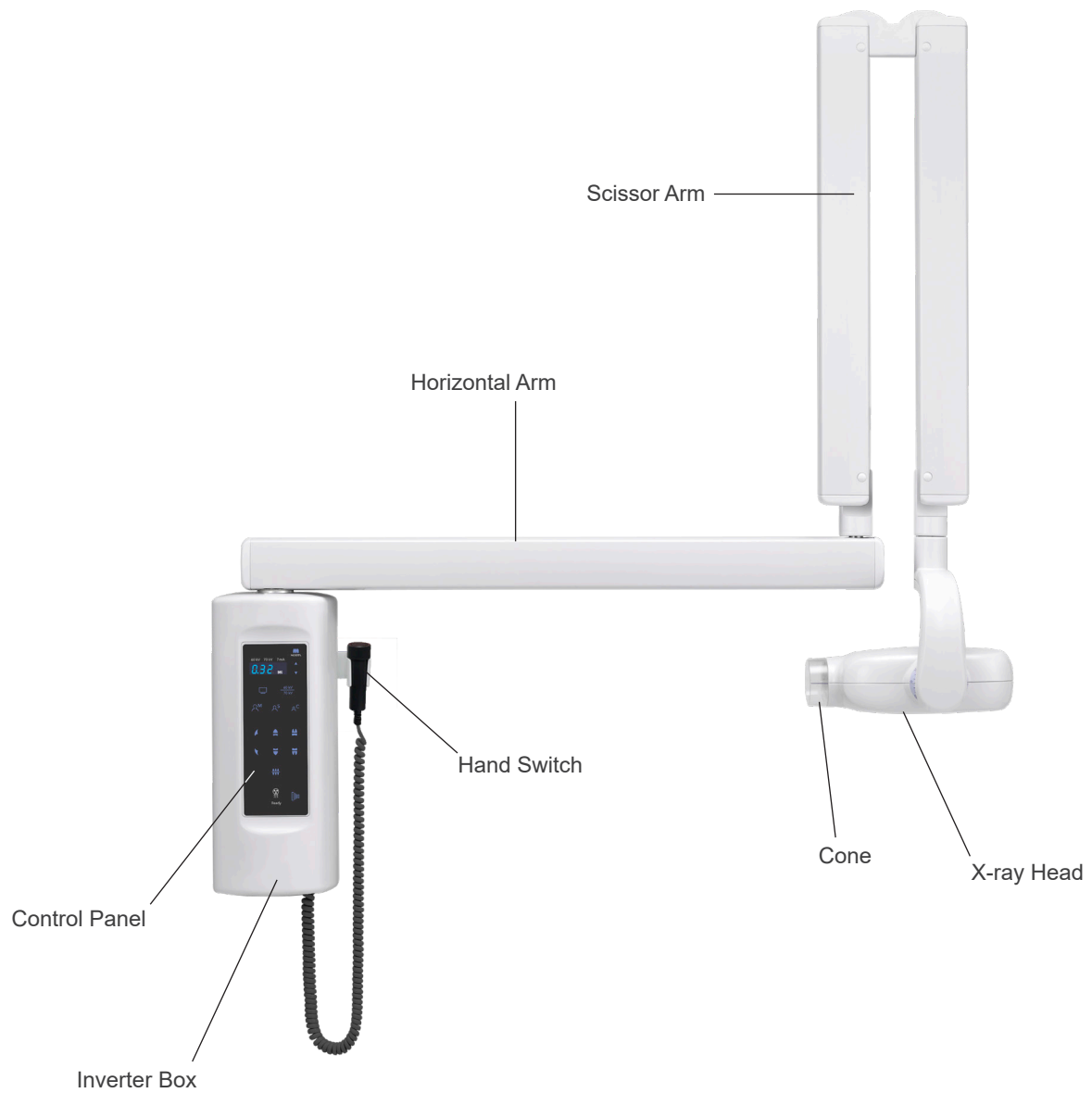

* Control Panel: There is a specification to operate remotely by Inverter box as R-Type.

Parts Identification

Control Panel

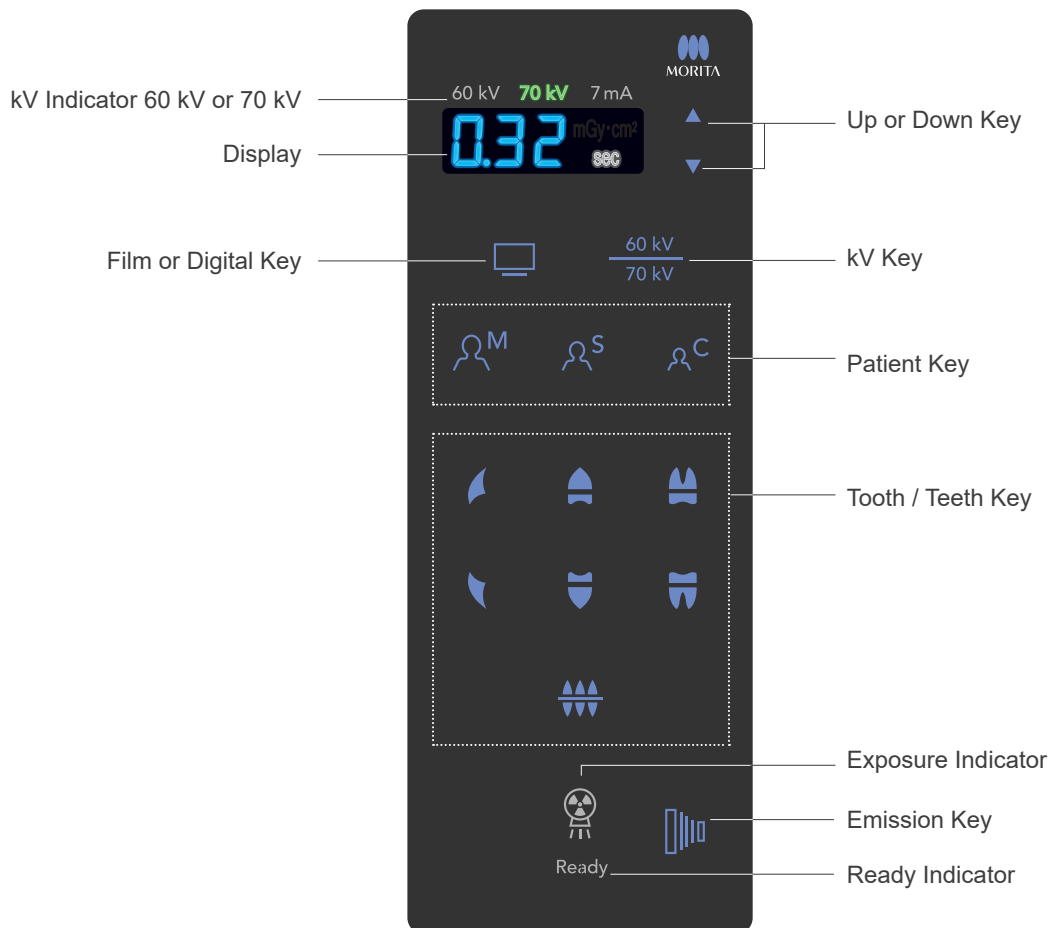

⚠ Do not press the keys and the display too hard.

Usage

* If the unit has not been used for some time, make sure it works properly before using it again.

(1) Before Use

Turn the Power Switch On

R-Type



Back of support column

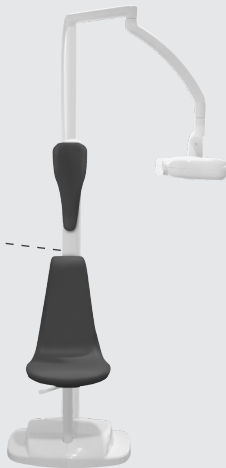

WA-Type



Bottom of the inverter box



Press the On side (-) of the switch to turn the unit on.
The timer display and the keys on the control panel will light up.

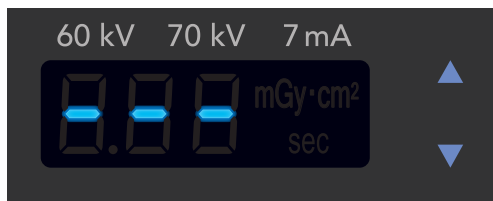

⚠ The control panel enters sleep mode if left for five minutes (default) with no operation after the unit is turned on. At this time, the timer display appears as shown at left.

To cancel sleep mode, press any key (except the Emission key) on the control panel.

WARNING

- In case of lightning, avoid the risk of electrical shock: stop using the equipment immediately and have the patient move away from it. Do not touch the equipment or the main power cord.

(2) Use

Selecting the exposure parameters

1

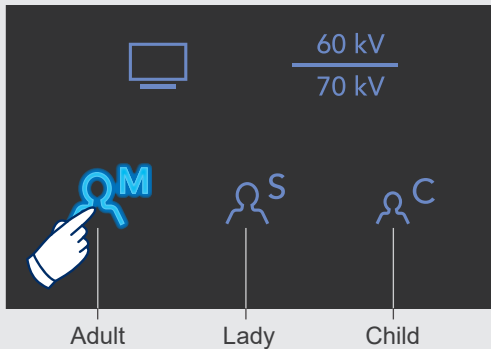

Select a Patient Type Selection key to adjust to the patient's physical build or other considerations.

2

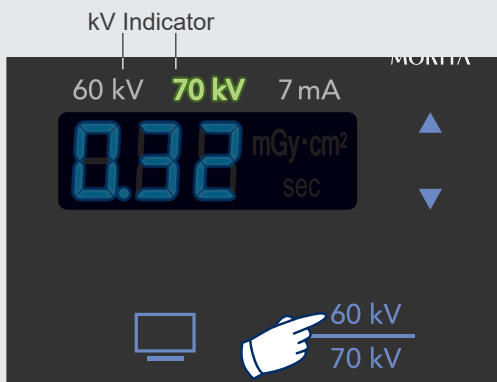

Select a kV value. Pressing the key switches between 60 kV and 70 kV.

! The value 7 mA is fixed and cannot be changed.

3

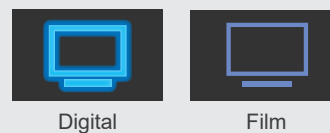
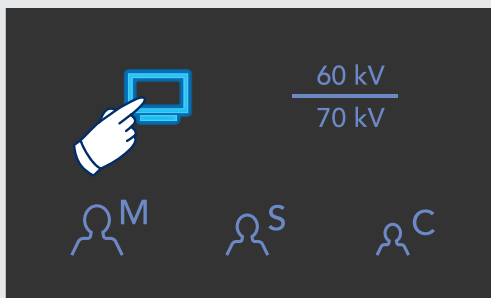

* For the timer table, refer to page 20.

Select Digital or Film. Pressing the key switches between them.

Selecting radiography conditions

4

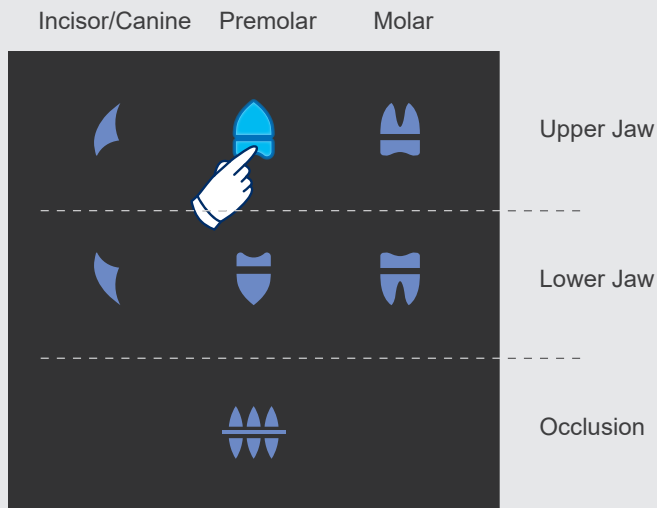

Select an area (tooth) to be radiographed.

5

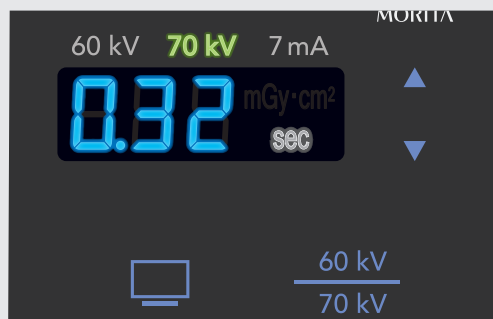

The exposure time (in seconds) will be shown on the display. The exposure time for the selected parameters will automatically appear on the display.

■ To change the exposure time

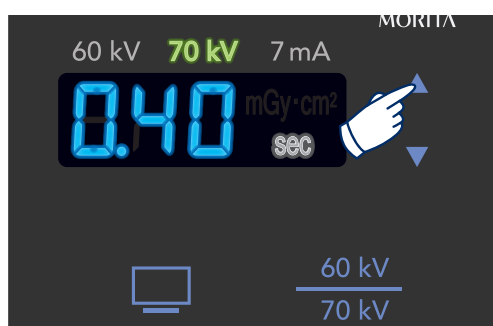

The exposure time can be manually adjusted by pressing Up or Down key.

* After changing the exposure time, press and hold the selected area (tooth) key for approximately five seconds until you hear beeps. This saves the exposure time for the radiography condition selected at the time.

ⓘ Press the up or down key to switch the number according to the timer table which is described later (*The value does not change by 0.01).

Settable numbers are any of the table numbers (00 to 14).

Positioning the patient

1



Pull up the seat adjustment lever to adjust the seat height.

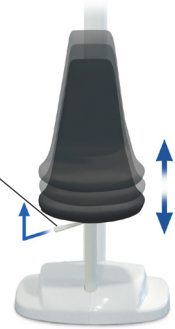

Have the patient wear an X-ray protection apron.
Set radiography media (film, sensor, and imaging plate) in the patient's mouth correctly.
Have the patient seated when R-Type is used.



- ⚠ Store radiography media in a clean, uncontaminated area.
- ⚠ Poor patient positioning may make it hard to make a correct diagnosis using the captured image.

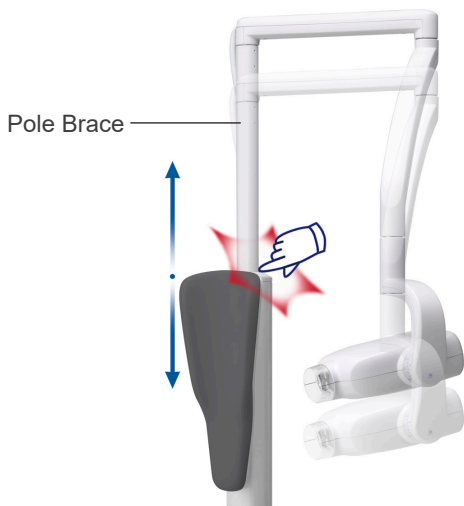

Slide the pole up or down to adjust the height of the X-ray head.



⚠ WARNING

- Infection control procedures must be observed when using accessories, such as film holders, X-ray tube guides, imaging plates and CCD detectors. When using accessories always follow the manufacturer's instructions on how to use the accessory and prevent cross contamination from one patient to another.
- When lowering the pole, do not pinch your fingers between the pole and the main support column.
- Maximum loading limit of Body Weight is 135 kg. Do not use this equipment for patients who weight more than 135 kg.

⚠ CAUTION

- Have patients remove glasses, earrings and any other accessories that might interfere with making a good exposure.
- When moving the light pole up or down or rotating the arm, do not use excessive fore, especially if the pole or arm reaches its stopper. This could damage the equipment. (R-Type)

Positioning the patient

2

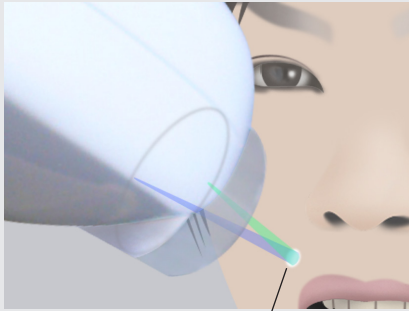

Intersection of the blue and green pointers (the center of the radiation field)

Pull the X-ray head toward the patient to direct the cone toward the radiography media in the patient's mouth so that you can adjust the exposure point and angle.

You can adjust the exposure point by taking advantage of the pointers.

⚠ When Long SSD cone (option) is attached, the pointer is inoperable.



Pointers

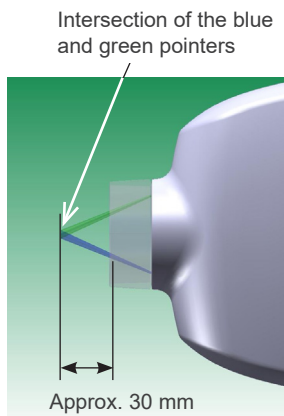

The pointer lights are turned on when the X-ray unit is turned on or when the pointer light switch is pressed. The pointer lights will be turned off automatically in one minute. The intersection of the blue and green pointers is the center of the radiation field.

⚠ WARNING

- The pointer lights may damage the eye. Do not look into the X-ray tube or the lights may enter your eye.

⚠ CAUTION

- Operate with care to avoid hitting the tube head to the wall. Otherwise the tube head might possibly be destroyed.
- Do not use the unit if the arm or tube head moves abnormally (with abnormal noise) when positioning the tube head.

Taking an exposure

1

Ask the patient not to move during the exposures.

The operator must stay outside the X-ray room or protect him/herself from exposure if staying in the room.

2

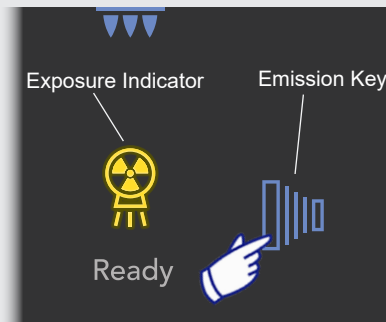
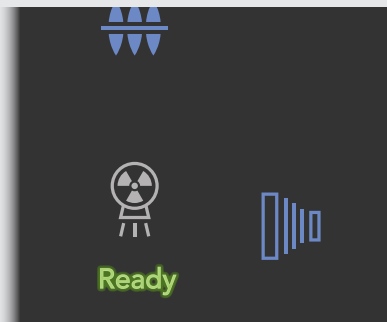

Check that the Ready indicator lights up in green.
Press the Emission button or key to take an exposure.



During exposure, the exposure buzzer is heard and the exposure indicator lights up.
Hold the Emission button or key until the exposure buzzer stops.

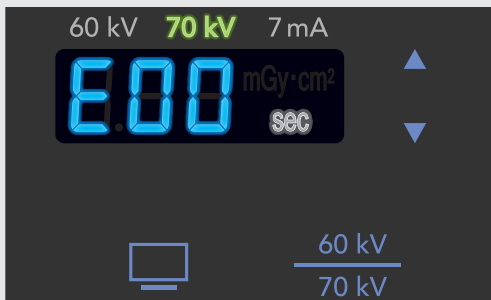

⚠ If you release the Emission button or key before exposure is completed, the radiography process is interrupted and the error message “E00” is displayed on the timer display.
To clear the message, press any key (except the Emission key) on the control panel.

⚠ WARNING

- Everyone except the patient must stay outside the X-ray room during X-ray emission. If the unit is not enclosed by an X-ray booth or other protective barrier, everyone except the patient must stay outside from a distance not less than 2 m from tube head during X-ray emission.
- When it is required to stay in the X-ray room during the radiography, the operator must wear X-ray protective clothing.
- Always monitor the patient and the unit during X-ray radiography. Should an emergency occur, release your finger from the Emission button or key to stop the unit.

⚠ CAUTION

- Hold the Emission button or key until the radiography is completed. If the Emission button or key is released before the radiography is completed, the radiography process is interrupted.
- In the event that the unit does not respond to key operation, turn off the unit and have the patient leave the room. Power the unit on again after one minute or more has elapsed after the unit was turned off.

Taking an exposure

3

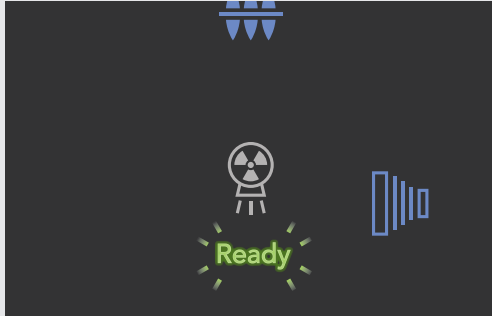

After exposure is completed, the exposure buzzer stops and the exposure indicator turns off.

In addition, the Ready indicator (green) blinks and the timer display alternately shows the exposure time taken and the Dose area product.

* For more information on Dose area products, refer to page 22.

ⓘ The unit occasionally discontinues operation for a period to protect the X-ray tube. During this time, no X-rays can be emitted. The time remaining (in seconds) until the unit is ready for use is displayed as a countdown on the timer display if the Emission button or key is pressed. The timer display alternately shows the exposure time taken and the Dose area product during the non-operating time or before pressing any radiography condition selection keys after a non-operating time.

4

Remove the radiography media from the patient's mouth.

■ Ready indicator

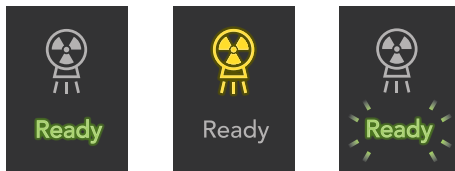

Light Green : Ready for emission
Light OFF : Currently emitting
Blink in Green : Preparing for emission

(3) After Use

Turn the Power Switch Off

After you finish radiography, turn off the power switch.



 It takes approximately 10 seconds for the timer display to turn off after the power switch is turned off.

WARNING

- Do not fail to turn the power switch off. This will avoid the risk of electric shocks, burns, or accidentally pressing a switch.

(4) User Setting

Startup settings for radiography conditions and sleep mode time

- ⓘ Before making settings, check that the Ready indicator is lit.
- ⓘ Exposures cannot be taken when you are in the setting mode.

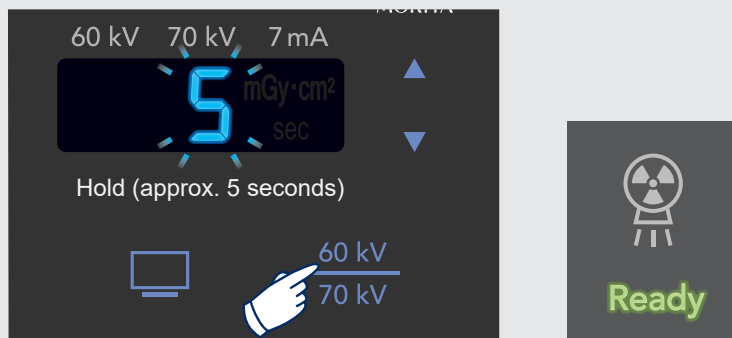

To enter the setting mode, press and hold the kV key (approximately five seconds) until you hear beeps. The timer display will show a blinking "5" (default).

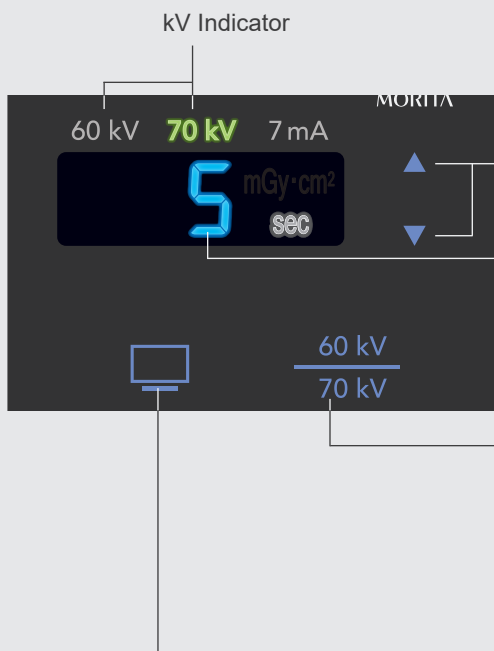

Sets the amount of time before entering sleep mode (OFF to 60 minutes).
Press the up or down key to switch the value in increments of five minutes.
* The default is 5 (minutes).

Selects 60 kV, 70 kV, or previous setting. Press this key to switch the kV indicators.
60 kV lit up: Starts with the 60 kV setting
70 kV lit up: Starts with the 70 kV setting
Both 60 kV and 70 kV lit: Starts with the setting applied at the previous usage

Selects film photo, digital photo, or previous setting. Press this key to switch the setting.
Light OFF: Starts with film radiography
Light ON : Starts with digital radiography
Blink: Starts with the setting applied at the previous usage

Startup settings for radiography conditions and sleep mode time

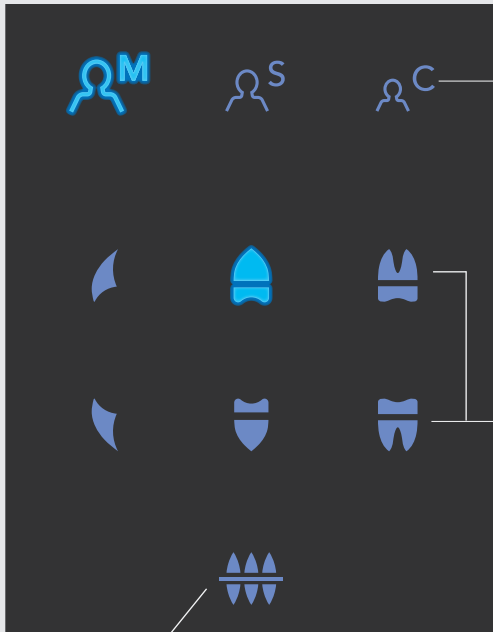

Occlusion Key

Selects Adult, Lady, Child, or previous setting.

Press the desired key.

The keys will blink if a key is pressed twice.

Single key lit: Starts in the mode selected by the lit button

All 3 keys blink: Starts with the setting applied at the previous usage

Selects a tooth type or previous setting.

Press the desired key.

All six keys blink in turn if a key is pressed twice.

Single key lit: Starts in the mode selected by the lit button

Six keys blink in turn: Starts with the setting applied at the previous usage

⚠ The Occlusion key cannot be set.



To save all settings and exit the setting mode, press and hold the Occlusion key (approximately 5 seconds).

* Hold the key until you hear beeps.

At the next startup, the unit will be configured with the saved radiography conditions.

⚠ To not save the settings, press the Occlusion key for a short time or turn off the unit.

Setting the timer table

*For the timer table data, refer to the next page.

- ⓘ Before making settings, check that the Ready indicator is lit.
- ⓘ No X-rays can be emitted when the unit is in the setting mode.

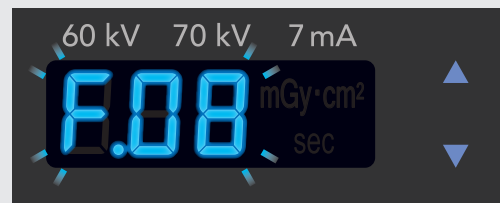
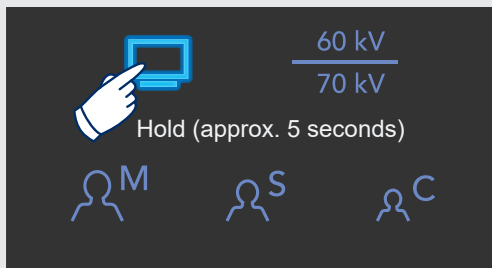

To switch to the timer table setting mode, press and hold the Film/Digital key (approximately five seconds) until you hear beeps.

The timer display will show "F. 08" * blinking (*Default for the standard cone. For the long cone, "F. 11" is shown.)

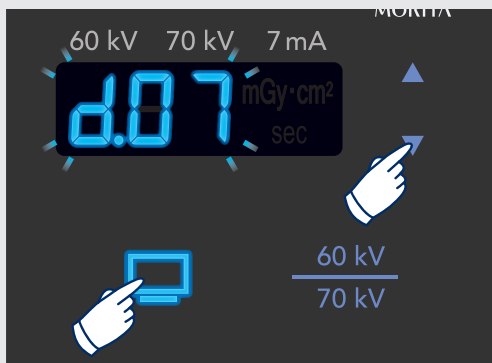

To switch to "F" (film) or "d" (digital), press the Film/Digital key.

To switch the table number (00 to 14) to set a timer table, press the up or down key.

* For recommended values, refer to page 21.

* "F. 08" is set as the default timer table for film radiography (sensitivity E), and "d. 07" is set as the default timer table for digital radiography.

To save all settings and exit the timer table setting mode, press and hold the Occlusion key (approximately 5 seconds).

* Hold the key until you hear beeps.

- ⓘ The settable numbers are any of the table numbers (00 to 14).
- ⓘ To not save the settings, press the Occlusion key for a short time or turn off the unit.

Timer table

- ⓘ The following timer table is based on the 60 kV setting with the use of the standard cone.
 When switched to 70 kV, the unit will apply and display the timer table number two smaller than a selected timer table number.
 When using the long cone, manually select the timer table number three greater than the timer table number you would normally want to choose.

		Upper incisor	Upper premolar	Upper molar	Lower incisor	Lower premolar	Lower molar	Occlusion
No. 00	Adult (M)	0.04	0.05	0.06	0.03	0.03	0.05	0.08
	Lady (S)	0.03	0.03	0.04	0.02	0.03	0.03	0.05
	Child (C)	0.02	0.03	0.03	0.01	0.02	0.03	0.04
No. 01	Adult (M)	0.05	0.06	0.08	0.03	0.04	0.06	0.10
	Lady (S)	0.03	0.04	0.05	0.02	0.03	0.04	0.06
	Child (C)	0.03	0.03	0.04	0.02	0.02	0.03	0.05
No. 02	Adult (M)	0.06	0.08	0.10	0.04	0.05	0.08	0.13
	Lady (S)	0.04	0.05	0.06	0.03	0.04	0.05	0.08
	Child (C)	0.03	0.04	0.05	0.02	0.03	0.04	0.06
No. 03	Adult (M)	0.08	0.10	0.13	0.05	0.06	0.10	0.16
	Lady (S)	0.05	0.06	0.08	0.03	0.05	0.06	0.10
	Child (C)	0.04	0.05	0.06	0.03	0.03	0.05	0.08
No. 04	Adult (M)	0.10	0.13	0.16	0.06	0.08	0.13	0.20
	Lady (S)	0.06	0.08	0.10	0.04	0.06	0.08	0.13
	Child (C)	0.05	0.06	0.08	0.03	0.04	0.06	0.10
No. 05	Adult (M)	0.13	0.16	0.20	0.08	0.10	0.16	0.25
	Lady (S)	0.08	0.10	0.13	0.05	0.08	0.10	0.16
	Child (C)	0.06	0.08	0.10	0.04	0.05	0.08	0.13
No. 06	Adult (M)	0.16	0.20	0.25	0.10	0.13	0.20	0.32
	Lady (S)	0.10	0.13	0.16	0.06	0.10	0.13	0.20
	Child (C)	0.08	0.10	0.13	0.05	0.06	0.10	0.16
No. 07	Adult (M)	0.20	0.25	0.32	0.13	0.16	0.25	0.40
	Lady (S)	0.13	0.16	0.20	0.08	0.13	0.16	0.25
	Child (C)	0.10	0.13	0.16	0.06	0.08	0.13	0.20
No. 08	Adult (M)	0.25	0.32	0.40	0.16	0.20	0.32	0.50
	Lady (S)	0.16	0.20	0.25	0.10	0.16	0.20	0.32
	Child (C)	0.13	0.16	0.20	0.08	0.10	0.16	0.25
No. 09	Adult (M)	0.32	0.40	0.50	0.20	0.25	0.40	0.63
	Lady (S)	0.20	0.25	0.32	0.13	0.20	0.25	0.40
	Child (C)	0.16	0.20	0.25	0.10	0.13	0.20	0.32

(Unit: sec.)

Timer table

		Upper incisor	Upper premolar	Upper molar	Lower incisor	Lower premolar	Lower molar	Occlusion
No. 10	Adult (M)	0.40	0.50	0.63	0.25	0.32	0.50	0.80
	Lady (S)	0.25	0.32	0.40	0.16	0.25	0.32	0.50
	Child (C)	0.20	0.25	0.32	0.13	0.16	0.25	0.40
No. 11	Adult (M)	0.50	0.63	0.80	0.32	0.40	0.63	1.00
	Lady (S)	0.32	0.40	0.50	0.20	0.32	0.40	0.63
	Child (C)	0.25	0.32	0.40	0.16	0.20	0.32	0.50
No. 12	Adult (M)	0.63	0.80	1.00	0.40	0.50	0.80	1.25
	Lady (S)	0.40	0.50	0.63	0.25	0.40	0.50	0.80
	Child (C)	0.32	0.40	0.50	0.20	0.25	0.40	0.63
No. 13	Adult (M)	0.80	1.00	1.25	0.50	0.63	1.00	1.60
	Lady (S)	0.50	0.63	0.80	0.32	0.50	0.63	1.00
	Child (C)	0.40	0.50	0.63	0.25	0.32	0.50	0.80
No. 14	Adult (M)	1.00	1.25	1.60	0.63	0.80	1.25	2.00
	Lady (S)	0.63	0.80	1.00	0.40	0.63	0.80	1.25
	Child (C)	0.50	0.63	0.80	0.32	0.40	0.63	1.00

(Unit: sec.)

Recommended values (*For 60 kV)

Radiography condition	Timer table (display)	
	Standard cone	Long cone
Film (Sensitivity D)	No. 11 (F. 11)	No. 14 (F. 14)
Film (Sensitivity E)	No. 08 (F. 08)	No. 11 (F. 11)
Film (Sensitivity F)	No. 05 (F. 05)	No. 08 (F. 08)
Digital (IP)	No. 07 (d. 07)	No. 10 (d. 10)

Dose area product

The Dose area product displayed is the multiplication product of the air kerma end and the size of the radiation field at the cone. These values are typical values and are not the measured Dose area products for each X-ray exposure. In addition, these values differ between when the standard cone is used and when the long cone is used.

The air kerma is calculated by divided the Dose area product by the X-ray field size of diameter 58 mm.

The dosimeter to check and maintain the accuracy of the Dose area product indications shall be calibrated at the appropriate energy.

Accuracy: Display value $\pm 50\%$



* You can check the factory-set defaults as follows:

1. After checking that the Ready indicator is lit, press and hold the Lady key (approximately five seconds).



Standard Cone

Long Cone

2. Beeps will be heard and the current settings will be displayed on the timer display ("SC" or "LC" can be switched using the up or down key).

3. To save the settings, press and hold the Occlusion key (approximately 5 seconds).

(*Hold the key until you hear beeps. To not save the settings, press the Occlusion key for a short time or turn off the unit.)



The dose area product is not affected by the SSD (Source Skin Distance) but;

- Air kerma (dose) is attenuated by inverse square of the SSD ratio.
- The radiation field diameter increases in proportion to the SSD ratio.
- The size of the radiation field (area) increases in proportion to the square of the SSD ratio.

Maintenance, Parts Replacement, and Storage

Hygiene Plan Guidebook

A reference guidebook of hygiene information about our products is available. Scan the following QR code and visit our website.



In order to view PDF documents, you will need the free Adobe Acrobat Reader distributed by Adobe Inc. Download the latest version via the Adobe website. PDF documents may not be displayed correctly using previous versions.

(1) Maintenance (Cleaning and Disinfection)

Always turn off the Power switch before performing regular maintenance.



Parts to be operated for each patient (i.e., Control Panel, Hand Switch, X-ray Head, Arm) wipe with approved disinfectant once a day or when visibly contaminated.

■ Disinfection procedure

If visibly contaminated, wipe with approved disinfectant until contamination is removed, then disinfect. The surface to be disinfected must be exposed to disinfectant for a specified period of time to achieve the disinfecting effect. Follow the product information of the disinfectant manufacturer.

Clean other exterior surfaces regularly.

⚠ WARNING

- Do not fail to turn off the Power switch. This will avoid the risk of electric shocks, burns, or accidentally pressing a switch.
- When disinfecting with approved disinfectants, take care that none of it seeps inside the unit. This could damage mechanical parts.

⚠ CAUTION

- Do not use acidic or ozonated water. These may cause damage to this device (e.g., plastic and rubber components).
- Do not use ozone gas or ultraviolet light to sanitize or disinfect the clinic. These may cause damage to this device (e.g., plastic and rubber components).

- ⚠ Wear gloves when cleaning and disinfecting.
- ⚠ The disinfectant must be soaked in a wiping cloth before use. The disinfectant should never be applied directly on the surface to be disinfected. A microfiber cloth is recommended for better wiping performance.
- ⚠ Visually check the surface to be disinfected, and if cracks or discoloration occur, change the disinfectant and replace or repair the necessary parts.
- ⚠ Never use alkaline or acidic solutions, cresol soap, or other chemical solutions to clean outer surfaces. These can cause discoloration and material degradation.
Use only ethanol (70 vol% to 80 vol%), neutral detergent, or cleaning detergent supplied with the equipment (if supplied with the equipment).
- ⚠ Use ethanol (70 vol% to 80 vol%) to immediately wipe off any water, detergent or other chemicals that get on the outer surfaces.
- ⚠ The cone cannot be autoclaved.

■ Approved disinfectants

Ethanol (70 vol% to 80 vol%), if it is not possible to obtain use one of the disinfectants listed below; do not use any other type of disinfectant.

- DÜRR DENTAL's FD 322 quick disinfectant
- DÜRR DENTAL's FD 333 forte quick-action disinfection
- DÜRR DENTAL's FD 366 sensitive disinfection of sensitive surface
- Disinfect synthetic leather parts such as head rest and chair seats using ethanol(70 vol% to 80 vol%) or FD366.

(2) Replacement Parts

- * Replace the parts as necessary depending on degree of wear and length of use.
- * Order parts from your local dealer or J. MORITA OFFICE.
- * Fuses F1 and F2 for R-Type located on Filter PCB.
- * Fuses F1 for WA-Type located on Filter PCB.

Code No.	Description	Rating	Type	Qu.
6112473	Main Fuse (For EX-2)	F10 A 250 V	Fast-acting, High Breaking Capacity, Size: 5 × 20 mm	1



- * The fuse must be replaced by a qualified serviceman.
- * Fuse shall be certified according to IEC127 or 241, or manufactured in proportion to IEC127 or 241.

(3) Optional Parts

Code No.	Description	Rating	Type	Qu.
6032129	Long SSD cone	-	V080CL	1

(4) Storage

- * For transport and storage conditions, refer to page 32.
- Do not expose to direct sunlight frequently or for long times.
- If the unit has not been used for a long time, make sure it works properly before using.

WARNING

- The Filter PCB remains live even if the Power Switch is turned off. Unplug the Power Cord or turn off the Power Breaker in the Power Distribution Panel before servicing.

Maintenance and Inspection

Regular Inspection

- Maintenance and inspection are generally considered to be the duty and obligation of the user, but if, for some reason, the user is unable to carry out these duties, they may be performed by the accredited service personnel. Contact your local dealer or J. MORITA OFFICE for details.
 - Replace the parts listed in the Parts Lists as necessary depending on degree of wear and length of use.
 - This apparatus should be inspected every 6 months in accordance with the following maintenance and inspection items.
 - The inspection items marked * may only be performed by the service personnel for further preventive inspection and maintenance during the life of the device.
- * Repairs and maintenance must be carried out in accordance with the specified procedures and using genuine parts designated by J. MORITA MFG. CORP.
J. MORITA MFG. CORP. will not be responsible for any accidents, product damage, or bodily injury resulting from failure to use genuine parts or to follow the specified procedures.

Maintenance and Inspection Items

1. Power Supply Voltage
 - * Use a digital or analog tester to measure the unit's power supply. The result must be within the range below.
 - Type EX-2: 220 V – 240 V \pm 10%
2. Ground connection
 - Visually inspect the ground connection to make sure it is securely and properly connected.
3. Fixing state of unit
 - R-Type: Make sure that the Base is firmly fixed to the floor, and not be wobbly.
 - WA-Type: Make sure that the Inverter box is fixed to the wall, and not be wobbly.
4. Arm and Tube head action
 - Operate Arm and Tube head to confirm backlash. Check whether it stops at the intended stop position.
 - Confirm the arm moves normally (without abnormal noise).
 - Confirm the mechanical stopper. Arm and Head shall not over the intended range of movement.
5. Head/ Cone
 - Check for oil leaks, if the insulation oil filled in the tube head assembly in X-ray Head from the outside of the enclosure.
 - * Oil leak check from the tube head assembly inside the enclosure may only be done by the accredited service personnel.
 - Check the cone has no damages. Make sure that cone is securely attached.
6. Chair and Head rest (R-Type)
 - Confirm seat height is adjusted by lever. Check chair and head rest do not be wobbly.
7. Electrical circuitry
 - Make sure all wiring and connections are intact.
 - * Inspection of the wiring inside the enclosures may only be done by the accredited service personnel.
8. Power switch
 - Make sure main power can operate On/Off by power switch. Check power lamp lights when power switch is on.
9. Control Panel
 - Check all keys, Film or Digital key, kV selection key, Patient selection key, Tooth/teeth selection key and Up/down key, can operate properly, and confirm the display is switching correctly.
10. X-ray emission
 - Confirm that X-ray is emitted by hold down the Emission key/Emission button, and an audible signal will sound and exposure indicator will light up, and the audible signal and exposure indicator automatically stop when emission is completed
 - * Check the actual kV and mA values. The kV and mA values are within the range below.
 - kV: Setting value \pm 10%, mA: 7 mA \pm 10%
11. Emergency stop
 - If you release Emission key or Emission button during the X-ray emission, make sure exposure is stopped and error message "E00" is displayed.
12. Pointer
 - When turns on the device, the pointer lights and it will be turned off automatically in one minute.
 - The pointer lights up again by pressing the switch in back of the tube head.
13. X-ray field
 - Check predetermined X-ray field Size is in the edge of Cone.

* For repairs contact your local dealer or J. MORITA OFFICE.

Service Life

Service life refers to the standard period the unit or individual components can be expected to be usable as long as inspection and maintenance procedures specified by J. MORITA MFG. CORP. are followed.

Component Service Life List refers to components that can be expected to wear out, degrade or break depending on frequency and conditions of usage, which greatly affects how long these components retain their performance standards.

The product warranty is good for 3 years after delivery.

The components on the Component Service Life List that are noted "Yes" are critical for safety. These components must be inspected and replaced or have appropriate maintenance performed as necessary without fail before their standard service life expires.

The user must pay for parts and repairs that are performed after the warranty expires or the part has passed its specified service life. However, if a maintenance contract has been agreed to, this will depend on the contents of that contract.

For details concerning regular inspection and parts replacements, contact your local dealer or J. MORITA OFFICE.

* Repairs and maintenance must be carried out in accordance with the specified procedures and using genuine parts designated by J. MORITA MFG. CORP.

J. MORITA MFG. CORP. will not be responsible for any accidents, product damage, or bodily injury resulting from failure to use genuine parts or to follow the specified procedures.

■ Component Service Life List

Components	Standard Service Life	Critical Safety	Component Remarks
Moving Parts (for Arm and Lift)	30,000 exposures or 4 years whichever comes first.	Yes	Including cables, bearings, etc.
X-ray Tube ^{*1}	15,000 exposures	N/A	
High Voltage Unit	3 years	N/A	
Printed Circuit Boards	4 years	Yes	
Touch Panel, Operation Switches	3 years	N/A	
Chair, Head Rest	6 years	N/A	Excluding stains and scratches on the surface.

^{*1} The service life of the X-ray tube depends on the number and length of exposures it is used for as well as the output (tube voltage and current) and the time between exposures. Of these factors, the most critical is the number of exposures which degrades the anode. As the anode gradually degrades, stable output is lost, and the circuit protection system detects errors and terminates X-ray emission.

■ Service

J. MORITA products may be repaired and serviced by:

- The technicians of J. MORITA's subsidiaries all over the world.
- Technicians employed by authorized J. MORITA dealers and specially trained by J. MORITA.
- Independent technicians specially trained and authorized by J. MORITA.

The circuit diagrams, component parts lists, descriptions, calibration instructions, or other information will be available on request, only for the service personnel authorized by J. MORITA MFG. CORP. to repair those parts.

Troubleshooting

If the equipment does not seem to be working properly, the user should first try to inspect and adjust it himself.

- * If the user is unable to inspect the equipment himself or if the equipment fails to work properly after being adjusted or after parts are replaced, contact your local dealer or J. MORITA OFFICE.
- * The inside parts of the equipment are charged with high voltage. Do not attempt to perform maintenance or adjustment that is not described in the troubleshooting table.
- * If an accident occurs, the equipment must not be used until repairs have been completed by a qualified and trained technician provided by the manufacturer.

Problem	Check Points	Response
No power when power switch is turned on.	<ul style="list-style-type: none"> • No power supply 	<ul style="list-style-type: none"> • Check the breaker on the distribution panel.
Cannot expose X-ray even if emission key/ emission button is pushed.	<ul style="list-style-type: none"> • Ready Indicator on the Control Panel is flashing. 	<ul style="list-style-type: none"> • Downtime until next emission operation. Wait until Ready Indicator lights up.
Beep sounds and setting value of exposure time will be set 2.0 sec. or 0.01 sec.	<ul style="list-style-type: none"> • Turn off the power supply. After all LEDs on the control panel are turned off, turn on the power supply. (Abnormality of software or breakdown of control panel's board.) 	
Pole goes down by itself.	<ul style="list-style-type: none"> • Tighten the screw in the back of the support column. Replace the screw and use the unit without the spacer. (Do not use the unit this was too long; it could be damaged. Have it repaired as soon as possible.) 	

■ Error Numbers

- * Check the list below if an error number appears in the display on the control panel. If other error No. is shown, turned the unit off, wait 1 minute, and then turn it on again
- * Contact your local dealer or J. MORITA OFFICE if the apparatus does not work normally even after performing the steps recommended below.

Error No.	Possible Cause	Remedy
E00	Emission key/ emission button is released before the exposure end	To clear the message, press any key on the control panel (except the Emission key). Hold the emission key/ emission button down until the exposure is completed.
E05	Abnormal Head Temperature	The internal temperature of the head is out of the range. If the head overheats due to repeated use, turn the unit off and wait for it to cool down. If the ambient temperature is low, heat the room and wait for the unit to warm up. Operating Ambient Temperature: +10°C to +40°C
E09	Inverter overheated.	It is the overheating of the inverter due to repeated use. Turn the unit off and wait for it to cool down.

Technical Specifications

Specifications

[Specifications may be changed without notice due to improvements.]

Model V080 Type EX-2

This unit is X-ray generator which includes X-ray source assembly and high-voltage generator.

Protection against Electric Shock	Class I, Type B
Protection against Ingress of Liquids	IPX0
Operating Altitude	3,000 m (max.)
Pollution Degree	2
Overvoltage Category	II
Disinfection Methods	By wiping with Ethanol (70 vol% to 80 vol%).
Mode of Operation	Non-continuous operation
Type B Applied Part	Head rest (no conductive connection to patients)

Intended Use

Model V080 is a Dental X-ray unit using with an intra-oral X-ray image receptor. Model V080 is used for dental radiographic examination and diagnosis of teeth, jaw and oral structure by exposing an X-ray image receptor to ionizing radiation.

To obtain diagnostic images, an appropriate imaging receptor shall be used with this device.

- CCD/CMOS type receptor: Detector line pair resolution 5 lp/mm or more, low contrast resolution diameter 1.0 mm or more.
- Imaging Plate type receptor: Scan resolution 5 lp/mm or more, low contrast resolution diameter 1.0 mm or more.
- Film: ISO speed of D or higher. E or F recommended.

For the European market, the receptor shall bear the CE marking.

X-ray Tube

Manufacturer / Model	Toshiba or Canon Electron Tubes & Devices / D-0711SB
Focal Spot	0.7 (IEC 60336)
Target Angle	16 degrees
Target Material	Tungsten
Inherent Filtration	At least 1.0 mmAl
Nominal Anode Input Power	940 W (1 sec.)
Maximum Anode Heat Content	7 kJ (10 kHU)
Nominal Tube Voltage	70 kV
Circuit (Center-Grounded)	Constant Potential (DC)
Maximum Filament Current	3.0 A
Filament Voltage	3.0 V – 3.7 V (At max. Filament Current 3.0 A)
Filament Frequency Limits	0 kHz – 20 kHz

Specifications

Generator/X-ray Head Assembly

Model	V080
Operating Tube Potential	60/70 kV (accuracy : setting values $\pm 10\%$)
Operating Tube Current	7 mA fixed (accuracy : $\pm 10\%$)
Reproducibility of Air Kerma	Coefficient of variation max. 0.05
Maximum Output Power	490 W (70 kV, 7 mA, 0.1 sec.)
Total Filtration	Min. 2.3 mmAl, 70 kV/HVL 3.1 mm. (Fixed added filter; minimum 1.3 mmAl, X-ray tube filtration; 1.0 mmAl)
Beam Quality	HVL minimum 1.5 mmAl at 70 kV
Protective Shielding	0.3 mm Pb or equivalent
Duty Cycle	1:29 (70 kV, 7 mA, for example 2 sec. exposure per 58 seconds cool-down period*) * The maximum exposure time is 2 sec. * The minimum interval is limited to 15 seconds to protect the hardware including the X-ray tube.
Filament	Preheated
Rectification	Direct Current
Cooling	Oil cooling
Maximum Heat Unit of X-ray Head	62.8 kJ (1 HU=1.35 Joule, 1 J = 1 Ws)
Maximum continues input	4.9 W
Leakage Radiation	Max. 0.25 mGy/h at 1 m
Source Skin Distance (SSD)	200 mm (Standard cone) 300 mm (Long cone) (Option)
X-ray Field Size	Max. 60 mm diam. at the end plane of the cone
Reference Axis	Runs axially with the cone
Weight of X-ray Head	Approximately 3.5 kg
Outer Dimension of X-ray Head	Approximately 280 × 220 × 92 mm (Standard cone) Approximately 380 × 220 × 92 mm (Long cone)
Max. Temperature of the Cone	Approximately +48°C at the ambient temperature of +40°C.

Irradiation Time Range

0.01 to 2.0 sec. (series R'10 IEC60601-1-3: 2008 Annex B)	
Accuracy	Setting value $\pm 5\%$ or ± 20 ms
Minimum mAs	0.07 mAs

Specifications

Power Requirements

Rated Nominal Voltage	AC 220 – 240 V, 50 – 60 Hz single phase *WA-Type: Permanently installation *R-Type: Plug-connection
Fuse at the Distribution Panel	16 A, slow
Power Consumption	Max. 1.9 kVA (radiation) Max. 0.1 kVA (stand by)
Power Line Resistance	Max. 1 Ohm

Leakage Technique Factors

70 kV, 840 mAs/h (70 kV, 7 mA, duty cycle 1:29, for example 2 sec. exposure per 58 seconds cool-down period)

Measurement Bases

The kV is: Actual X-radiation is monitored by Non Invasive Evaluator of Radiation Output. The mA is measured by monitoring current in the HT return line, which equals the tube current.

Exposure time: Starting point of exposure is determined at the time when the kV value reaches to 75% of average kV value.

Termination of exposure is determined at the time when the kV value decreases to 75% of average kV value.

Signal Output Part

Specification: This signal output is short only when the equipment is in Ready state.

- Rating: AC 24 V, 1 A / DC 24 V, 250 mA
- Location: TB1 on the INVERTER PCB
- Only use medical electrical equipment complying IEC60601-1 or GB9706.1 within the patient environment.
- Other non medical electrical equipment complying other safety standards relevant to the equipment may be used outside the patient environment. In this case any equipment in which protection against electric shock relies only on basic insulation shall not be used.
- Do not connect any equipment exceed the rated capacity to the Ready OUT terminal.
- Over current protection is not equipped. Prepare as needed.
- Single wire recommended. In case of twisted wire, the wire end shall be tidily collected up.
- Double insulated wire of AWG22-16 for single wire or AWG24-16 for twisted wire required.
- Stripped length shall be 10 - 11 mm, inserted completely to the terminal block.

Specifications

Mechanical Parameters

Weight R-Type: Approximately 33 kg (net)
 WA-Type: Approximately 25 kg (net)

Outer Dimensions

Maximum loading limit of Body Weight: 135 kg

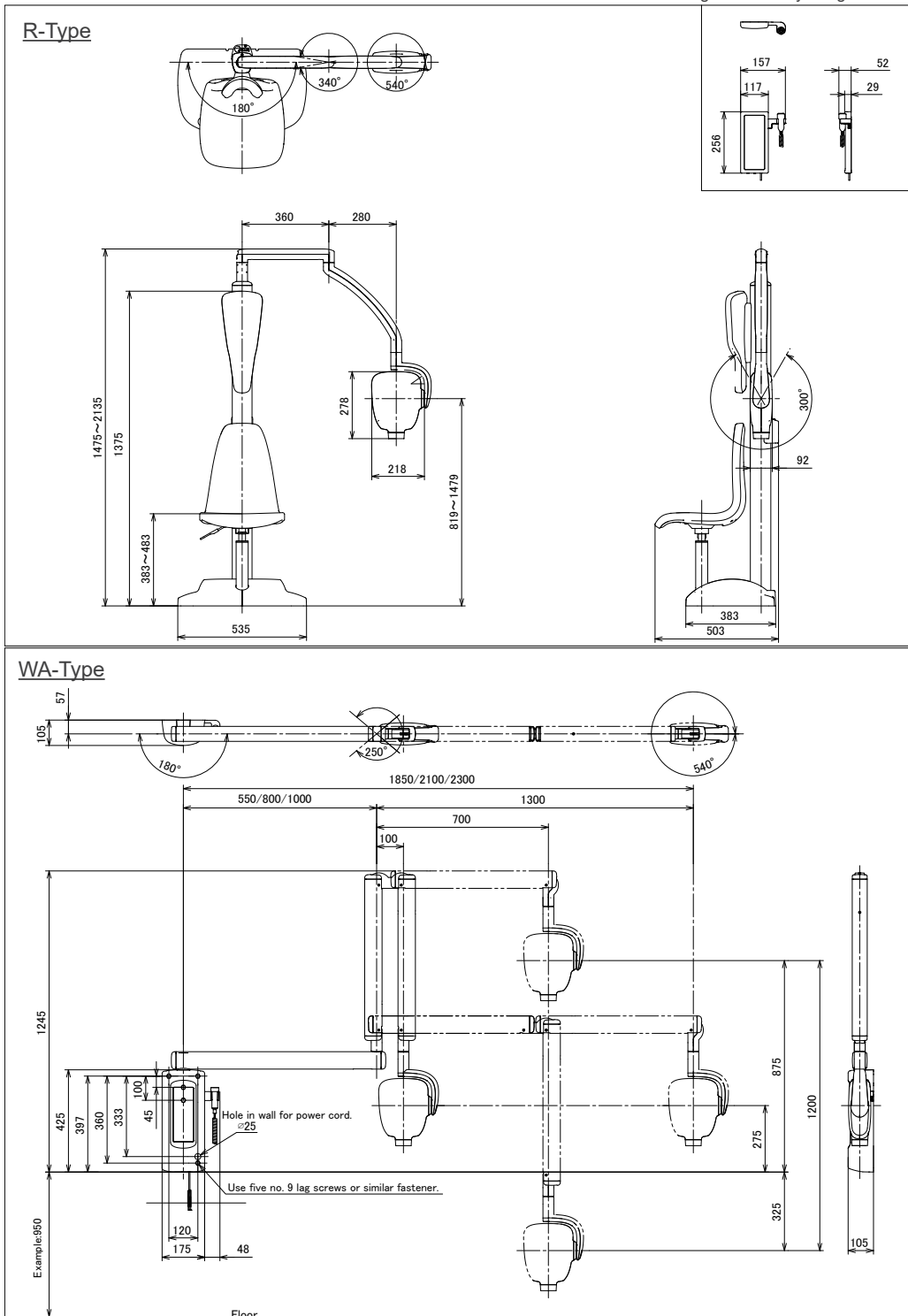

Specifications

Reference Axis

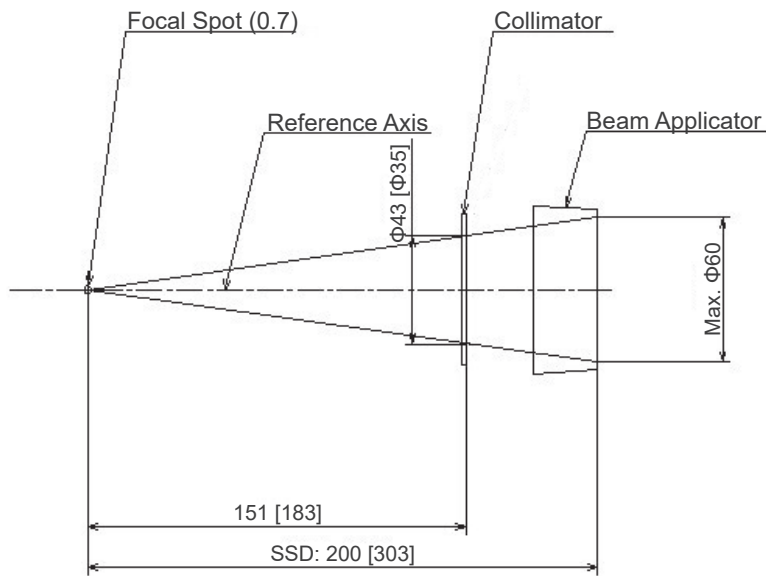

Environmental Data

Operating Conditions

Ambient Temperature	+10°C to +40°C
Humidity	30% to 75% (without condensation)
Atmospheric Pressure	70 kPa to 106 kPa

Transportation and Storage Conditions

Ambient Temperature	-10°C to +50°C
Humidity	5% to 85% (without condensation)
Atmospheric Pressure	50 kPa to 106 kPa

Original Language

English

Disposal

The package should be recycled. Metal parts of the equipment are disposed as scrap metal. Synthetic materials, electrical components, and printed circuit boards are disposed as electrical scrap. Material must be disposed according to the relevant national legal regulations. Consult specialized disposal companies for this purpose. Please inquire of the local city/community administrations concerning local disposal companies.



This symbol indicates that the waste of electrical and electronic equipment must not be disposed as unsorted municipal waste and must be collected separately. Contact your local dealer or J. MORITA OFFICE for details.

Specifications

Tube Housing Assembly Heating / Cooling Curve

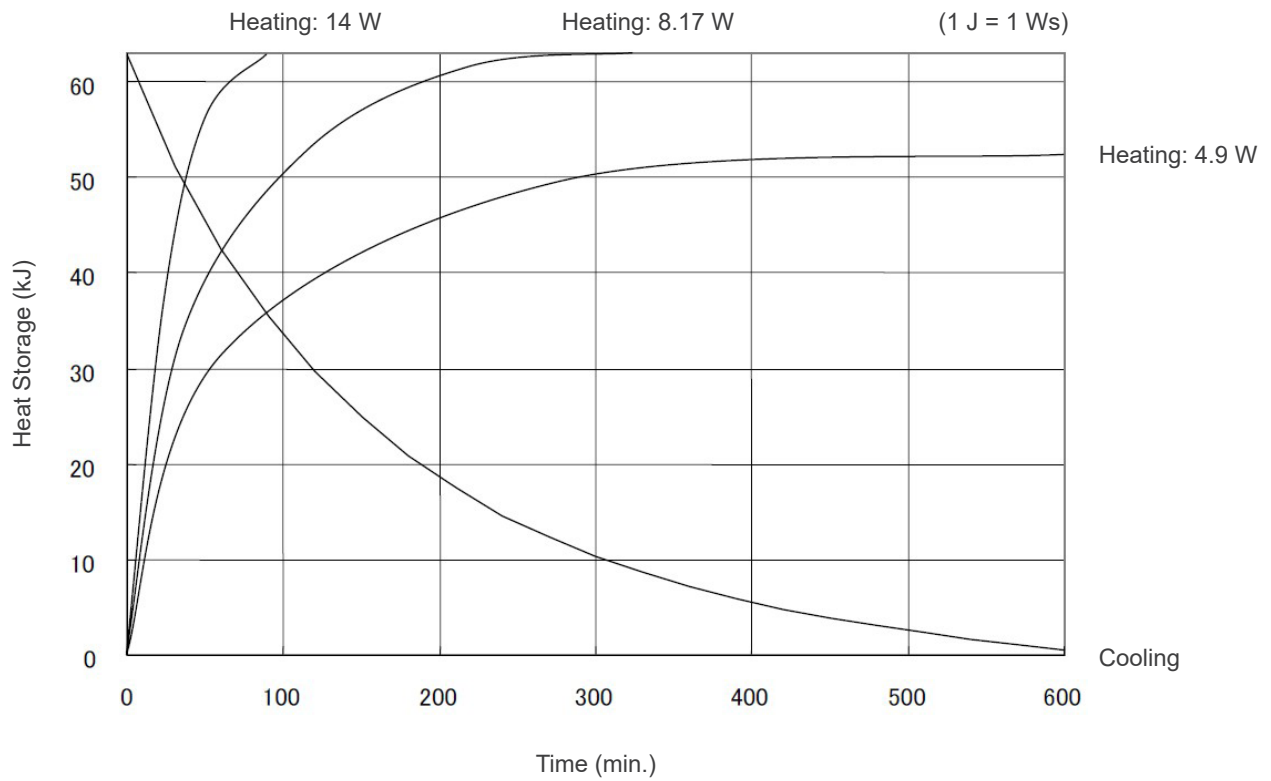

Specifications

Tube Rating Chart

D-0711SB

Maximum Rating Charts (Absolute maximum rating charts)

Constant Potential High-Voltage Generator
Nominal Focal Spot Value: 0.7

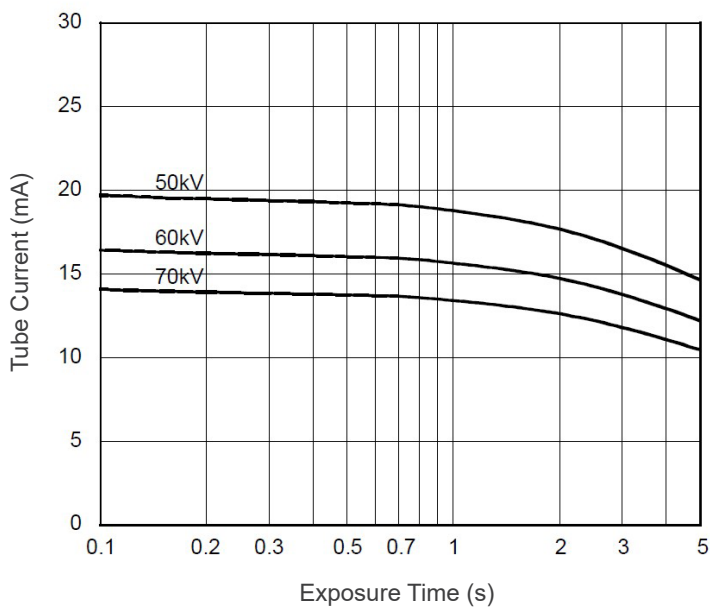

Anode Heating / Cooling Curve

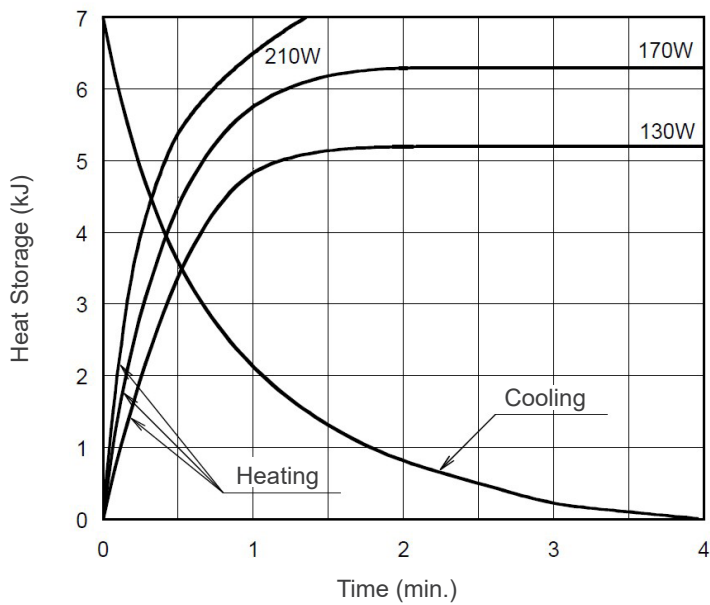

Symbols and Markings

* Some symbols may not be used.

R-Type

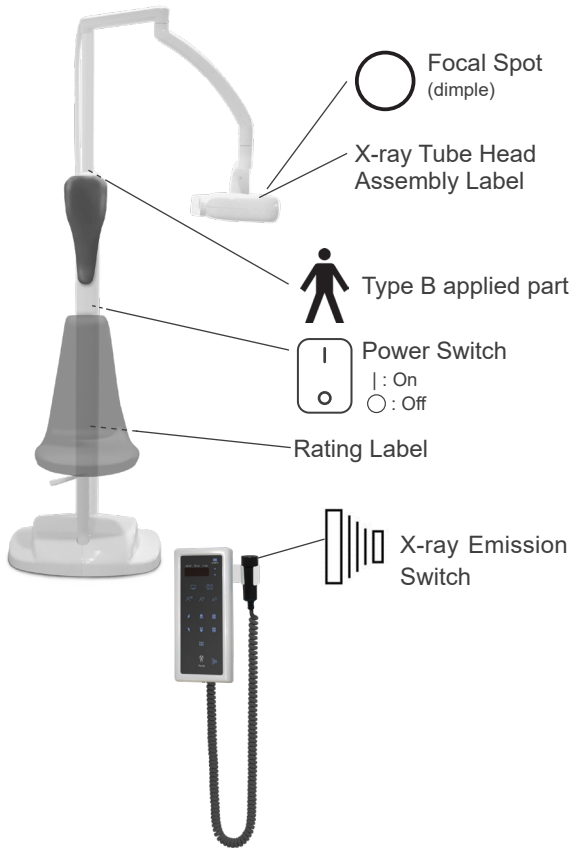

WA-Type

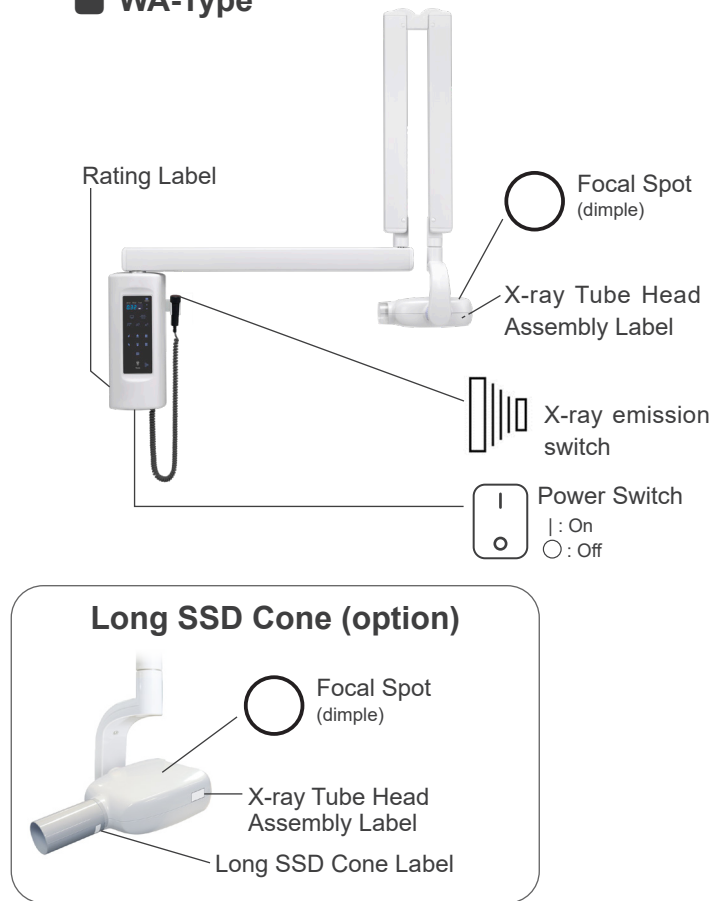

Package



This way up



Keep away from rain



Humidity limitation



Fragile



Temperature limitation



Atmospheric pressure limitation

Rx Only

Prescription Device

CAUTION: Federal law restricts this device to sale by or on the order of a dentist and a licensed healthcare practitioner. (Valid only for U.S.A.)

QTY.



Packaging unit



Importer



Distributor

CH REP

Authorized representative in Switzerland

12-3-4-5-6789012

Registration number of medical device in Thailand (The 12-digit sample number shown is for demonstration purposes only.)

USA

Country or region

EU

















(Country Names: Conforming to the ISO 3166-1 alpha-3 codes and EU for European Union)

(Examples)

Description noted next to the code is an indication that conforms to the regulations valid only for the relevant country or region.

Symbols and Markings

Rating Label, X-ray Tube Head Assembly Label, Long SSD Cone Label (option), and Instructions for Use

 Serial number	 Manufacturer	 Date of manufacture
 Medical device	 Unique device identifier	 GS1 DataMatrix
 Refer to instructions for use	 Alternating current	 Country of manufacture (Japan) Date of manufacture
 Model and/or type number	 Consult instructions for use or electronic instructions for use	
 Country or region (Country Names: Conforming to the ISO 3166-1 alpha-3 codes and EU for European Union)		 CE(0197) marking (Valid only for EU) Conforms with the European Directive, 93/42/EEC.
 (Examples) Description noted next to the code is an indication that conforms to the regulations valid only for the relevant country or region.		 0197 CE marking (Valid only for EU) Conforms with the European Directive, 2011/65/EU.
 Marking of electrical equipment in accordance with the European Directive 2012/19/EU (WEEE) (Valid only for EU)		 EU authorized representative under the European Directive 93/42/EEC (Valid only for EU)

Indicated Items on the Rating Label, X-ray Tube Head Assembly Label, and Long SSD Cone Label (option)

- * For details, refer to "Technical Specifications" (p. 28).
- * Some symbols described in this page may be included.

Rating Label

Model: Model code
Type: Type
Input: Input voltage and frequency
Loading: Input power in operation
Standby: Input power on standby
Tube Voltage: Max. X-ray tube voltage
Tube Current: Max. X-ray tube current
Exposure Time: Max. X-ray exposure time
Nom. Focal Spot Value: Nominal focal spot value
Inherent Filtration: Min. inherent filtration

Tube Model: Model code
Tube Manufacturer: Manufacturer
X-ray Field: X-ray field size

2D barcode at bottom right: Label code

X-ray Tube Head Assembly Label

Head No.: Serial number
DATE OF MFG.: Date of manufacture
TUBE ANODE No.: Serial number

Long SSD Cone Label (option)

TYPE: Type
X-RAY FIELD: X-ray field size
Ser. No.: Serial number

Electromagnetic Disturbances (EMD)

The Veraview iX (Model V080, hereafter “this device”) conforms to IEC 60601-1-2 Edition 4.1, the relevant international standard for electromagnetic disturbances (EMD).

Use Environment

The use environment of this device is the Professional healthcare facility environment.

WARNING

- Use of this device adjacent to or stacked with other equipment should be avoided because it could result in improper operation. If such use is necessary, this device and the other equipment should be observed to verify that they are operating normally.
- Use of accessories, transducers and cables other than those specified or provided by us could result in increased electromagnetic emissions or decreased electromagnetic immunity of this device and result in improper operation.
- Portable RF communications equipment (including peripherals such as antenna cables and external antennas) should be used no closer than 30 cm (12 inches) to any part of the V080, including cables specified by the manufacturer. Otherwise, degradation of the performance of this device could result.
- RFID readers and electronic article surveillance (EAS) systems should not be near from any part of this device.

Cable List

No.	Name	Cable Length, Shielding	SIP/SOP & In/Out Port Type
1	Signal Output Cable	Max. 20 m, Un-shielded	SIP/SOP
2	Signal Input/Output Cable for Dixelmega	2.5 m, Shielded	SIP/SOP

Compliance for Each EMISSIONS and IMMUNITY Standards

Emissions Test	Compliance	Electromagnetic Environment – Guidance
Conducted disturbance CISPR 11	Group 1 Class B	This device uses RF energy only for its internal function. Therefore, its RF emissions are very low and are not likely to cause any interference in nearby electronic equipment.
Radiated disturbance CISPR 11	Group 1 Class B	This device is suitable for use in all establishments, including domestic establishments and those directly connected to the public low-voltage power supply network that supplies buildings used for domestic purposes.
Harmonic current IEC 61000-3-2	Class A	
Voltage fluctuations and flicker IEC 61000-3-3	Clause 5	

Immunity Test	IEC 60601 Test Level	Compliance Level	Electromagnetic Environment – Guidance
Electrostatic discharge (ESD) IEC 61000-4-2	±8 kV contact ±2 kV, ±4 kV, ±8 kV, ±15 kV air	±2 kV, ±4 kV, ±6 kV, ±8 kV contact ±2 kV, ±4 kV, ±8 kV, ±15 kV air	Floors should be wood, concrete or ceramic tile. If floors are covered with synthetic material, the relative humidity should be at least 30%.
Electrical fast transients/bursts IEC 61000-4-4	±2 kV for power supply lines ±1 kV for input/output lines	±2 kV for power supply lines ±1 kV for input/output lines	Mains power quality should be that of a typical commercial or hospital environment.
Surge IEC 61000-4-5	<u>AC/DC power</u> ±0.5 kV, ±1 kV line(s) to line(s) ±0.5 kV, ±1 kV, ±2 kV line(s) to earth <u>Signal input/output</u> ±2 kV line(s) to earth	<u>AC/DC power</u> ±0.5 kV, ±1 kV line(s) to line(s) ±0.5 kV, ±1 kV, ±2 kV line(s) to earth <u>Signal input/output</u> *1 ±2 kV line(s) to earth	Mains power quality should be that of a typical commercial or hospital environment.
Voltage dips, short interruptions and voltage variations on power supply lines IEC 61000-4-11	<u>dips</u> 0% U_T : 0.5 cycle (at 0, 45, 90, 135, 180, 225, 270, 315°) 0% U_T : 1 cycle (at 0°) 70% U_T : 25/30 cycles (at 0°) 25 (50 Hz)/30 (60 Hz) <u>short interruptions</u> 0% U_T : 250/300 cycles 250 (50 Hz)/300 (60 Hz)	<u>dips</u> 0% U_T : 0.5 cycle (at 0, 45, 90, 135, 180, 225, 270, 315°) 0% U_T : 1 cycle (at 0°) 70% U_T : 25/30 cycles (at 0°) 25 (50 Hz)/30 (60 Hz) <u>short interruptions</u> 0% U_T : 250/300 cycles 250 (50 Hz)/300 (60 Hz)	Mains power quality should be that of a typical commercial or hospital environment. If user of this device requires continued operation during power mains interruptions, it is recommended that this device be powered from an uninterruptible power supply or a battery.
Power frequency (50/60 Hz) magnetic field IEC 61000-4-8	30 A/m (r.m.s.) 50 Hz or 60 Hz	30 A/m (r.m.s.) 50 Hz or 60 Hz	Power frequency magnetic field should be at levels characteristic of a typical location in a typical commercial or hospital environment.
Proximity magnetic fields IEC61000-4-39	<u>30 kHz</u> CW, 8 A/m <u>134.2 kHz</u> 2.1 kHz, 65 A/m <u>13.56 MHz</u> 50 kHz, 7.5 A/m	<u>30 kHz</u> CW, 8 A/m*2 <u>134.2 kHz</u> 2.1 kHz, 65 A/m*3 <u>13.56 MHz</u> 50 kHz, 7.5 A/m*3	The proximity magnetic field should be at a level characteristic of magnetic fields emitted from RFID, IH (Induction Heating), etc.
NOTE 1: U_T is the a.c. mains voltage prior to application of the test level. NOTE 2: r.m.s.: root mean square			

*1: Not applicable because it does not connect directly to outdoor cable.

*2: This test is not applicable since this device is not intended for use in the HOME HEALTHCARE ENVIRONMENT.

*3: This test is not applicable since this device does not use a circuit that is sensitive to magnetic fields, such as a Hall element or a magnetic resistance element.

Immunity Test	IEC 60601 Test Level	Compliance Level	Electromagnetic Environment – Guidance
Conducted RF IEC 61000-4-6	3 V ISM ^(c) frequency band: 6 V 150 kHz to 80 MHz	3 V ISM ^(c) frequency band: 6 V 150 kHz to 80 MHz	Portable and mobile RF communications equipment should be used no closer to any part of this device, including cables, than the recommended separation distance calculated from the equation applicable to the frequency of the transmitter.
Radiated RF IEC 61000-4-3	3 V/m 80 MHz to 2.7 GHz	3 V/m 80 MHz to 2.7 GHz	<p>Recommended separation distances</p> $d = 1.2\sqrt{P}$ $d = 1.2\sqrt{P}$ $d = 2.3\sqrt{P}$ $d = \frac{6}{E} \sqrt{P}$ <p>150 kHz to 80 MHz 80 MHz to 800 MHz 800 MHz to 2.7 GHz Portable wireless RF communication equipment</p> <p>Where P is the maximum output power rating of the transmitter in watts (W) according to the transmitter manufacturer, E is the compliance level in V/m and d is the recommended separation distance in meters (m).</p> <p>Field strengths from field RF transmitters, as determined by an electromagnetic site survey^(a), should be less than the compliance level in each frequency range^(b).</p> <p>Interference may occur in the vicinity of equipment marked with the following symbol:</p> 
	27 V/m 385 MHz	27 V/m 385 MHz	
	28 V/m 450 MHz	28 V/m 450 MHz	
	9 V/m 710, 745, 780 MHz	9 V/m 710, 745, 780 MHz	
	28 V/m 810, 870, 930, MHz	28 V/m 810, 870, 930, MHz	
	28 V/m 1720, 1845, 1970 MHz	28 V/m 1720, 1845, 1970 MHz	
	28 V/m 2450 MHz	28 V/m 2450 MHz	
	9 V/m 5240, 5500, 5785 MHz	9 V/m 5240, 5500, 5785 MHz	

NOTE 1: At 80 MHz and 800 MHz, the higher frequency range applies.

NOTE 2: These guidelines may not apply in all situations. Electromagnetic propagation is affected by absorption and reflection from structures, objects and people.

^(a) Field strengths from fixed transmitters, such as base stations for radio (cellular/cordless) telephones and land mobile radios, amateur radio, AM and FM radio broadcast and TV broadcast cannot be predicted theoretically with accuracy. To assess the electromagnetic environment due to fixed RF transmitters, an electromagnetic site survey should be considered. If the measured field strength in the location in which this device is used exceeds the applicable RF compliance level above, this device should be observed to verify normal operation. If abnormal performance is observed, additional measures may be necessary, such as reorienting or relocating this device.

^(b) Over the frequency range 150 kHz to 80 MHz, field strengths should be less than 3 V/m.

^(c) The ISM (Industrial, Scientific and Medical) bands between 0.15 MHz and 80 MHz are 6.765 MHz to 6.795 MHz; 13.553 MHz to 13.567 MHz; 26.957 MHz to 27.283 MHz; and 40.66 MHz to 40.70 MHz.

Pass/Fail Criteria on Immunity Test

- No X-ray irradiation without an active operation of the emission button or emission key.
- X-ray termination is done by releasing the emission button or emission key.

NOTE:

On fail condition due to electromagnetic disturbance, X-ray termination would not be done by releasing the Emission button or emission key, or X-ray would be irradiated without an active operation of the Emission button or emission key.



Development and Manufacturing

J. MORITA MFG. CORP.

680 Higashihama Minami-cho, Fushimi-ku, Kyoto 612-8533, Japan
T +81. (0)75. 611 2141, F +81. (0)75. 622 4595

Morita Global Website
www.morita.com

Distribution

J. MORITA CORP.

3-33-18 Tarumi-cho, Suita-shi, Osaka 564-8650, Japan
T +81. (0)6. 6380 1521, F +81. (0)6. 6380 0585

J. MORITA USA, INC.

9 Mason, Irvine CA 92618, USA
T +1. 949. 581 9600, F +1. 949. 581 8811

J. MORITA EUROPE GMBH

Justus-von-Liebig-Strasse 27b, 63128 Dietzenbach, Germany
T +49. (0)6074. 836 0, F +49. (0)6074. 836 299

MORITA DENTAL ASIA PTE. LTD.

150 Kampong Ampat #06-01A KA Centre, Singapore 368324
T +65. 6779. 4795, F +65. 6777. 2279

J. MORITA CORP. AUSTRALIA & NEW ZEALAND

Suite 2.05, 247 Coward Street, Mascot NSW 2020, Australia
T +61. (0)2. 9667 3555, F +61. (0)2. 9667 3577

J. MORITA CORP. MIDDLE EAST

4 Tag Al Roasaa, Apartment 902, Saba Pacha 21311 Alexandria, Egypt
T +20. (0)3. 58 222 94, F +20. (0)3. 58 222 96

MORITA DENTAL INDIA PRIVATE LIMITED

Khasra No. 9/12/3 Sector M12, Village, Bhangrola on 2nd Floor Gurugram,
Gurgaon, Haryana 122-505, India
T +91 12 4360 2516

J. MORITA MFG. CORP. INDONESIA

28F, DBS Bank Tower, Jl. Prof. Dr. Satrio Kav. 3-5, Jakarta 12940, Indonesia
T +62-21-2988-8332, F + 62-21-2988-8201

SIAMDENT CO., LTD.

71/10 Moo 5 T. Tharkham A. Bangpakong Chachuengsao 24130 Thailand
T +66 (0) 3857 3042, F +66 (0) 3857 3043
www.siamdent.com

EU Authorized Representative under the European Directive 93/42/EEC



Medical Technology Promedt Consulting GmbH

Ernst-Heckel-Straße 7, 66386 St. Ingbert, Germany T +49. 6894 581020, F +49. 6894 581021

The authority granted to the authorized representative, Medical Technology Promedt Consulting GmbH, by J. MORITA MFG. CORP. is solely limited to the work of the authorized representative with the requirements of the European Directive 93/42/EEC for product registration and incident report.

Diagnostic and Imaging Equipment

Treatment Units

Handpieces and Instruments

Endodontic Systems

Laser Equipment

Laboratory Devices

Educational and Training Systems

Auxiliaries