



Er:YAG Laser for Dentistry
AdvErL EVO

INSTRUCTIONS FOR USE



Thank you for purchasing the AdvErL EVO.

For optimum safety and performance, read this manual thoroughly before using this device and pay close attention to the warnings, cautions and notes.

Keep this manual in a handy place for ready reference.

Trademarks and Registered Trademarks:

Parts of the names of companies, products, services, etc. used in this manual may contain either trademarks or registered trademarks owned by each company.

© 2012 J. MORITA MFG. CORP.

Table of Contents





	Page
PREVENT ACCIDENTS.....	4
DISCLAIMER	5
1. DEVICE DESCRIPTION	6
2. PARTS IDENTIFICATION AND ACCESSORIES.....	9
(1) Parts Identification.....	9
(2) Accessories.....	11
(3) Labels	13
(4) Symbols.....	14
3. OPERATION	15
(1) Set Up.....	15
(2) Starting Device.....	17
(3) Attaching Contact Tip to Handpiece	19
(4) Operation Procedure.....	21
1) Set Laser Irradiation Conditions	21
2) Laser Emission Procedure.....	24
3) Emergency Stop.....	25
4) Memory	27
(5) Stopping Device	32
(6) Moving Device.....	33
(7) Making Other Setting and Checking Information	34
4. STERILIZATION, REPLACEMENT PARTS, AND STORAGE.....	41
(1) Handpiece Grip, Hanger, Contact Tips and Tip stand Cleaning and Sterilization.....	42
1) Cleaning (Always perform this procedure prior to sterilization).....	42
2) Autoclaving (sterilization) (Always perform this procedure after cleaning and before use)	43
(2) Cleaning the Main Unit	44
(3) Maintenance	45
1) Grease Handpiece	45
2) Lens Cleaning.....	46
3) Spray Water Bottle (Sterile Water for Spray) Replacement	47
(4) Storage.....	48
(5) Replacement Parts	49
5. INSTALLATION	50
< Cautionary Remarks on Installation >	50
1) Water Tube.....	50
2) Foot Switch	51
3) Remote Interlock Connector.....	51

	Page
6. ANNUAL MAINTENANCE, INSPECTION AND CALIBRATION.....	52
Annual Maintenance	52
1) Outline	52
2) Function Check (Interlock).....	52
3) Replacement	52
4) Other Parts	52
5) Calibration of Laser Output.....	52
7. CLINICAL APPLICATIONS.....	53
(1) Introduction.....	53
(2) Er:YAG Laser Ablation	53
2.1) Tissue Interaction.....	53
2.2) Parameter of Laser Ablation.....	53
(3) Warnings and Notes.....	54
(4) Adverse Effects	54
(5) AdvErL EVO INTENDED FOR USE	54
(6) Clinical Procedure	56
6.1) General	56
6.2) Tissue Effects of Er:YAG Laser.....	56
6.3) Pulse Energy (Energy Level Setting: mJ).....	56
6.4) PPS (Hz)	56
6.5) Laser Energy Density.....	56
6.6) Type of Contact Tips	58
6.7) Contact Tips and Treatment Settings	60
(7) Bibliography.....	63
8. TROUBLESHOOTING	65
Explanation of Error and Caution Messages.....	65
Troubleshooting for Problems Other than Error Messages.....	68
9. TECHNICAL DESCRIPTION	71
10. ELECTROMAGNETIC COMPATIBILITY (EMC).....	73

PREVENT ACCIDENTS

Most operation and maintenance problems result from insufficient attention being paid to basic safety precautions and not being able to foresee the possibilities of accidents. Problems and accidents are best avoided by foreseeing the possibility of danger and operating this device in accordance with the manufacturer's recommendations. First thoroughly read all precautions and instructions pertaining to safety and accident prevention; then, operate this device with the utmost caution to prevent either damaging this device itself or causing bodily injury.

The following symbols and expressions indicate the degree of danger and harm that could result from ignoring the instructions they accompany:

- | | |
|---|---|
|  DANGER | This warns the user of the extremely serious injury or complete destruction of the equipment as well as other property damage including the possibility of fire. |
|  WARNING | This warns the user of the possibility of extremely serious injury or complete destruction of the equipment as well as other property damage including the possibility of fire. |
|  CONTRAINDICATION | This identifies methods which must not be used or purposes which the equipment is not suited for. |
|  CAUTION | This warns the user of the possibility of mild injury or damage to the equipment. |
| NOTE | This alerts the user of important points concerning operation or the risk of equipment damage. |

The user (e.g., healthcare facility, clinic, hospital etc.) is responsible for the management, maintenance, and use of medical devices.

This device must not be used for any purpose other than incision, hemostasis, coagulation and vaporization of biological tissues.

Federal law restricts this device to sale by or on the order of a dentist (valid only for U.S.A.). Only licensed professionals who have successfully completed training should use the laser and accessories.

Disclaimer

- J. MORITA MFG. CORP. will not be responsible for accidents, instrument damage, or bodily injury resulting from:
 - (1) Repairs made by personnel not authorized by J. MORITA MFG. CORP.
 - (2) Any changes, modifications, or alterations of its products.
 - (3) The use of products or instrument made by other manufacturers, except for those procured by J. MORITA MFG. CORP.
 - (4) Maintenance or repairs using parts or components other than those specified by J. MORITA MFG. CORP. and other than in their original condition.
 - (5) Operating the instrument in ways other than the operating procedures described in this manual or resulting from the safety precautions and warnings in this manual not being observed.
 - (6) Workplace conditions and environment or installation conditions which do not conform to those stated in this manual such as improper electrical power supply.
 - (7) Fires, earthquakes, floods, lightning, natural disasters, or acts of God.
- The useful life of the AdvErL EVO is 8 years from the date of installation provided it is regularly and properly inspected and maintained.
- J. MORITA MFG. CORP. will supply replacement parts and be able to repair the product for a period of 10 years after the manufacture of the product has been discontinued.

WARNING

- *Never use this device for patients who have a pacemaker or an implantable cardioverter defibrillator (ICD); it could cause these devices to operate erratically.*

CAUTION

- *Electromagnetic waves from mobile terminals, smart devices, transceivers, and remote control devices could cause this device to operate erratically. Turn off all communication devices of this type in the operating area.*
- *As far as possible do not use this device near or at the same time as other devices. If this cannot be avoided, make sure both units operate properly before using them for treatment.*

1. Device Description

1. Operational Principles

The AdvErL EVO consists of a combination of four systems and the Hollow Waveguide.

(1) Main Unit

1) Laser Oscillator System

The Er:YAG laser (2.94 μm) is generated by exciting the Er:YAG rod by a light of flash lamp in the resonator, and is emitted from the half reflection mirror. The laser beam is partially reflected by a beam splitter, and goes into the laser sensor for power monitoring, and laser power is controlled.

The safety shutter (beam shutter) opens after the Ready key is in the on state and the foot switch is depressed while no error condition, and the laser beam is lead to the laser aperture.

After the shutter, the laser beam is mixed with an aiming beam (650 nm) and goes on to the Hollow Waveguide via laser aperture.

2) Electrical System

The electrical system consists of the laser power supply, control unit, LCD touch screen control panel, key switch, and foot switch. The laser power supply is consists of a high voltage circuit, trigger circuit, and other components, and is used to light the flash lamp.

3) Software

The software for the AdvErL EVO controls all its operations, maintains its safety, and makes sure that the output is accurate and exact.

The Laser output conditions including output power, number of repetitions etc. is set with the various buttons on the touch panel display. Once the device is in its Ready condition, the laser beam is emitted by depressing the foot switch.

In this process, parameter for safety is checked, and if anything abnormal is detected, an error is displayed and laser irradiation is stopped.

4) Cooling System

The AdvErL EVO is a water-cooled device.

Water is stored in a tank inside the Main unit, and circulates between the resonator and heat exchanger.

The heated water is cooled by the water-and-air heat exchanger and returns to the water tank.

(2) Hollow Waveguide

The hollow waveguide transmits the laser beam to the contact tip attached to the end of the handpiece. There are also water and air lines that provide spray to cool the treatment tissue. When the foot switch is depressed, the laser beam, water and air are all emitted from the end of the contact tip.

Contact tips, handpiece grip, and the hollow waveguide are applied parts.

2. Biological Effects

An Er:YAG laser emits an infrared beam with a wavelength of 2.94 μm which is readily absorbed by water contained by both hard and soft tissues. As a result, the energy of the laser beam instantly vaporizes the water molecules in hard tooth tissue causing the tissue to crumble away.

These beams can also resect soft tissue.

3. Safety Procedures for Use of Laser Surgical Device

Post or display a “danger notice plate” or “warning notice plate” in an easily visible place outside the laser surgery area.

(1) Safety Measures to Protect Eyes, Skin, etc

1) A serious injury will result if the laser beam directly strikes the eyes or skin. It is particularly essential to avoid damage to eyes (such as injuring the cornea etc).

The user, patient and all other people inside the laser surgery area must always wear Laser Safety Glasses to protect their eyes from the laser beam.

In all testing, instruction or training situations, the laser surgeon, instructors and students also must wear Laser Safety Glasses.

- 2) When entering the operation area of this device, always put on the Laser Safety Glasses. Furthermore, never look the laser beam directly even if Laser Safety Glasses are worn.
- 3) Regularly inspect the Laser Safety Glasses to make sure there are no holes or fine cracks and make sure that they are physically sound.
- 4) Before using this device, the user must undergo a dermatology and ophthalmology examinations. Moreover, the user must undergo regular dermatology and ophthalmology examinations.
- 5) Due to the harmful effects laser beam emission can have on eyes and skin, it is necessary to undergo an ophthalmology and dermatology examinations. There are two reasons for this.
 1. To ascertain the state of the skin and eyes before performing laser beam emission.
 2. To detect damage to eyes or skin at an early stage.
- 6) If the user has suspected damage to eyes or skin, they must be examined by a doctor as soon as possible.

(2) Safety Measures to Protect Patient

The doctor must explain to the patient all crucial points regarding treatment involving the laser surgery device.

When using the laser surgery device, no matter what the circumstances, the doctor must always have the patient wear Laser Safety Glasses to protect the patient's eyes. The patient must follow the directions of the doctor. Do not touch any terminals of this device and the patient at the same time.

(3) Safety Measures to Protect People other than User and Patient (Observers, etc)

- 1) The user must prohibit people other than the user and patient from being in the area where the laser surgery device is used. If it is necessary to allow a person to enter the laser surgery area, it should be limited to cases where the person is undertaking instruction and training.
When the user is using the laser surgery device, a notice stating laser surgery is in progress should be placed where all people visiting the area will notice it such as outside the entrance of the laser surgery room.
- 2) Only people recognized as authorized users may operate this device.
- 3) The user of this device must have complete proficiency in the operational procedures of this device.
- 4) The user must have received comprehensive instruction and training on the hazards of laser beams.
- 5) Any dentists, doctors, nurses or dental hygienists who might have to enter the laser surgery area must receive a comprehensive explanation on the hazards of laser beams.
- 6) The user of this device must never direct the laser beam to reflective surfaces or people other than the patient being treated.
- 7) The key of this device must be taken care of and kept by a supervisor and when this device is not in use, the key must always be removed from this device.
- 8) Wear only Laser Safety Glasses that have been regularly inspected.

(4) Prevention of Laser Beam Reflection by Surgical Instruments, Equipment, etc.

As far as possible, remove all reflective instruments from the laser surgery area.

Take reflection protection measures by covering items that could reflect a laser beam such as surgical instruments and equipment with wet gauze or some other suitable material.

Pay attention to the reflection of the laser by metal objects, and use anti-reflection treated surgical instruments.

This laser beam is dangerous to eyes, skin, mucous membranes etc. even when reflect from a diffusing surface.

Ensure the measures to eliminate the hazard of reflected light outlined below are comprehensively followed.

- 1) Make sure the surgical instruments and equipment such as forceps and suction tubes have undergone processing to prevent reflection and take all possible measures to reduce reflection of laser beam.
- 2) Never irradiate laser on a reflective surface.
- 3) Take care to prevent reflection by dental prosthetics etc.
- 4) No one should stand behind the patient or laser surgeon.
- 5) When using a surgical instruments that has not undergone processing to prevent reflection, cover it with gauze soaked with physiological saline.

(5) Measures to Prevent Fire

The heat generated by the laser beam could cause significant fire damage. Make sure the laser beam will not strike any combustible substances within the laser surgery area.

(6) Accidental Irradiation Precautions

- 1) Before irradiating a laser, biotissue that could be exposed to laser irradiation should be well-covered with gauze that has been soaked in a saline solution so that it cannot be harmed by accidental laser irradiation.
- 2) Always carefully consider the output power and irradiation time required for treatment and avoid excessive laser irradiation.
- 3) Both patient and laser surgeon must wear Laser Safety Glasses. If the laser beam (direct beam or diffused beams) strikes the eyes, it could cause blindness. Even when wearing Laser Safety Glasses, never allow the beam to strike the eyes directly.

2. Parts Identification and Accessories

(1) Parts Identification

Main Unit

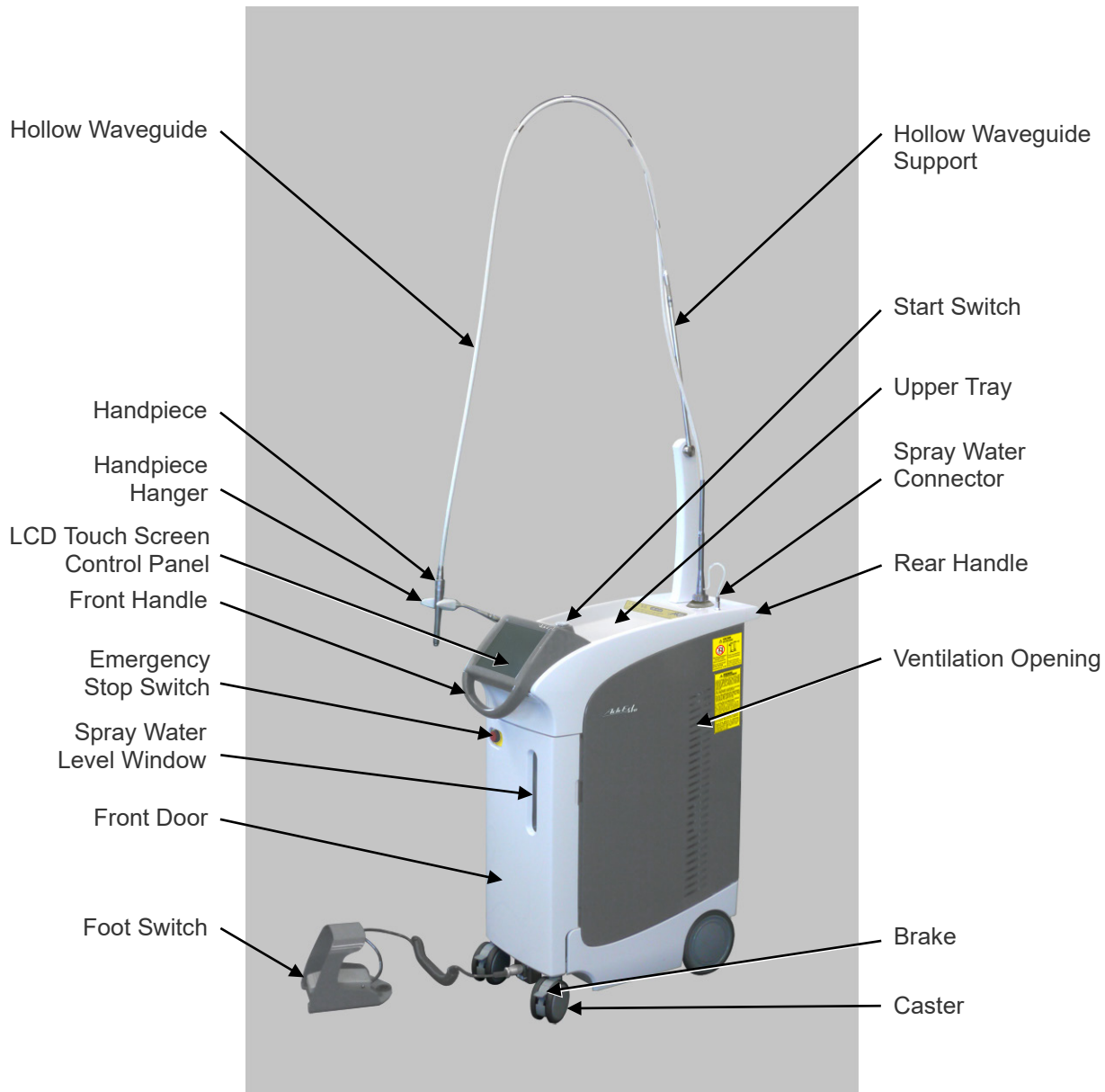

Back

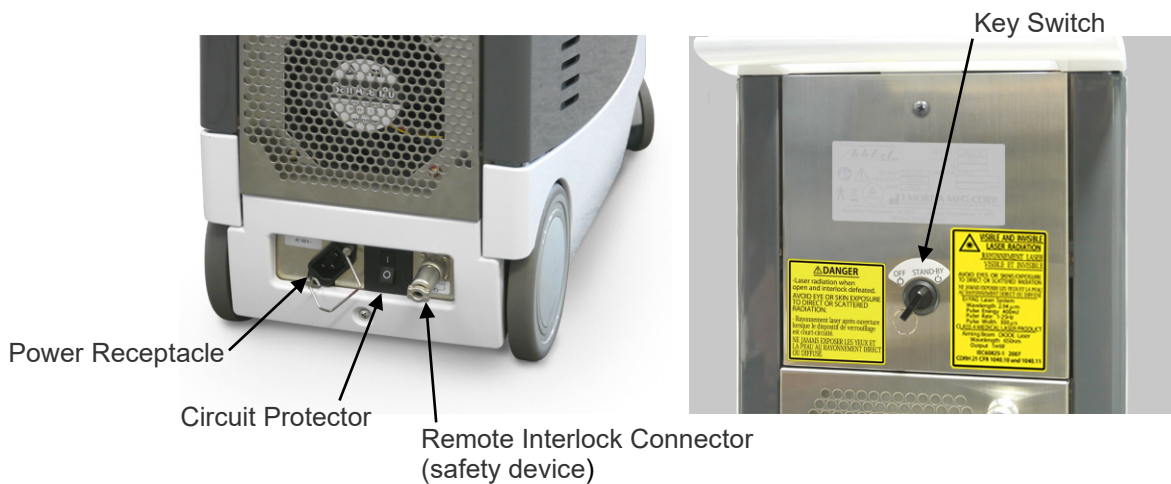



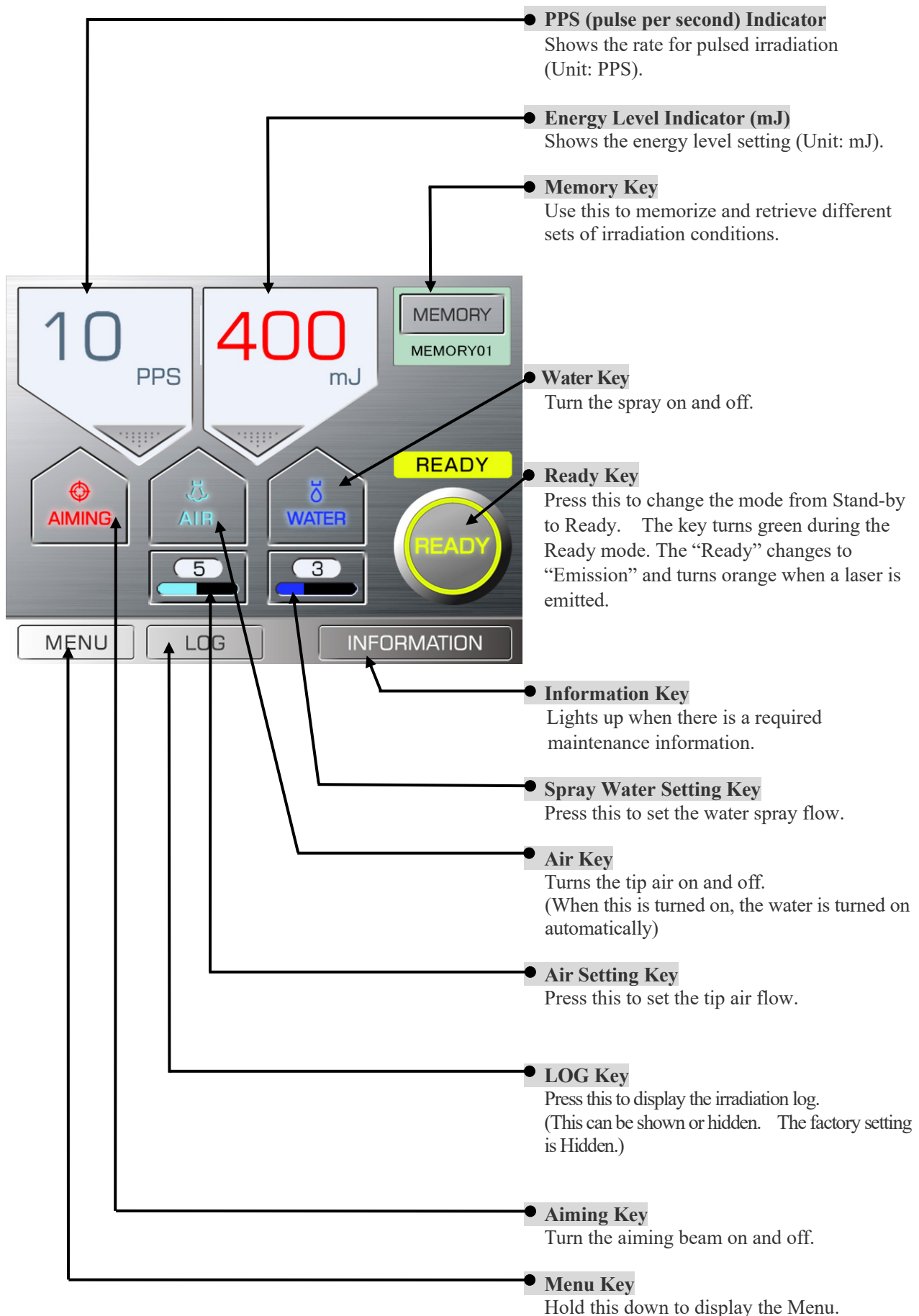







LCD Touch Screen Control Panel (Main Panel)





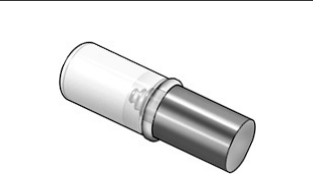

(2) Accessories



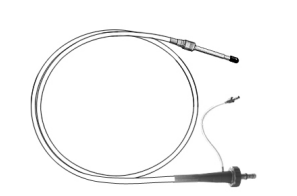

Contact Tips

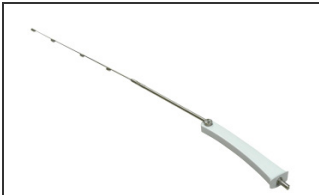
			
C400F (1)	C600F (1)	C800F (1)	
			
S600T (1)	PS400TS (2)	PS600TS (1)	PS600T (1)

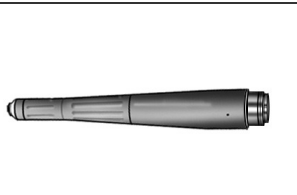
			
Keys (2)	Grease Applicator (1)	Laser Safety Glasses (3 pairs)	Lens Cleaner (1)

			
Tip Stand (1)	Foot Switch (1)	Remote Interlock Connector (1)	Hollow Waveguide (1)

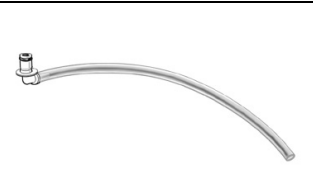
			
Hollow Waveguide Support (1)	Power Cord (1)	Handpiece Hanger (2)	Handpiece Grips (2)

			
Deionized Water Tank for Cooling, 2.5-liters	Deionization Filter Cartridge (1)	Drain Tube (1)	Wheel locking device (1)

WARNING
★ To Patients ★

This is a designated laser surgery area.
Follow the following rules:

1. Follow the instructions of doctors and nurses.
2. Do not touch or handle any of the instruments and equipment in this area.

Surgical Laser Supervisor

Patient warning plate

 **WARNING**
To Operators of Laser Surgical Equipment

1. This laser surgical equipment may be operated only by those individuals whose name appears in the list of registered users.
2. Before use, record the date and time of use, the purpose and the surgeon's name in the Surgical Laser Log, and then request the key for the instrument from the supervisor of surgical laser equipment.
3. Before use, post a warning notice such as "Laser In Use" outside the surgical laser room.
4. If the laser equipment does not operate properly, stop using it immediately and report to the supervisor.
5. After use, inspect the equipment and perform all necessary maintenance procedures.
6. After use, immediately return the key to the supervisor, and record the length of time the equipment was used and other pertinent facts in the Surgical Laser Log.

Operator warning plate

WARNING

 **Laser In Use**
Eye Protection Required

Eye warning plate

 **DANGER**

LASER RADIATION
AVOID EYE OR SKIN EXPOSURE
TO DIRECT OR SCATTERED
RADIATION

Er:YAG LASER System
Wavelength 2.94 μm Pulse Energy 400mJ
Pulse Rate 1-25Hz Pulse Width 300 μs

CLASS 4 LASER

Laser Danger plate

 **DANGER**

Laser Light and Equipment Dangers
The laser emitted by this equipment could cause serious injury to eyes and skin; put on safety glasses or take other suitable safety measures before use.
Do not apply excessive force to the tip; it could break and cut the patient or fragments could be left in the surgical area. Handle the tips carefully.
Keep output power within the specified limit for the tip.
When not in use, do not leave the equipment in a place where it might freeze.

Tip Air Dangers
Tip air for spray is emitted when the spray and air switches are turned on.
Take care when performing operations inside body cavities and lumens; tip air could cause emphysemas or a gas embolism.
Take care that tip air does not injure tissues.
Also take care that critical tissues such as nerves and blood vessels are not injured by the heat produced by the laser.

Combustion and Explosion Dangers
Never direct the laser beam at combustible objects such as tracheal tubes, fabrics, surgical gowns etc; this could cause these objects to catch on fire.
Never use this laser in the presence of flammable anesthetics or in environments with a high oxygen concentration; this could result in a fire or explosion.
Do not use standard, combustible tracheal tubes made of plastic or rubber.
Avoid contamination and infection; take care that fumes and particulates produced by laser irradiation are not inhaled and do not get in anyone's eyes.

Operation Danger plate

Optional Tips and Parts



R200T



R300T



R600T



P400T



P400FL



PS400T



PSM600T



CS600F



* Only for R200T and R300T

R Handpiece Grip



Touch Panel
Protective Sheet

(3) Labels

Read All Warning and Caution Labels

WARNING
AVERTISSEMENT

SUBCUTANEOUS EMPHYSEMA
EMPHYSEME SOUS-CUTANE

Use with care. Cooling air from the contact tip can cause subcutaneous emphysema or air embolism.
À utiliser avec prudence. L'air de refroidissement sortant de la pointe de contact peut provoquer un emphyseme sous-cutané ou une embolie gazeuse.



AVOID EXPOSURE

DANGER

LASER RADIATION—AVOID EYE OR SKIN EXPOSURE TO DIRECT OR SCATTERED RADIATION.

Er:YAG LASER System
Wavelength 2.94 μm Pulse Energy 400mJ
Pulse Rate 1-25Hz Pulse Width 300 μs
CLASS IV LASER PRODUCT

CAUTION
ATTENTION

Before use, do not fail to connect the water tube for spray delivery
Avant toute utilisation, ne pas oublier de raccorder le tube d'eau pour la pulvérisation.

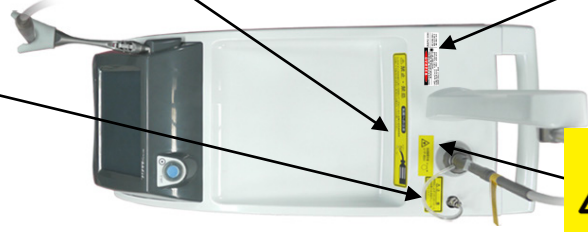

LASER APERTURE AT FIBER END

CAUTION
ATTENTION

Do not apply excessive force or stress to the transmission cable. Never bend it into a curve with a radius of less than 6 cm.
Ne pas appliquer de force ou de contraintes excessives sur le câble de transmission. Ne jamais le courber à un rayon inférieur à 6 cm.

CAUTION
ATTENTION

(inside of the device)

STOP

LASER STOP

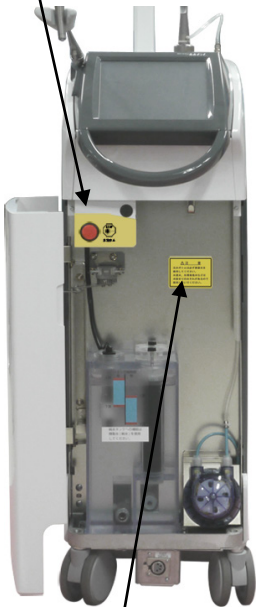

CAUTION
ATTENTION

Be sure to use distilled water. Using tap water or a saline solution could plug up the water lines.
Veiller à utiliser de l'eau distillée. L'utilisation d'eau du robinet ou d'une solution saline pourrait boucher les canalisations d'eau.



CAUTION
ATTENTION

Risk of overbalance, DO NOT PUSH side of equipment.
Risque de basculement : NE PAS POUSSER l'équipement par le côté.

Push rear end first to go over bumps.
Pousser d'abord par l'arrière pour passer les zones irrégulières du sol.

WARNING
AVERTISSEMENT

Electromagnetic waves from cell phones, transceivers, and remote control devices could cause this instrument to operate erratically and cause serious injury to the skin and eyes.
All individuals in the laser use area must wear laser safety glasses. Do not take cell phones, transceivers, remote control devices of other radio frequency (RF) equipment into the area where the laser is in use.
Les ondes électromagnétiques émises par les téléphones cellulaires, les émetteurs-récepteurs et les télécommandes pourraient nuire au bon fonctionnement de cet instrument et causer des lésions graves de la peau et des yeux.
Toute personne se trouvant dans la zone d'utilisation du laser doit porter des lunettes de protection adaptées. Ne pas faire pénétrer de téléphones cellulaires, d'émetteurs-récepteurs et de télécommandes d'autres équipements radiofréquence (RF) dans la zone d'utilisation du laser.

DANGER

-Laser radiation when open and interlock defeated. AVOID EYE OR SKIN EXPOSURE TO DIRECT OR SCATTERED RADIATION.
- Rayonnement laser après ouverture lorsque le dispositif de verrouillage est court-circuité.
NE JAMAIS EXPOSER LES YEUX ET LA PEAU AU RAYONNEMENT DIRECT OU DIFFUSE.

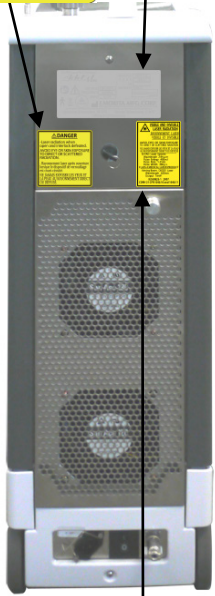

VISIBLE AND INVISIBLE LASER RADIATION
RAYONNEMENT LASER VISIBLE ET INVISIBLE





























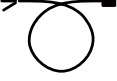





AVOID EYES OR SKINS EXPOSURE TO DIRECT OR SCATTERED RADIATION
NE JAMAIS EXPOSER LES YEUX ET LA PEAU AU RAYONNEMENT DIRECT OU DIFFUSE.

Er:YAG Laser System
Wavelength 2.94 μm Pulse Energy 400mJ
Pulse Rate 1-25Hz Pulse Width 300 μs
CLASS 4 MEDICAL LASER PRODUCT
Aiming Beam: DIODE Laser
Wavelength 650nm
Output 1mW
IEC60825-1 2007
CDRH 21 CFR 1040.10 and 1040.11

Rating Label

(4) Symbols

* Some symbols may not be used.

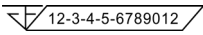
	Serial number		Unique device identifier
	Medical device		Manufacturer
	Date of manufacture		Refer to instructions for use
	Importer		Distributor
	Attention, consult accompanying documents		Type B applied part
	Marking of electrical equipment in accordance with the European Directive 2012/19/EU (WEEE)		cTUVus certification mark (Valid only for U.S.A. and Canada)
	DANGER		No pushing
	Caution		Caution: Laser
	Caution: High Voltage		Emergency laser stop
	Optical fiber applicator		Alternating current
	“ON” / “OFF” (push push)		“ON” for part of equipment
	“OFF” for part of equipment		Remote interlock connector, as defined in 3.74 of IEC60825-1
	GS1 DataMatrix		This way up
	Fragile		Keep away from rain
	Temperature limitation		Humidity limitation
	Atmospheric pressure limitation		Authorized representative in the European Community
	Authorized representative in Switzerland		Country or region (Country Names: Conforming to the ISO 3166-1 alpha-3 codes and EU for European Union) Description noted next to the code is an indication that conforms to the regulations valid only for the relevant country or region.
	Registration number of medical device in Thailand (The 12 -digit sample number shown is for demonstration purposes only.)		

3. Operation

(1) Set Up

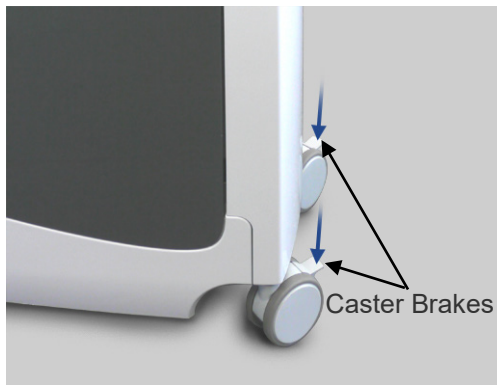

- (1) Put the main unit in position and lock the casters with caster brakes.



- (2) Take the foot switch off its hook and place it on the floor.

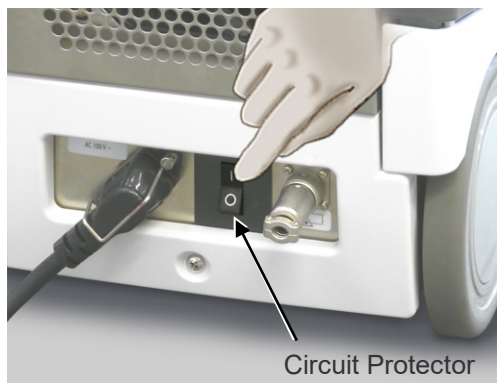

- (3) Turn on the circuit protector on the back of Main unit.



- (4) Pull the handpiece hanger forward.

 **WARNING**

- *When this device is not in use, always remove the key and return it to a supervisor.*
- *Never use, modify, or calibrate this device in any way other than as described in this Instructions for Use. Accidental laser irradiation may occur.*
- *Use of controls or adjustments or performance of procedures other than those specified herein may result in hazardous laser irradiation.*

 **CAUTION**

- *Do not apply excessive force or stress to the hollow waveguide. Never bend it into a curve with a radius of less than 6 cm.*
- *Do not let anyone go between the patient and this device. Do not let personnel not involved with the treatment stand near this device.*
- *If an error occurs, stop using this device immediately and turn it off.*
- *If an error is indicated on the LCD touch screen, stop operating this device immediately.*
- *Do not put this device on a surface that is not level; it could tip over. Make sure the brakes on the casters are on.*
- *Never tilt this device more than 10° when moving it; it could tip over.*
- *Make sure there is enough water in the spray bottle.*
- *To avoid stepping on the foot switch accidentally, decide where it should be and always place it in exactly the same place.*

(2) Starting Device

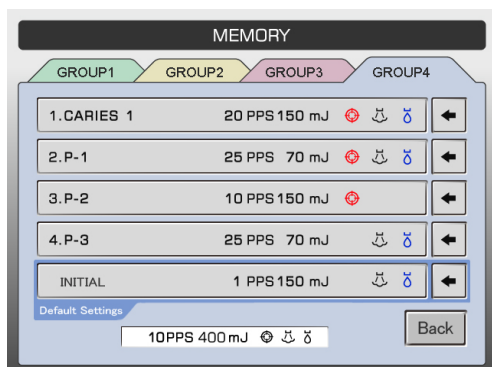
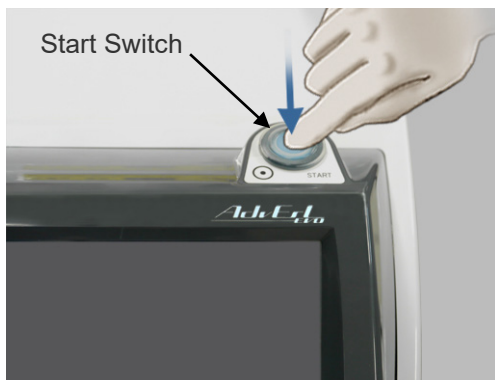
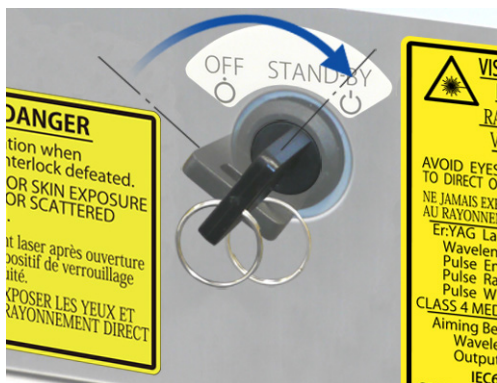

- (1) Put on laser safety glasses.
- (2) Insert the key and turn it to the Stand-by position.
- (3) Press the Start Switch.
 - The warm-up procedure will run for 20 seconds.
 - * The warm-up countdown number will appear on the LCD touch screen.
 - After the warm-up is completed, the LCD touch screen will show the Warning message.
 - * **If the water temperature is less than +15°C (+59°F), the “D” interlock message will appear. In this case, wait for the water to warm up.**
 - * **If the cooling water gets too warm, the fan will speed up and make a louder noise.**
- (4) Make sure that wearing laser safety glasses and press the “Confirm” key.
- (5) The LCD touch screen will show the Main panel and the device will be in the Stand-by mode. The values of the Initial Setting of memory will be reflected when starting up the device.

Initial Setting

The fifth set in the Group 4 (blue tab) is the Initial Setting. These are the values set when the device is first turned on.

The setting can be changed as well as the others. Even the set name “Initial” can be changed to the user’s desired name.

(See page 27)

 **WARNING**

- *A direct, reflected or scattered laser beam can cause permanent blindness. All individuals in the laser use area must wear laser safety glasses supplied with this device. The Laser safety glasses has an OD of 3.5 (or greater) at 2.94 μ m. Other parts of the body should also be protected. The laser beam can cause serious injury to the skin and eyes.*
- *Even if you are wearing laser safety glasses, never look directly into the aperture where the laser comes out; you there is a risk of blindness. Both the main laser and the guide light are dangerous. The laser safety glasses provides only temporary protection.*

 **CAUTION**

- *Use only laser safety glasses specifically designed for the Er:YAG laser. Do not use laser safety glasses meant for use with other types of lasers, the CO₂ laser, for example.*

(3) Attaching Contact Tip to Handpiece

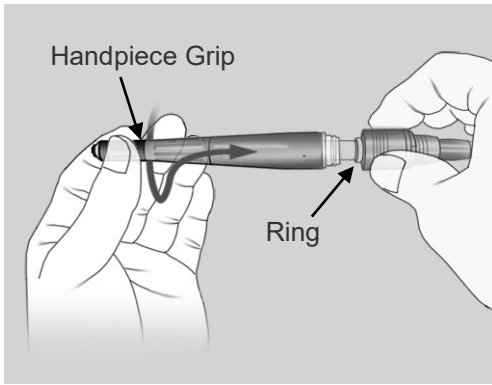

- (1) Hold the ring in one hand and then put the handpiece Grip on by turning it until it clicks into place.

* To remove it, hold the ring and pull it off.

NOTE

- ◆ *When inserting the Handpiece Grip, hold the end of the Handpiece Grip and insert it with turning, or the internal O-ring may be damaged.*
- ◆ *Grease the end of the handpiece periodically to prevent damage to the O-ring. (See page 45.)*

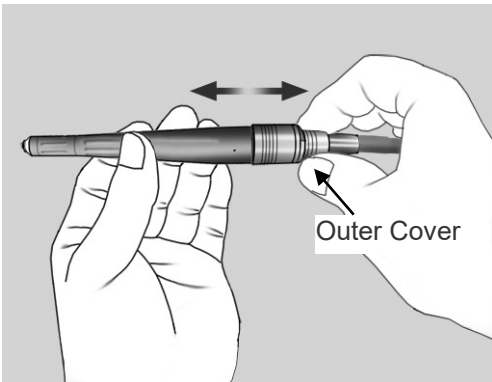

- (2) Hold onto the outer cover of the hollow waveguide and give the Handpiece Grip a light tug to make sure it will not come off.

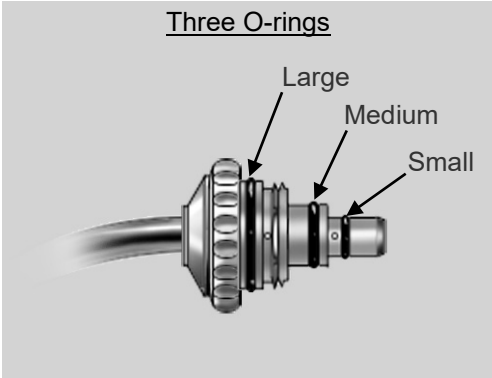

- (3) Make sure the contact tip is clean and free of blood and other contaminants. Make sure all three O-rings are in place.

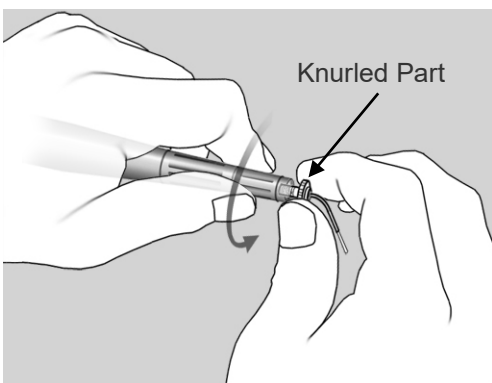

- (4) Grip the knurled part of the contact tip and screw the Handpiece Grip.

CAUTION

- *Always hold the knurled part of the contact tip to screw it on or off; never grip the metal pipe of the contact tip, which could damage the contact tip.*

NOTE

- ◆ *R Handpiece Grip is required for R200T and R300T.*

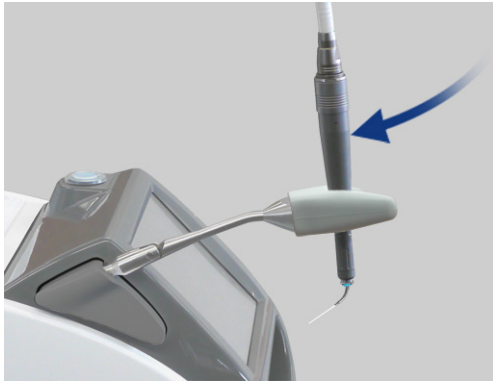

(5) Put the handpiece in its hanger.

NOTE

- ◆ *Be careful not to damage a contact tip when you put the handpiece in its hanger.*
- ◆ *To avoid damaging the contact tip, place the handpiece so that the contact tip faces the Main unit.*

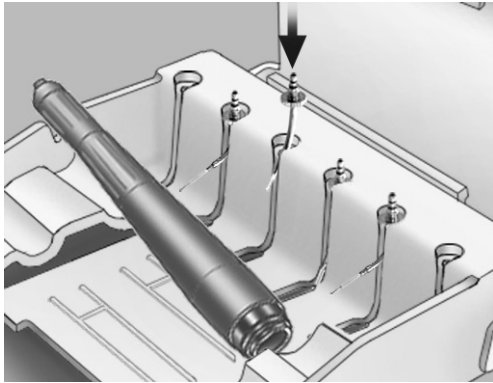

* Put the contact tips in the Tip Stand after taking them out of their cases.

NOTE

- ◆ *The contact tip could be damaged if it is placed upward when closing the top cover of the stand.*

⚠ WARNING

- *Screw the contact tip into the handpiece grip all the way on otherwise the contact tip may come off during use, causing incorrect laser irradiation or swallowing the contact tip.*

⚠ CAUTION

- *Contact tips are consumable and must be replaced periodically. Inspect contact tips carefully before using them (see below). Worn contact tips could overheat and injure the patient.*
 - *Do not use chipped or worn contact tips.*
 - *Do not use contact tips if the laser output seems lower than usual.*
 - *If the guide light is dim or does not appear at all, the contact tip may be damaged.*
- *End of contact tips are sharp and can cause injury; handle them with care.*
- *Use only contact tips specified for AdvErL EVO.*
- *When putting contact tips on and taking them off, turn the key off or put this device in Stand-by mode.*
- *Never emit a laser without having the handpiece and a contact tip installed.*
- *Check the end of contact tips and make sure they are free of blood and other contamination or debris. Otherwise, they could overheat, especially if the tip air and spray water are turned off. Overheated contact tips could injure the patient.*

(4) Operation Procedure

1) Set Laser Irradiation Conditions

For the recommendations for energy levels and PPS (pulses per second), Please refer to 6.7) Contact Tips and Treatment Settings (page 60).

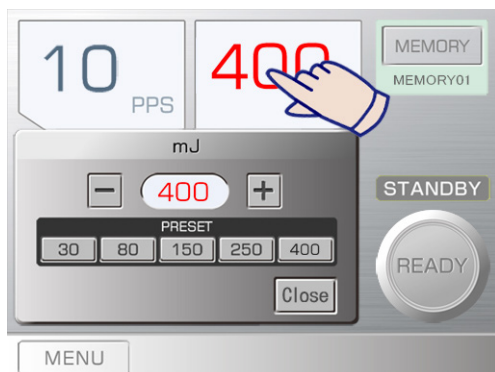

(1) Energy Level

- Press the “mJ” part of the panel; a window to make this setting will appear.
- Press a preset number to change the energy level.
- You can also press the plus or minus key to adjust the energy level.

For less than 100 mJ, values can be set in 5 mJ steps.
For more than 100 mJ, values can be set in 10 mJ steps.
Setting Ranges: 10 pps — 30 mJ to 400 mJ
20 pps — 30 mJ to 170 mJ
25 pps — 30 mJ to 80 mJ

Press “Close” after making the setting.

- Press one of the numbers to make this setting.
- The mJ display turns red if mJ is set at 150 or higher.

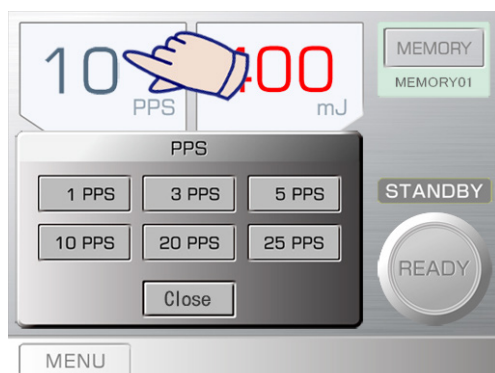

(2) PPS (pulses per second) Setting

- Press the “PPS” part of the panel; a window to make this setting will appear.
- Press one of the numbers to make this setting.
(3 PPS is actually 3.3 pulses per second.)

PPS means pulses (laser shots) per second.

The total amount of energy delivered in one second can be found by multiplying the energy level by the PPS.



(3) Turning Aiming Beam On and Off

A red aiming beam is emitted from the handpiece.

- The aiming beam is emitted when the device is in Ready mode and during laser emission.
- Press the Aiming key to turn the aiming beam on or off.
- Initial setting is on.
* The Aiming Key lights up.
- Press the Aiming Key to turn off the aiming beam if it is not needed; the key light will go out.



(4) Turning Spray Water On and Off

Spray Water is emitted from the end of the contact tip to cool the area being irradiated.

- Press the Water Key to turn the spray water on and off.
- Initial setting is on.
 - * The Water Key lights up.
- Press the Water Key to turn the spray water off if it is not needed; the key light will go out.
 - * The Air Key will turn off automatically when the Water Key is turned off.

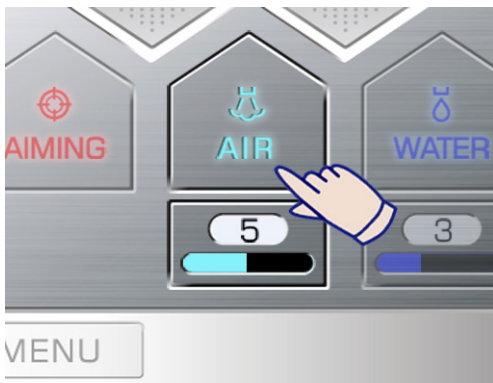

(5) Turning Tip Air On and Off

A mixture of air and water produces a mist water and is emitted from the end of the contact tip.

- Press the Air Key to turn the tip air on and off.
- Initial setting is on.
 - * The Air Key lights up.
- Press the Air Key to turn the Tip Air off if it is not needed; the key light will go out.
 - * The Water Key will turn on automatically when the Air Key is turned on.

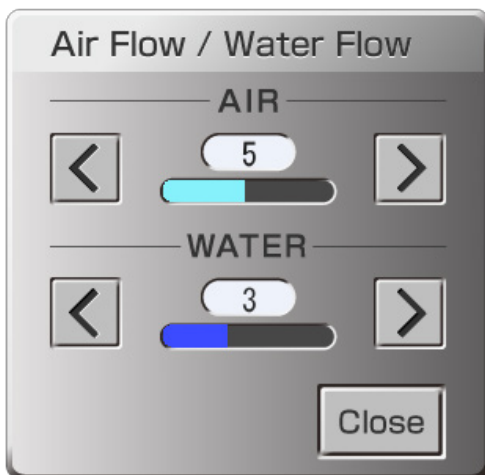

(6) Spray Water and Tip Air Adjustment

- Press the setting key under either the Water or Air Key; a window to make these settings will appear.
- Press the increase (>) or decrease (<) Key to adjust the flow of the water or air.
- Press the “Close” Key when you finish.
- The air and water flows can be adjusted even when the laser beam is being emitted.

 **WARNING**

- *Take great care when using the tip air inside a body cavity or tubular lumen. Raising the air pressure inside a cavity or lumen could force air into a blood vessel through an open wound and result in an air embolism. Also take great care when using the tip air in areas of the oral cavity where it could increase the pressure; this could result in a severe air embolism or subcutaneous emphysema.*
- *Never look the guide light directly; this could result in blindness.*

 **CAUTION**

- *Irradiating hard tooth tissue without using spray water could cause carbonization. When irradiating hard tissue, make sure the spray water is turned on and that enough water is being delivered to the treatment area.*
- *Do not set output powers greater than that specified for the contact tip; this could overheat the contact tip.*
- *Before irradiating the laser, check if the spray water is on or off and what the volume is. Depress the foot switch to the first level to check the spray water.*
- *Make sure the tip air flow is not so strong that it damages tissue.*

2) Laser Emission Procedure



- (1) Press the Ready Key.



- When the preparation for laser emission is completed, the device will be in the Ready mode and the Ready Key will turn green.
 - If the Aiming key is in the on state, the aiming beam will be emitted.
- (2) Before using the laser, make sure the aiming beam is clear and bright. (See page 46)



- (3) Depress the foot switch to its first level to check that spray is properly emitted from the end of contact tip.



- (4) Depress the foot switch all the way down to emit the laser. The Ready Key will change to Emission, and the device will make a continuous beeping sound.

This photo shows the panel when the foot switch is depressed all the way down and a laser is being emitted. If you depress the foot switch to first level, the spray water and air will be emitted but the laser will not.

Depress the foot switch all the way down to emit the laser.



- (5) Press the Ready Key when you finish laser emission. Check that the Ready Key goes out and the device goes to Standby mode.

3) Emergency Stop

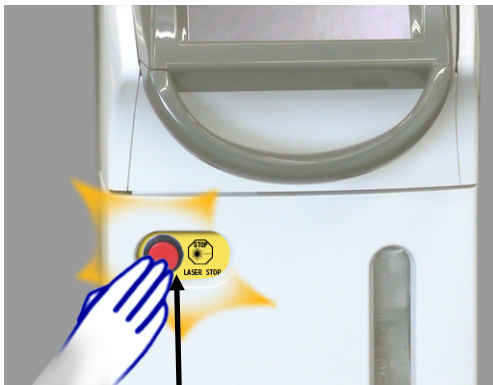

Emergency Stop Switch

(1) Emergency Stop

- In an emergency, press the Emergency Stop Switch; this will immediately stop the laser emission.

(2) Restore Operation

- Press the Start Switch to turn the device off.
- Press the Emergency Stop Switch again to release it.
- Press the Start Switch.
- The device will go into Stand-by mode if it passes the automatic self-diagnostic test.

If the device will not be restored to the safe and normal operation, or will not operate, contact your local dealer or J. MORITA OFFICE.

 **WARNING**

- *A direct, reflected or scattered laser beam can cause permanent blindness. All individuals in the laser use area must wear laser safety glasses supplied with this device. Other parts of the body should also be protected. The laser beam can cause serious injury to the skin and eyes.*
- *Even if you are wearing laser safety glasses, never look directly into the aperture where the laser comes out; there is a risk of blindness. Both the main laser and the guide light are dangerous. The laser safety glasses provides only temporary protection.*
- *Take great care to avoid overheating in the vicinity of critical tissues such as nerves and blood vessels.*
- *A pulse rate of 20 or 25 pps will tend to heat up the target area more than one of 10 pps or less. Keep this in mind to set the power and adjust the flow of the spray water.*
- *Keep combustible tubes, gases and other materials well away from the laser beam. Never irradiate a laser to combustible materials such as trachea tubes, non-woven cloth, or surgical gloves. These could suddenly ignite. Also watch out for combustible medical solutions and gases inside the patient's body.*
- *Do not inhale laser plume produced by the laser irradiation to the treatment area or get them in your eyes. Because the laser plume may contain infectious viral particles and bacteria. Use high-speed suction to remove all smoke and particulates in the laser plume. Also use clinical masks for protection.*
- *Do not use this device in the presence of a combustible anesthetic or an elevated concentration of oxygen; this could result in ignition or explosion. A laser beam will readily ignite a tracheal tube such as those made of silicon rubber in the presence of a high concentration of oxygen or an anesthetic gas mixed with oxygen. For example, a laser beam will instantly ignite the tube if the oxygen concentration is 48%.*
- *If use of oxygen is absolutely essential, the oxygen delivery tube must be protected with a non-combustible cuff and steps must be taken to insure that there is no leakage of oxygen.*

 **CAUTION**

- *The output depends on the diameter of the contact tip; a larger diameter will deliver more energy. Keep this in mind to make irradiation settings.*
- *This device must not be used for any purpose other than vaporization, coagulation, hemostasis and resection of biological tissues. Never irradiate the laser to anything except the treatment area.*
- *Handle contact tips with great care; they break easily. A piece of a broken contact tip could cut the patient and cause bleeding or might be left in the tissue being treated. Never bend or apply force to the contact tip. Contact tips with a small fiber diameter are especially delicate and will break very easily if some force is applied to the part coming out of the pipe. Use a rubber dam if there is a case that the contact tip might get broken during treatment.*
- *Before irradiating the laser, check the aim with the guide light or by touching the target with the contact tip.*
- *Never irradiate the laser on prosthetic devices, mirrors or anything that will reflect it or scatter it. Cover the treatment area with damp gauze or find some other way to avoid the risk of reflected laser.*
- *Always leave this device in Stand-by mode when it is not required to emit the laser.*

4) Memory

20 combinations of settings can be saved and restored.

Press the Memory key on the Main panel to go to Memory Display Panel to show the saved settings.

Memory Display Panel

Group Tabs

There are 4 groups of memories, each of which has 5 sets of memorized settings, for a total of 20 sets of settings.

The name of the group tab can be changed for your convenience.

The background color of the previously selected setting is different from others.

Memorized Keys

There are 5 Memorized Keys for each group. Press the key to restore the memorized setting.

Memory Name

Each Memorized Key can be named for your convenience.

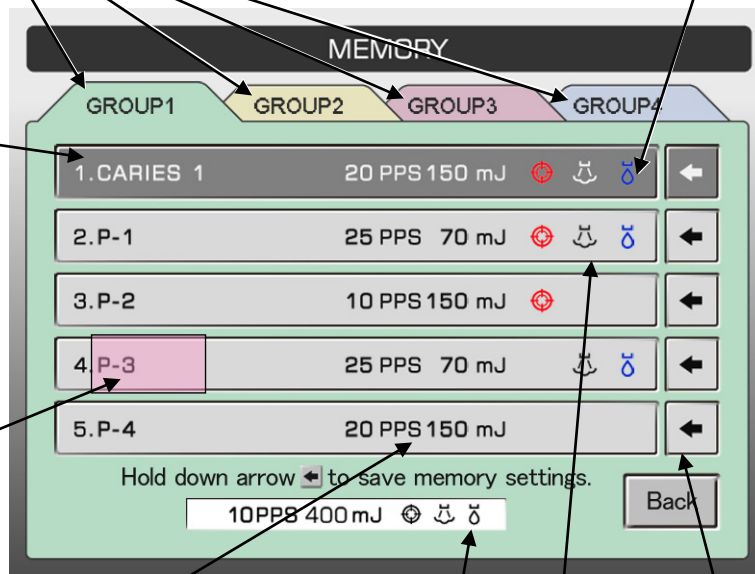

Settings

The saved setting is shown on the Memorized Key.

Current Setting

Memorize Keys

Hold down one of the Memorize Keys to save the current setting.

Icons for Aiming, Air, and Spray Water

The icon appears if the associated function is turned on.

Restoring Memory

(1) Press the Memory key to go to the Memory Display Panel.



(2) Press the group tab to use.

(3) Press the memorized key to restore.

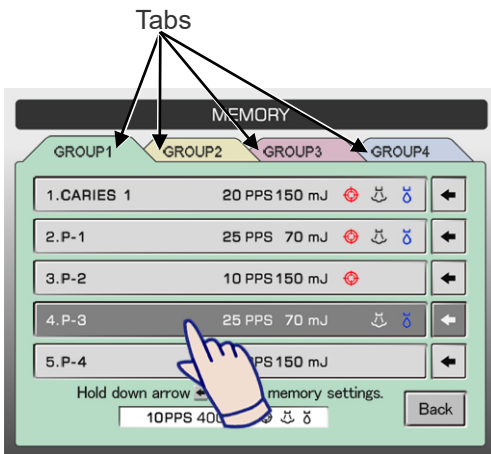

Press the memorized key

(4) The selected setting is restored.

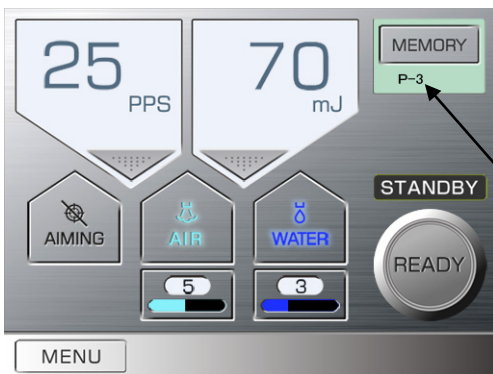

Memory Name
(Up to 8 characters)

⚠ CAUTION

- *Always check settings before using the device.*

Saving New Setting



- (1) Display the desired setting on the Main panel.
- (2) Press the Memory Key to go to the Memory Display Panel.

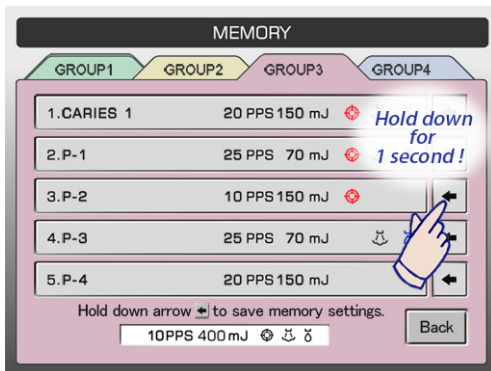

- (3) Hold down a Memorize Key for a memory for 1 second.

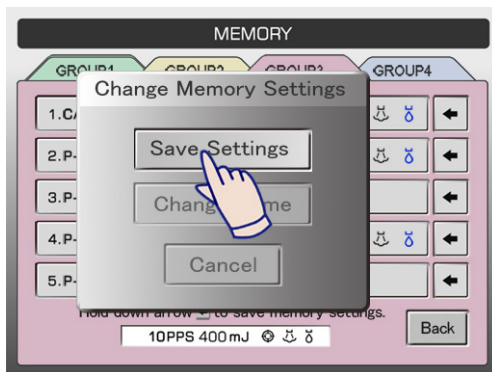

- (4) A pop-up menu will appear. Press the Save Setting.

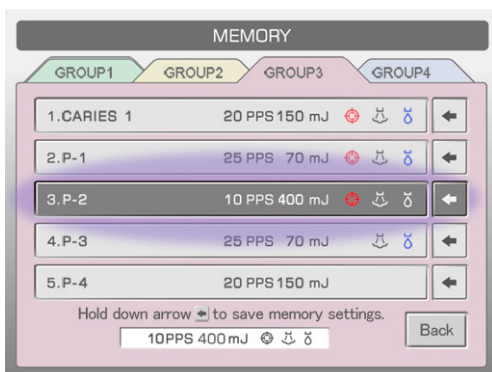

- (5) The new setting combination is now saved.

Changing Memory Name

(1) Press the Memory Key to go to the Memory Display Panel.

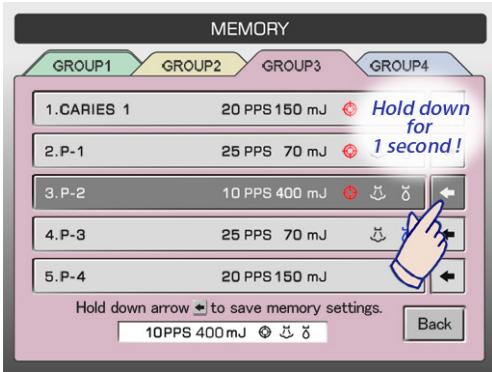

(2) Hold down the Memorize Key for the memory for 1 second.

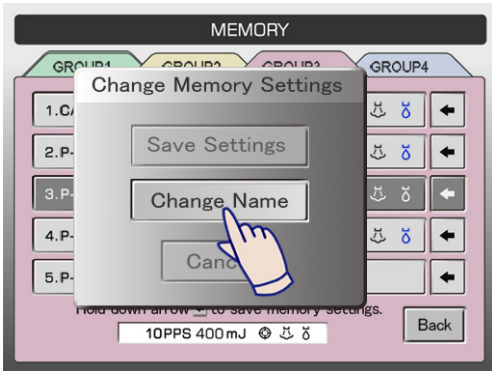

(3) A pop-up menu will appear. Press Change Name.

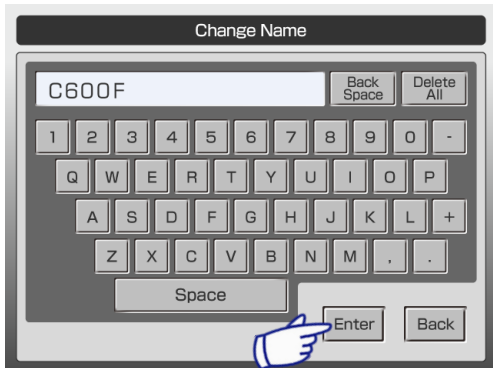

(4) A keyboard will appear. Enter the desired name. You may use up to 10 characters. Press Back Space to erase the last character. Press Delete All to erase the whole field.



(5) Press Enter to complete the name change. Changing the name will not change any of the settings for that memory.

Changing Group Tab Name

Name the tabs for your convenience.

- (1) Press the Memory Key to go to the Memory Display Panel.



- (2) Hold down the Tab for the name change for 3 seconds.

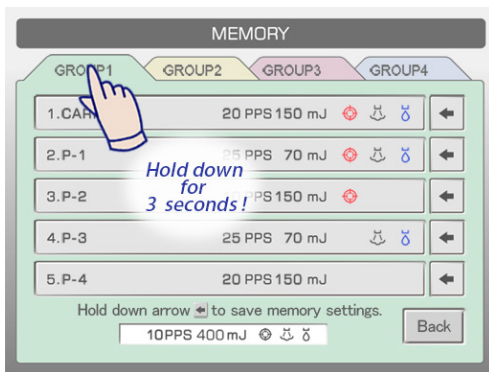

- (3) A keyboard will appear. Enter the desired name. You may use up to 6 characters. Press Back Space to erase the last character. Press Delete All to erase the whole field.

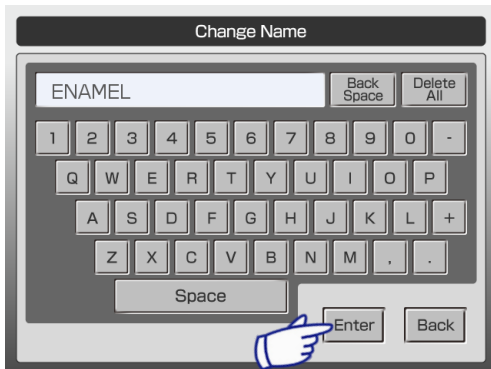

- (4) Press Enter to complete the name change.

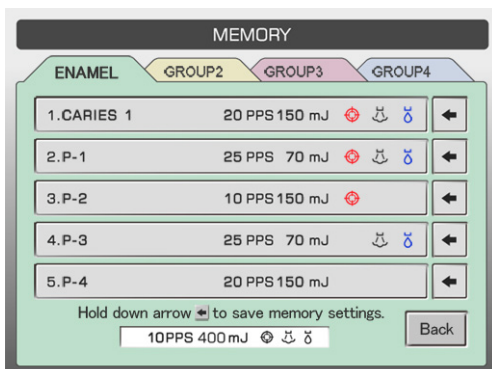

(5) Stopping Device



- (1) Check if the device is in Standby mode.
If it is in Ready mode, press the Ready key.
The Ready Key will go out and the device will go into Standby mode.

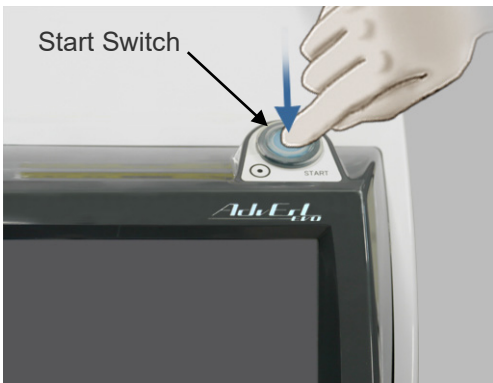

- (2) Press the Start switch.
The device will turn off.

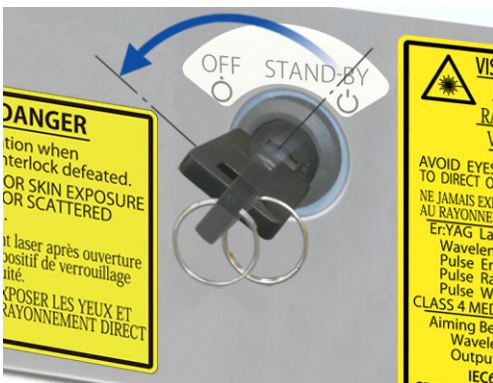

- (3) Turn the key off.
- (4) Remove the key and return it to a supervisor.



- (5) Turn off the circuit protector at the bottom of the back of the Main unit.

(6) Moving Device



- (1) Hang the foot switch on the hook on the rear of the device.
- (2) Push the handpiece hanger back and put the handpiece in it.
 1. Push down the ring on the joint.
 2. Push the hanger back.
- (3) Use the front or rear handle to move the device.

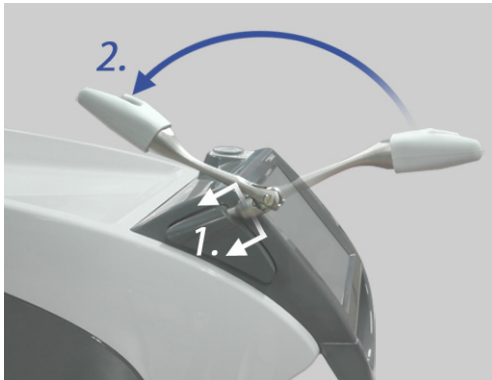

NOTE

- ◆ *Do not leave the handpiece in the hanger when pushing the hanger back; it could fall out.*
- ◆ *Remove the contact tip before moving this device; it could get broken.*
- ◆ *Never push or pull on the hollow waveguide support or the handpiece hanger.*



WARNING

Risk of overbalance;

- *Do not push side of the equipment to prevent any unwanted movement.*
- *When moving the device on a slope, lock the front casters and lock the rear wheels by using the wheel locking device.*

CAUTION

- *When passing over threshold, go from backside first.*
- *Push rear end first to go over bumps.*

(7) Making Other Setting and Checking Information



Hold down the Menu key.

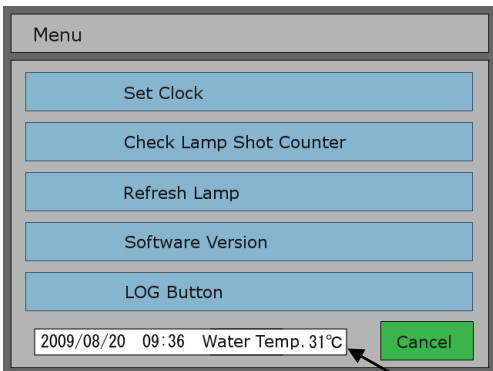

The Menu will appear.

Press the key for the category you wish to view.

The clock and temperature of the cooling water appear here.
Water temperature range for operation:
15 – 45 °C (59 – 113 °F).

Set Clock

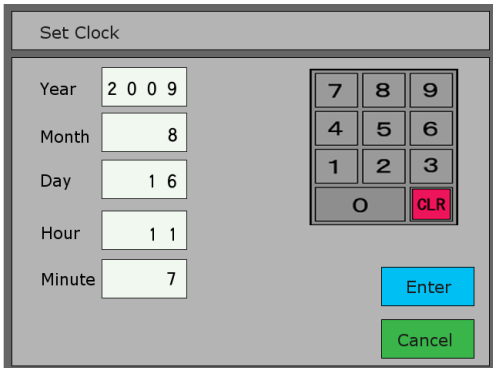

Select Year, Month, Day, Hour, or Minute and then use the numeric keyboard to enter the number. Press Enter to finish.

Check Lamp Shot Counter

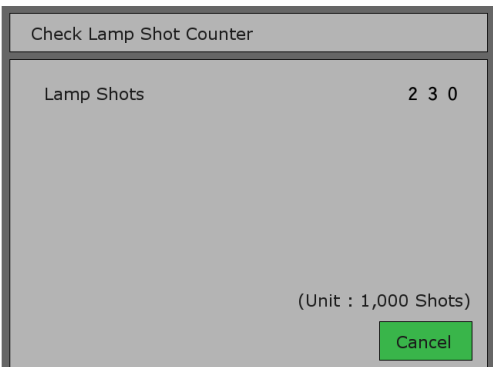

Check the total number of shots for the flash lamp. See page 49.

Refresh Lamp

After considerable use, the condition of flash lamp may get worse, no longer work well, and cause errors to occur. (Interlock 1 or error 104)
The procedure described below may rectify the problem. It takes about 15 minutes.

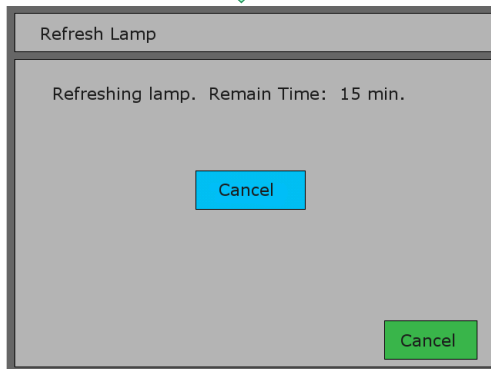
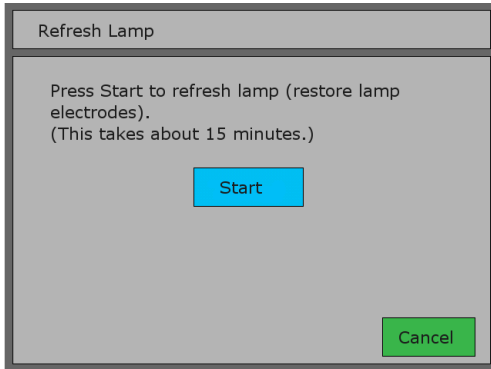

If the device is used at low power for a long time, the terminals of flash lamp may get dirty and interfere with ignition. Operating the flash lamp at high power by executing the “Refresh Lamp” will clean up the terminals.
The procedure stops after 15 minutes or you can stop it anytime by pressing Cancel.

Check Software Version

Check the software versions for the control system, display, and screen.

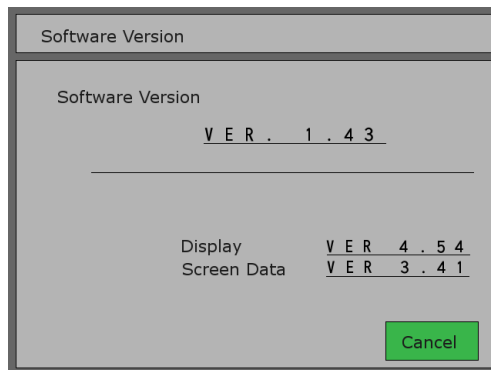

LOG Button

Use the LOG Button to show or hide the Log key on the Main panel.

Select the “ON” state to show the Log key.
Use the Up and Down key to switch to “ON” and “Off” and then press Enter.

The default setting is the “Off” state.

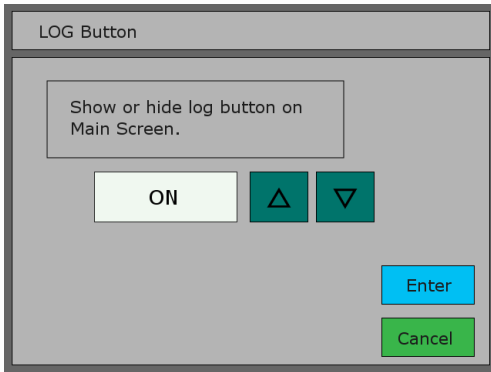

The Log key appears on the Main panel when it is in the “ON” state.

(2) USB Flash Drives

The format for USB flash drive must be at least FAT16/32, 128 MB.

Some USB flash drives may not recognize the log data.

NOTE

- ◆ *Some USB flash drives have a format that will not recognize the data. These can be reformatted using Windows. (All data will be lost when the USB flash drive is reformatted.)*
- ◆ *Never take the USB flash drive out while data is being copied onto it. This could destroy all the data on the flash drive. You can take the USB flash drive out anytime data is NOT being copied onto it.*

Data Transfer Preparation

Press the LOG Key. If the LOG Key is not displayed, go to the Menu to enable the LOG Key function.

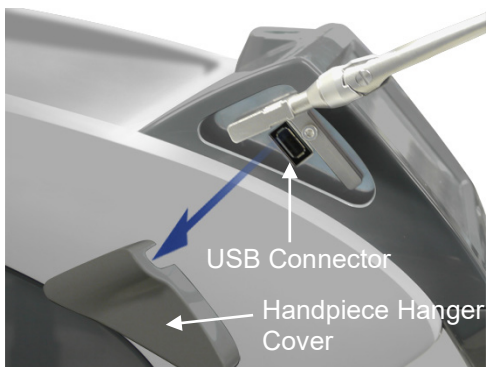

(3) Copy Data to USB Flash Drive

- Take off the handpiece hanger cover.
- Plug a USB flash drive in.

- If the USB flash drive is recognized, "OK" will appear in the display. Press the "Download to USB" key.

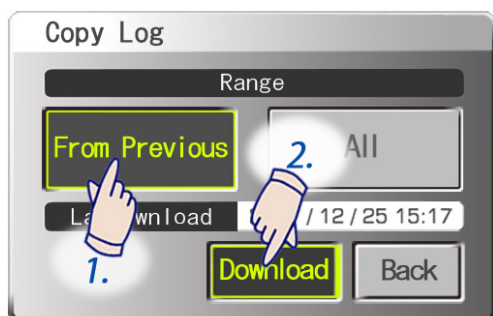
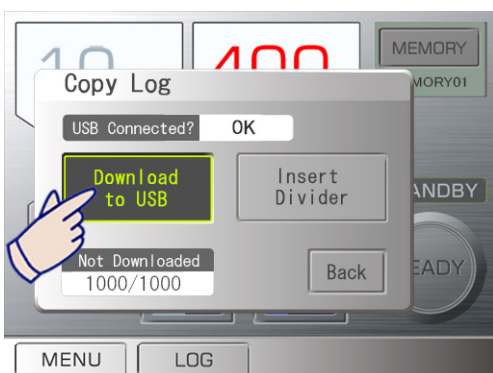

- Specify the Part for Copying
Press "From Previous" to copy the part of the log created since the last time it was copied.
Press "All" to copy the whole log (up to 1,000 records).
Then press the Download key.



- Press the Download key; the data will then be copied onto the USB flash drive.

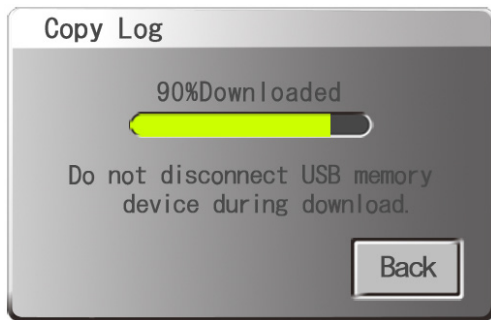

- A progress bar will show how much has been copied so far.

- Never unplug the USB flash drive while data is being copied onto it; this could destroy all the data.
- After all the data has been copied to the USB flash drive, press the Back key and pull the USB flash drive out.
- Press the “Back” key.
- If the copy procedure stops before finishing, press the Back key and do it again.

(3)-1 Put Dividers in Log Record

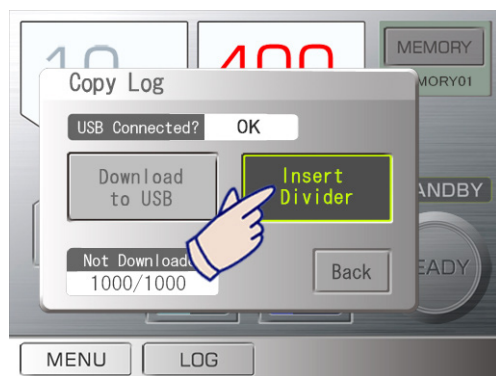

- Divider lines can be put in the log.
- These can be put in between patients or types of treatment for your later convenience.
- Press the Log key and then press the Insert Divider key. A divider will be inserted each time you press the key.

(3)-2 Number of Log Records

Out of a maximum of 1,000 records, the number of log records not yet copied is shown.

The Log key will start blinking after this number has exceeded 900.

(4) Data Files

The data files will be saved in the folder named “MEY1LOG” on a USB flash drive. This folder is created automatically.

MEY1LOG Folder and its Contents

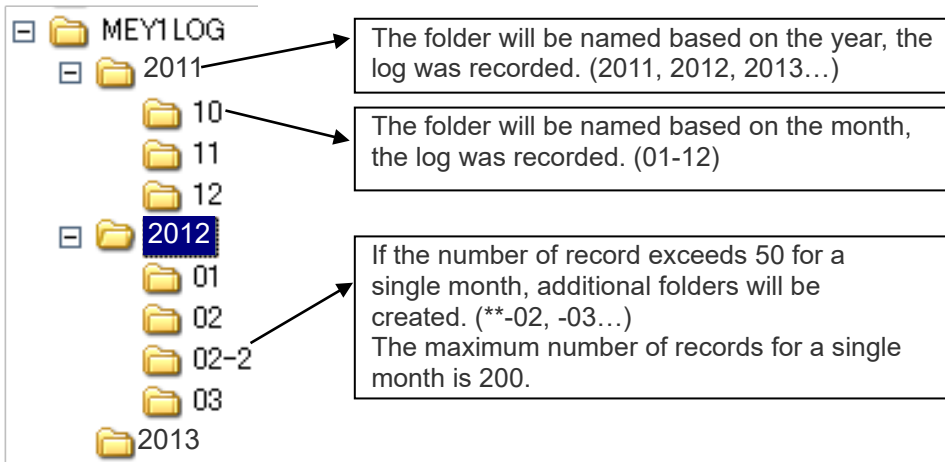

The log file, named such as “0715-01.csv”, will be saved inside the folders. 0715-01.csv, for example, July 15th consecutive number in a single day (01, 02, 03...)

- * The date used in the file name is the date the file was copied.
- * CSV files are the text files. These can be used with software applications such as Microsoft Excel.

NOTE

- ◆ *Periodically back up all data so that it cannot be accidentally lost.*
- ◆ *If there is a power failure while data is being copied onto the USB flash drive, all the files on the USB flash drive could be lost. Do not keep any other important files on the USB flash drive.*

4. Sterilization, Replacement Parts, and Storage

⚠ WARNING

- *To prevent the spread of serious, life-threatening infections, the handpiece grip and its hanger, contact tips and tip stand must be cleaned and sterilized between patients.*
- *All the handpiece grip and its hanger, contact tips and tip stand are delivered in non-sterile condition. Clean and sterilize them prior to initial use.*

<All information about cleaning and sterilization (Autoclaving) >

	Cleaning and Sterilization	Detail
Contact Tips	Immerse the contact tip fiber in tap water and emit the laser. Use the enzymatic detergent (CIDEZYME Johnson & Johnson company: for example) to clean off blood and other contaminants. ↓ Immerse the contact tip in an available chemical disinfectant ↓ • Chlorhexidine Gluconate • Ethanol (70 vol% to 80 vol%) ↓ Autoclaving (+135°C (+275°F) 10 to 15 min)	Refer to pp. 42-43
Handpiece Grip	Wipe entire handpiece grip outer surface with a soft cloth and ethanol (70 vol% to 80 vol%). ↓ Autoclaving (+135°C (+275°F) 10 to 15 min)	Refer to pp. 42-43
Hanger	Wipe the hanger with a soft cloth and ethanol (70 vol% to 80 vol%). ↓ Autoclaving (+135°C (+275°F) 10 to 15 min)	Refer to pp. 42-43
Tip stand	Wipe the tip stand with a soft cloth and ethanol (70 vol% to 80 vol%). ↓ Autoclaving (+135°C (+275°F) 10 to 15 min)	Refer to pp. 42-43

	Cleaning only	Detail
Main unit	Wipe the outside of the main unit with ethanol (70 vol% to 80 vol%) or neutral detergent	Refer to p. 44

(1) Handpiece Grip, Hanger, Contact Tips and Tip stand Cleaning and Sterilization

1) Cleaning (Always perform this procedure prior to sterilization)

The cleaning process is intended to remove blood, protein and other potential contaminants from contact tips, handpiece grip and hanger. This will not sterilize them. Contamination control should be performed by trained personnel, while wearing protective gear (including masks gloves and shields).

<Contact Tip>

- (1) After using the contact tip, immerse the fiber part of the contact tip in tap water and emit the laser for 3 to 5 seconds. If there are many contaminants, emit the laser for 20 to 30 seconds. (Recommended setting is 25 PPS 50 mJ Air 10 Water 7)
- (2) Use the enzymatic detergent (CIDEZYME Johnson & Johnson company: for example) by the detergent's manufacturer's directions to clean off blood and other contaminants.
- (3) Immerse the contact tip in an available chemical disinfectant for recommended time by the disinfectant's manufacturer's directions.
Use one of the disinfectants listed below at the concentration specified for medical instruments for cleaning solution.
 - **Chlorhexidine Gluconate (Hibiten, for example)**
 - **Ethanol (70 vol% to 80 vol%)**
- (4) Wash the contact tip thoroughly with tap water after using the cleaning solution.
- (5) Wipe the contact tip with cotton.

NOTE

- ◆ *Do not use ultrasonic washer to clean the contact tip as it may chip the contact tip or remove the adhesive.*
- ◆ *When wiping the contact tip with a cotton, be careful as the fiber may come off if you pull the fiber with a strong force.*
- ◆ *Contact tips are consumables. If a contact tip is damaged or cannot be cleaned adequately, replace it with a new one.*
- ◆ *Do not use washer disinfectors.*

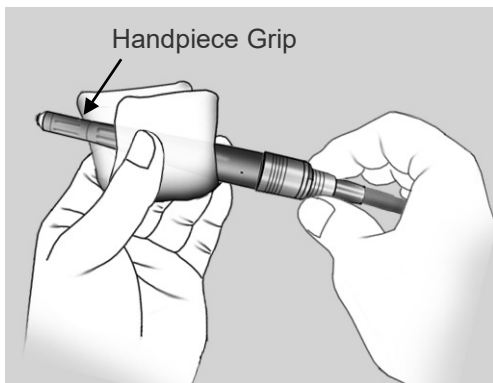

<Handpiece Grip>

Wipe entire handpiece grip outer surface with a soft cloth dampened with ethanol (70 vol% to 80 vol%).

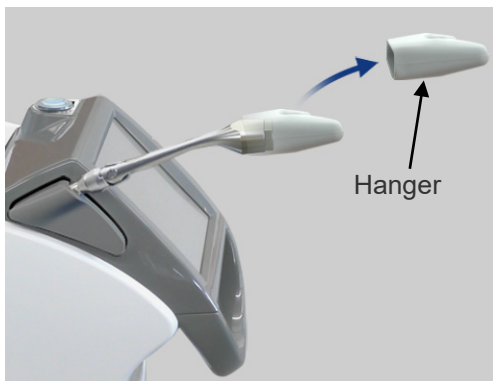

<Hanger>

- (1) Take the hanger off its arm.
- (2) Wipe entire hanger outer surface with a soft cloth dampened with ethanol (70 vol% to 80 vol%).

<Tip Stand>

Wipe entire tip stand outer surface with a soft cloth dampened with ethanol (70 vol% to 80 vol%).

2) Autoclaving (sterilization) (Always perform this procedure after cleaning and before use)

The autoclaving process is intended to destroy infectious microorganisms and pathogens.

NOTE

- ◆ *Do not perform sterilizations other than the autoclave sterilization.*

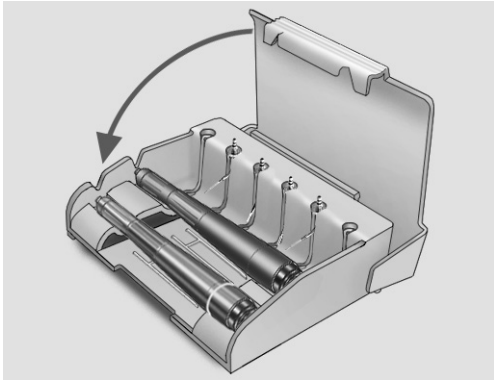

- (1) Put the handpiece grip, hanger and contact tips in sterilization pouches or the tip stand for autoclaving.

NOTE

- ◆ *When using the tip stand, the contact tip could be damaged by closing the top of the tip stand, if the contact tip is sticking up.*

- (2) Place them inside the autoclave chamber.

NOTE

- ◆ *Contact tips are easily broken. Take care that contact tips do not bump against each other or against other instruments when putting them into the autoclave. Do not drop or bump them against anything when handling them.*

- (3) Set autoclave cycle to the following parameters:

Temperature: +135°C (+275°F)

Time: 10 to 15 minutes

Dry Time: 0 min (dry naturally)

NOTE

- ◆ *Do not use the drying stage if the autoclave has one. The temperature might be too high.*

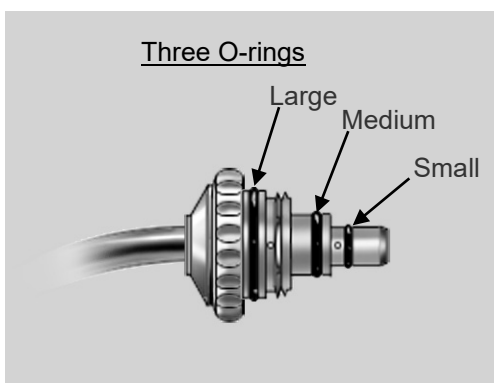

- (4) At the time of completion of the autoclave, let them cool.

NOTE

- ◆ *Make sure all 3 O-rings of contact tips are intact and not damaged in any way. Pay special attention to the smallest one. If this is missing or damaged, water could seep into the handpiece and damage it or cause the laser to lose power. It also might harm the drum lens.*

(2) Cleaning the Main Unit

Wipe the outside of the Main unit with ethanol (70 vol% to 80 vol%) or a neutral detergent.

- Immediately wipe off any chemicals that are spilled on the unit with ethanol (70 vol% to 80 vol%).

WARNING

- Always turn off the key and the circuit protector before cleaning. This will avoid the risk of burns and electric shocks as well as accidents that could result from accidentally pressing a switch.

CAUTION

- Prevent contagion and contamination by cleaning the unit regularly.

NOTE

- ◆ Do not use ozone or ultra violet light to disinfect the clinic. This could damage this device (plastic, rubber or other materials).
- ◆ Use only ethanol (70 vol% to 80 vol%) or a neutral detergent. Alkaline and acidic cleaners, liquid cresol soap, and other chemicals may damage or discolor the surface. Do not use solutions that contain cresols, triclosan, hypochlorite, aldehydes. (Check the ingredients for disinfectants.)
- ◆ Do not press down too hard to wipe the surface; this could cause peeling.

(3) Maintenance

For optimum performance follow the maintenance procedures described below.

1) Grease Handpiece

Grease the handpiece every day before use or after putting handpiece grip on and taking it off more than 50 times. The O-rings will be damaged if they are not properly lubricated and this can lead to water and air leakage inside the handpiece grip.

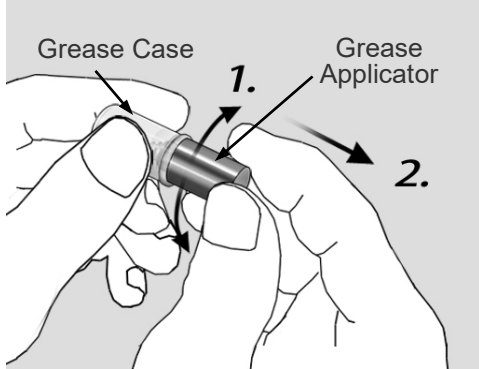

- (1) Rotate the grease applicator to apply grease (lubricating oil) to the end of the grease applicator.

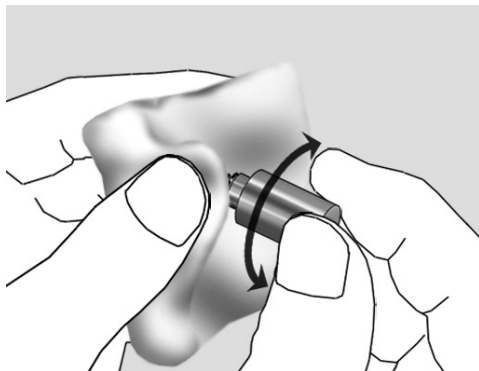

- (2) Wipe the end of the grease applicator including O-ring with gauze to remove excess grease.

* Even if the grease applicator is wiped off with gauze, there is enough grease on the handpiece side.



NOTE

- ♦ *Carefully remove all the grease on the end of the grease applicator; otherwise it might get on the drum lens inside the handpiece.*

(If any grease accidentally gets on the drum lens, wipe it off with a piece of cotton dampened with ethanol (70 vol% to 80 vol%))

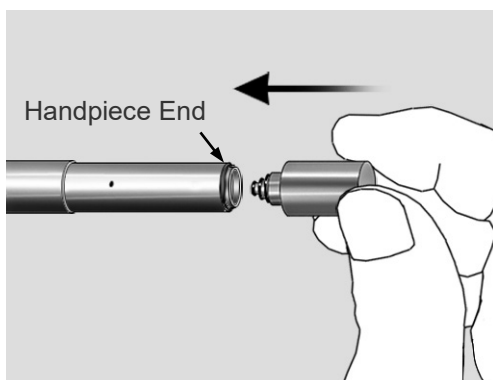

- (3) Insert the grease applicator into the handpiece as far as it will go and rotate it; then take it out. Put the grease applicator back in its case when you are finished using it.

2) Lens Cleaning

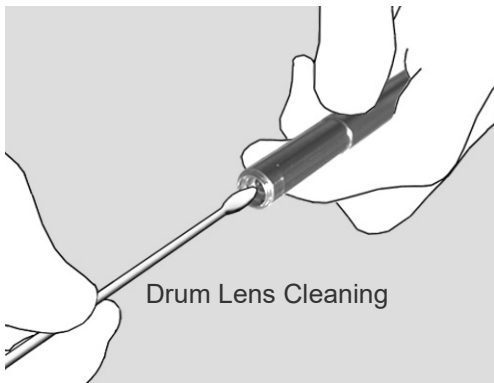

<< Drum Lens >>

Disconnect the handpiece grip and clean the drum lens on the end of the handpiece with the lens cleaner provided.

Dampen the end of the lens cleaner with ethanol or isopropyl alcohol ($\geq 70\%$) and lightly wipe the lens with it.

The recommended is ethanol ($\geq 99\%$) or isopropyl alcohol ($\geq 99\%$)

Make sure that no stain or dirt remains on the lens surface.

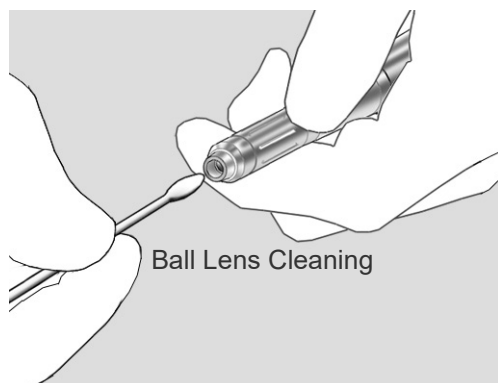
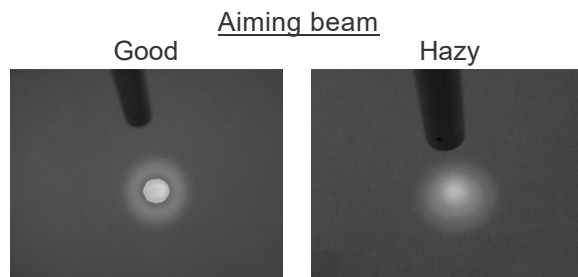

<< Ball Lens >>

Clean the ball lens on the end of the R Handpiece grip after each patient.

Dampen the end of the lens cleaner with ethanol or isopropyl alcohol ($\geq 70\%$) and lightly wipe the lens with it.

The recommended is ethanol ($\geq 99\%$) or isopropyl alcohol ($\geq 99\%$)

Make sure that no stain or dirt remains on the lens surface.

NOTE

- ◆ *Use only the dedicated lens cleaner provided to clean the drum and ball lenses*
- ◆ *If the aiming beam is hazy even after cleaning the drum lenses, these lenses might need to be replaced. In this case, contact your local dealer or J. MORITA OFFICE.*

3) Spray Water Bottle (Sterile Water for Spray) Replacement



Before using the device, check the level of the spray water bottle. Replace the bottle when the remaining water in the bottle is low.

If air gets in the tube when the bottle is replaced, depress the foot switch to its first level to force the air out.

NOTE

- ◆ *Do not step on the foot switch before connecting the tube to the spray water bottle. This will cause the pump to start up and could damage the tube.*
- ◆ *Do not pinch the water tube when you close the front door.*

⚠ CAUTION

- *Use only sterile water. Do not use tap water or saline solution.*
- *Do not pinch your fingers when you close the front door.*

(4) Storage

- (1) After using the device, turn off the key switch and the circuit protector.
- (2) Take out the key and give it to a supervisor.
- (3) Lock the casters.
- (4) Take the contact tip off the handpiece after use and keep it clean.
- (5) The device must be level and not subject to vibrations or bumping.
- (6) Store the device where it will not get wet.
- (7) If the device has not been used for 3 months, check that it operates normally before using it again.
- (8) Storage Environments
 - Temperature: +5°C to +40°C (+41°F to +104°F)
 - Humidity: 10% to 85% (without condensation)
 - Atmospheric Pressure: 70 kPa to 106 kPa.

⚠ WARNING

- **Store contact tips safely and securely in a place where they will not be accidentally swallowed.**

NOTE

- ◆ **Storage area must not be subject to freezing. If the water freezes, the resulting expansion will ruin this device.**
- ◆ **Even if this device is not being used, turn it on and circulate the cooling water once a month. This will filter the cooling water and keep it from degrading.**
- ◆ **Charge the backup battery once every 6 months. Leave the key switch off and turn on the circuit protector and start switch. Leave this device in this state for 8 hours. (Never turn the key switch to the Standby position when there is no cooling water inside. This will damage the pump.)**



About Tip Cases

- The tip case is designed for transportation purpose only until the contact tip is used. Remove the contact tip from the tip case and store it, and dispose of the tip case (it can be treated as waste plastic).
- Store the tips cases in a cool, dark place which is well ventilated. Avoid high temperatures, humidity, exposure to direct sunlight and proximity to sources of ignition.
- Tip cases that are made with biodegradable plastic are identified with a logo, shown to the right, inside the case.
- Tip cases that are made of environmentally-friendly biodegradable plastic are easily degraded by humidity, alcohol fumes and similar air-borne substances.



(5) Replacement Parts

- * Replace the cooling water once a year.
- * Replace the deionization filter cartridge once a year.
- * We recommend replacing the flash lamp after it has exceeded 10,000,000 shots; after this, errors may occur. After 20,000,000 shots, the lamp is at the end of its working life and must be replaced; otherwise, various errors will occur with increasing frequency. See page 34 for how to check the total number of shots for the flash lamp by using the Menu.
- * Order parts through your local dealer or J. MORITA OFFICE.

5. Installation

⚠ WARNING

- *Never assemble or disassemble the device in any way other than specified in this Instructions for Use.*

⚠ CAUTION

- *Do not apply excessive force or stress to the hollow waveguide. Never bend it into a curve with a radius of less than 6 cm.*
- *Do not put this device on a surface that is not level; it could tip over. Make sure the brakes on the casters are locked.*
- *Never tilt this device more than 10° when moving it; it could tip over.*
- *Do not fail to connect the ground lead.*
- *Use only at the specified voltage. Connecting this device to the wrong voltage could damage the device and also cause smoke or a fire.*
- *When moving the device, keep a safe distance away from the casters and wheels to avoid entanglement of fingers or clothes, etc.*

The AdvErL EVO must be installed with a qualified employee or representative; refer to “Installation Instructions” for setup instructions.

< Cautionary Remarks on Installation >

- Electrical Supply Requirement 100 VAC 15 Amps to 240 V 7 Amps 50/60 Hz
- Never cover or block the ventilation opening with anything.
- Use this device in a specially designated area and identify the area clearly with a sign by using Bundled danger plate” or “warning plate”.

NOTE

- ◆ *Keep this device where the cooling water will never freeze.*

1) Water Tube



If the water tube is not connected to the spray water connector, plug it in until it clicks into place.

2) Foot Switch

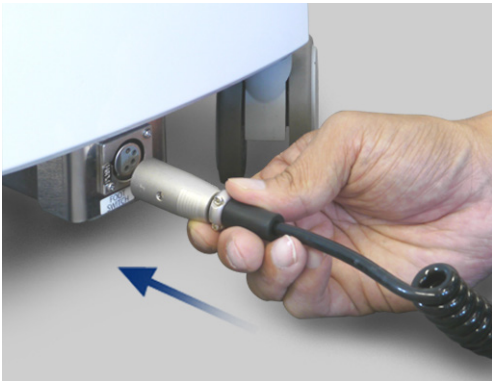

Plug the cord for the foot switch into its mate on the Main unit. Make sure it clicks securely into place.

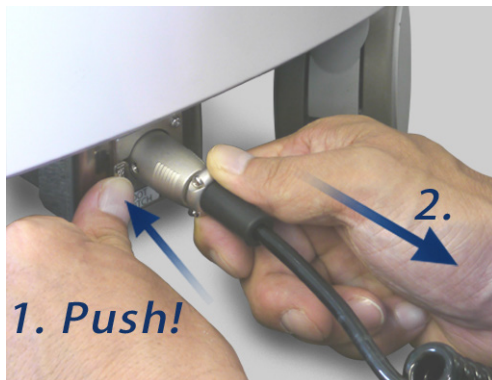

- * To unplug it, push the lever in to unlock it and then pull it out.

NOTE

- ◆ *To avoid breaking the cable wire or damaging the connectors, pay attention to the following points:*
 - *Do not give a strong tug or apply excessive force to the foot switch cable or remote interlock connector.*
 - *Make sure that the connector does not make contact with bumps on the floor when moving this device to avoid getting the cable caught in the casters.*

3) Remote Interlock Connector

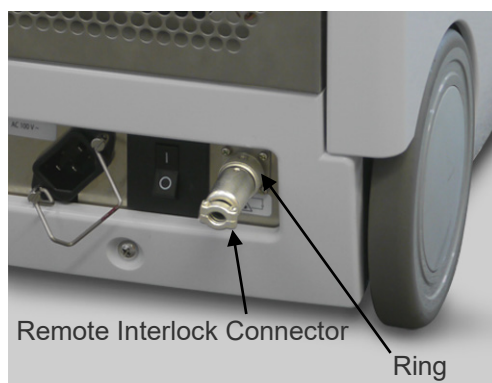

- The remote interlock connector is on the back of Main unit. The remote interlock connector is internally shorted.
- It can be used in various ways to enhance safety and avoid risk.
 - * Emergency shut down
 - * Door interlock
 - * Other interlock functions

Plug in the connector and turn the ring to secure it.

6. Annual Maintenance, Inspection and Calibration

WARNING

- *This device must not be taken apart by anyone except for specially trained MORITA service personnel. High voltage circuits inside the Main unit could cause death by electric shock. For disassembly and servicing, rely only on J. MORITA OFFICE personnel.*

CAUTION

- *Check laser output annually.*
- *Laser can be emitted from the laser aperture when the top cover is opened and interlock is defeated. Never look into or touch the laser aperture.*

Annual Maintenance

- * The AdvErL EVO should be maintained annually in accordance with the following maintenance and inspection items.
Maintenance should be done by specially trained service personnel.

1) Outline

- Screw Tightness of all screws, bolts etc.
- Floor level and casters are stable
- Main Power Supply Within: 100 V to 240 V $\pm 10\%$
- Electric Circuits wiring and Cables for foot switch and power.

2) Function Check (Interlock)

- Emergency Stop
- Hollow Waveguide disconnected.
- Remote Interlock connector disconnected.
- Interlock messages are not displayed before use
- Foot Switch
- Key Switch
- Spray Water
- Tip Air

3) Replacement

- Cooling water and Deionization Filter Cartridge
Replace all the cooling water and deionization filter cartridge.
- Flash Lamp
Check the total number of shots of flash lamp. Replace after 10 million shots. (recommended)

4) Other Parts

- Aiming beam emission
- Laser Safety Glasses are not damaged.
- Contact tips are not damaged or dirty.
- Handpiece O-ring
- Handpiece is securely attached

5) Calibration of Laser Output

- Laser Output Level
Output level is $\pm 20\%$ of displayed value.
Calibration is to be performed only by a trained service engineer.

- * For repair or other types of service contact your local dealer or J. MORITA OFFICE.

7. Clinical Applications

(1) Introduction

The AdvErL EVO Laser System is intended for use only by dentists trained in the safe handling of the laser. Please read and understand this Instructions for Use, and use the laser system in vitro prior to using it on patients. Observe all of the safety precautions described in this Instructions for Use. Hygienists or other health professionals handling lasers should also read and understand this Instructions for Use of the system.

(2) Er:YAG Laser Ablation

2.1) Tissue Interaction

AdvErL EVO is an Er:YAG laser system.

Er:YAG is Erbium doped Yttrium Aluminum Garnet crystal, and system generate 2.94 μm laser.

It was selected because the wavelength matches the vibrational absorption of water molecules in the tissue. Figure 1 shows that absorption coefficient of water.

Er:YAG laser wavelength (2.94 μm) is near the peak of absorption coefficient of water.

When the laser is absorbed by tissues, it excites the movement of tissue molecules and causes tissue coagulation and vaporization, in both hard and soft oral tissues.

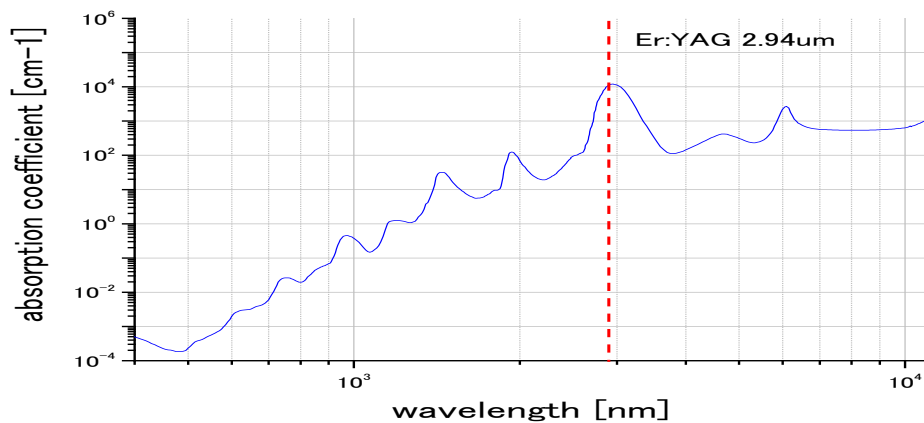

Figure 1 Absorption coefficient of water.

[Data from D. J. Segelstein, "The complex refractive index of water", University of Missouri-Kansas City, (1981)]

2.2) Parameter of Laser Ablation

There are many important parameters for laser ablation procedures.

Parameter of laser output, such as pulse frequency, energy density, total irradiation time, etc., parameters of contact tip, such as diameter and distance from the tissues, are all important for the laser ablation procedure. For more detail, see later section.

■Reference

- | | |
|---|--------------------|
| 1) Tissue Ablation: Devices and Procedures | John. G XVeberster |
| 2) Dent. Clin. N. Am. 48 (2004)1017-1059 | Glenn van As |
| 3) Laser-Tissue Interactions: Fundamentals and Applications | Markolf H. Niemz |

(3) Warnings and Notes

Never use this device for patients who have a pacemaker or an implantable cardioverter defibrillator (ICD); it could cause these devices to operate erratically.

Tip Air

Take great care when using the tip air inside a body cavity or tubular lumen. Raising the air pressure inside a cavity or lumen could force air into a blood vessel through an open wound and result in an air embolism. Also take great care when using the tip air in areas of the oral cavity where it could increase the pressure; this could result in a severe air embolism or subcutaneous emphysema.

Combustion Danger due to Elevated Level of Oxygen

Do not use this device in the presence of a combustible anesthetic or an elevated concentration of oxygen; this could result in ignition or explosion. A laser beam will readily ignite a tracheal tube such as those made of silicon rubber in the presence of a high concentration of oxygen or an anesthetic gas mixed with oxygen. For example, a laser beam will instantly ignite the tube if the oxygen concentration is 48%. If use of oxygen is absolutely essential, the oxygen delivery tube must be protected with a non-combustible cuff and steps must be taken to insure that there is no leakage of oxygen.

A direct, reflected or scattered laser beam can cause permanent blindness. All individuals in the laser use area must wear laser safety glasses supplied with this device. Other parts of the body should also be protected. The laser beam can cause serious injury to the skin and eyes. Even if you are wearing laser safety glasses, never look directly into the aperture where the laser comes out; there is a risk of blindness. Both the main laser and the guide light are dangerous. The laser safety glasses provides only temporary protection.

Read and understand all safety Warnings and Precautions described in the each section.

(4) Adverse Effects

There are no known adverse effects in treating soft or hard tissue applications.

(5) AdvErL EVO INTENDED FOR USE

Use of AdvErL EVO is intended for:

Hard Tissue General Indications*

- Class I, II, III, IV and V cavity preparation
 - Caries removal
 - Hard tissue surface roughening or etching
 - Enameloplasty, excavation of pits and fissures for placement of sealants
- * For use on adult and pediatric patients

Root Canal Hard Tissue Indications

- Tooth preparation to obtain access to root canal
- Root canal preparation including enlargement
- Root canal debridement and cleaning

Bone Surgical Indications

- Cutting, shaving, contouring and resection of oral osseous tissues (bone)
- Osteotomy

Endodontic Surgery (Root Amputation) Indications

- Flap preparation – incision of soft tissue to prepare a flap and expose the bone.
- Cutting bone to prepare a window access to the apex (apices) of the root(s).
- Apicoectomy – amputation of the root end.
- Root end preparation for retrofill amalgam or composite.
- Removal of pathological tissues (i.e., cysts, neoplasm or abscess) and hyperplastic tissues (i.e., granulation tissue) from around the apex

NOTE

- ♦ *Any tissue growth (i.e., cyst, neoplasm or other lesions) must be submitted to a qualified laboratory for histopathological evaluation.*

Laser Periodontal Procedures

- Full thickness flap
- Partial thickness flap
- Split thickness flap
- Laser soft tissue curettage
- Laser removal of diseased, infected, inflamed and necrosed soft tissue within the periodontal pocket
- Removal of highly inflamed edematous tissue affected by bacteria penetration of the pocket lining and junctional epithelium
- Removal of granulation tissue from bony defects
- Sulcular debridement (removal of diseased, infected, inflamed or necrosed soft tissue in the periodontal pocket to improve clinical indices including gingival index, gingival bleeding index, probe depth, attachment loss and tooth mobility)
- Osteoplasty and osseous recontouring (removal of bone to correct osseous defects and create physiological osseous contours)
- Ostectomy (resection of bone to restore bony architecture, resection of bone for grafting, etc.)
- Osseous crown lengthening
- Removal of subgingival calculus

Soft Tissue Indications including Pulpal Tissues*

Incision, excision, vaporization, ablation and coagulation of oral soft tissues, including:

- Excisional and incisional biopsies
- Exposure of unerupted teeth
- Fibroma removal
- Flap preparation – incision of soft tissue to prepare a flap and expose the bone.
- Flap preparation – incision of soft tissue to prepare a flap and expose unerupted teeth (hard and soft tissue impactions)
- Frenectomy and frenotomy
- Gingival troughing for crown impressions
- Gingivectomy
- Gingivoplasty
- Gingival incision and excision
- Hemostasis and coagulation
- Implant recovery
- Incision and drainage of abscesses
- Incision and drainage of periapical abscesses
- Laser soft tissue curettage of the post-extraction tooth sockets and the periapical area during apical surgery
- Leukoplakia
- Operculectomy
- Oral papillectomies
- Pulpotomy
- Pulp extirpation
- Pulpotomy as an adjunct to root canal therapy
- Reduction of gingival hypertrophy
- Removal of pathological tissues (i.e., cysts, neoplasm or abscess) and hyperplastic tissues (i.e., granulation tissue) from around the apex.

NOTE

- ◆ *Any tissue growth (i.e., cyst, neoplasm or other lesions) must be submitted to a qualified laboratory for histopathological evaluation.*

- Root canal debridement and cleaning
- Soft tissue crown lengthening
- Treatment of canker sores, herpetic and aphthous ulcers of the oral mucosa (USA only)
- Treatment of canker sores, and aphthous ulcers of the oral mucosa (Canada only)
- Vestibuloplasty

* For use on adult and pediatric patients

(6) Clinical Procedure

6.1) General

Begin treatment with the lowest energy possible. If more tissue reaction is desired, increase the energy level in small increments until the desired tissue effect is observed.

Stop frequently to observe the treated area and adjust the laser settings accordingly.

Patients will usually respond more favorably if lower settings are used in the beginning of the treatment.

The ablation effect of the laser energy remove the target tissue structure is not any mechanical action of the contact tip.

6.2) Tissue Effects of Er:YAG Laser

Er:YAG laser beam is well absorbed by water.

The rate of tissue removal strongly depends on the water content of the target tissue.

So the percentage of water in target tissue is very important.

Enamel has a few percentage of water, caries and healthy dentin is more than enamel, so that caries and dentin will be removed much faster than healthy enamel. Soft tissue contains water with much more percentages, and can be ablated very rapidly.

6.3) Pulse Energy (Energy Level Setting: mJ)

Pulse energy is very important because higher pulse energy is effective for tissue ablation.

The energy of pulse is varied from 30 mJ.

Under 10 Hz, the maximum energy is 400 mJ.

At 20 Hz, the maximum energy is 170 mJ.

At 25 Hz, the maximum energy is 80 mJ.

In case of using high energy per pulse settings, consider about patient discomfort and adverse effects on tissues. .

The duration of each individual pulse is a duration of approximately 300 microseconds.

This duration is very short compared to a whole second.

The time between irradiation, tissue is cooled properly with spray water.

6.4) PPS (Hz)

This is irradiation number of times in a second. The PPS setting can be adjusted from 1 to 25 Hz.

It can influence patients' comfort level.

Generally, higher PPS irradiation of tissue surface will be smooth in enamel and dentin.

In soft tissue, the finish line of the cut can be better controlled.

Lower PPS setting is better to improving patient's comfort level.

6.5) Laser Energy Density

The threshold for ablation depends not only on the energy per pulse, but also depends on the density of the energy per pulse.

When the laser energy is irradiated on tissues, a higher energy density will have a greater effect.

The laser emission from the contact tip end spreads out, as detailed at **6.6) Type of Contact tips**.

Therefore, the best cutting efficiency is achieved when the contact tip is very close to the target.

In order to get the best cutting efficiency and longest contact tip lifetimes, be separately used from the hard tissue approximately 1/2 mm.

Another, diameter of contact tip is important. Treatment by small diameter contact tips will be more effective on ablation than larger diameter tip, but irradiated area is smaller.













 **WARNING**









- *Screw the contact tip into the handpiece grip all the way on otherwise the contact tip may come off during use, causing incorrect laser irradiation or swallowing the contact tip.*

 **CAUTION**

- *Contact tips are consumable and must be replaced periodically. Inspect contact tips carefully before using them (see below). Worn contact tips could overheat and injure the patient.*
 - *Do not use chipped or worn contact tips.*
 - *Do not use contact tips if the laser output seems lower than usual.*
 - *If the guide light is dim or does not appear at all, the contact tip may be damaged.*
- *End of contact tips are sharp and can cause injury; handle them with care.*
- *Use only contact tips specified for AdvErL EVO.*
- *When putting contact tips on and taking them off, turn the key off or put this device in Stand-by mode.*
- *Always hold the knurled part of the contact tip to screw it on or off; never grip the metal pipe, which could damage the contact tip.*
- *Never emit a laser without having the handpiece and a contact tip installed.*
- *Check the end of contact tips and make sure they are free of blood and other contamination or debris. Otherwise, they might be overheated, especially if the tip air and spray water are turned off. Overheated contact tips could injure the patient.*

6.6) Type of Contact Tips

Series	Type	Outline	End Shape	Diameter (µm)	Tissue Type	Remarks
C Series 	C400F		FLAT	400	Hard Tissue Perio	
	C600F		FLAT	600	Hard Tissue Perio	
	C800F		FLAT	800	Hard Tissue Perio	
P Series 	P400FL		FLAT	400	Hard Tissue Perio	
	P400T		TAPER	400	Hard Tissue Perio	
PS Series (PERIO SURGERY TIP) 	PS400T		TAPER-FLAT	400	Hard Tissue Perio Soft Tissue	
	PS400TS		TAPER-FLAT SHORT	400	Hard Tissue Perio Soft Tissue	
	PS600T		TAPER-FLAT	600	Perio	
	PS600TS		TAPER-FLAT SHORT	600	Perio	
PSM Series 	PSM600T		FLAT	400	Perio	

Series	Type	Outline	End Shape	Diameter (μm)	Tissue Type	Remarks
S Series (SURGICAL TIP) 	S600T		TAPER	600	Soft Tissue	
R Series 	R200T		TAPER	200	Hard Tissue	*1
	R300T		TAPER	300	Hard Tissue	
	R600T		TAPER	600	Perio	
CS Series 	CS600F		FLAT	600	Hard Tissue	

*1 These contact tips require R Handpiece Grip.

6.7) Contact Tips and Treatment Settings

Irradiation target (indications)		Tip Type	PPS (Hz)	Energy Level Setting (mJ)	Remarks	
Hard Tissue	Healthy Enamel Occlusal Surface	C400F C600F C800F CS600F	10	160 – 210		
			20	160 – 170		
	Healthy Enamel Cavo Surface		20	90 – 140		
	Healthy Dentin		10 – 20	70 – 110		
			25	70 – 80		
	Caries		10 – 25	50 – 70		
	Bone		C400F C600F C800F S600T	10 – 20	30 – 100	
	Root Canal		R200 R300	10 – 25	30	
Perio	Calculus	PS400T(S) PS600T(S) P400FL P400T PSM600T R600T	20 – 25	30 – 80		
	Granulation		20	40 – 80		
			25	40 – 80		
Soft Tissue	(Incision) (Excision)	S600T	20	40 – 100		
			25	40 – 80		

Start the treatment from the lowest energy, and then gradually increase the energy to the higher setting with checking the effectiveness.

Tip type	Indications for Use	
	Hard Tissue	Soft Tissue
C Series and CS Series		
C400F	<ul style="list-style-type: none"> • Cavity preparation - • Caries removal • Hard tissue surface roughening or etching • Enameloplasty, excavation of pits and fissures for placement of sealants • Tooth preparation to obtain access to root canal • Cutting, shaving, contouring and resection of oral osseous tissues (bone) • Osteotomy • Cutting bone to prepare a window access to the apex of the root • Apicoectomy • Root end preparation for retrofill amalgam or composite • Osteoplasty and osseous recontouring • Ostectomy 	<ul style="list-style-type: none"> • Gingival troughing for crown impressions • Gingivoplasty • Hemostasis and coagulation • Implant recovery • Laser soft tissue curettage of the post-extraction tooth sockets and the periapical area during apical surgery • Leukoplakia • Oral papillectomies • Reduction of gingival hypertrophy • Removal of pathological tissues and hyperplastic tissues • Soft tissue crown lengthening • Treatment of canker sores, herpetic and aphthous ulcers of the oral mucosa • Osseous crown lengthening
C600F	Same as C400F	Same as C400F
C800F	Same as C400F	Same as C400F
CS600F	Same as C400F	Same as C400F
P Series		
P400FL	Same as C400F and P400T	Same as C400F and P400T
P400T	<ul style="list-style-type: none"> • Cutting bone to prepare a window access to the apex of the root 	<ul style="list-style-type: none"> • Removal of granulation tissue from bony defects • Sulcular debridement • Removal of subgingival calculus • Implant recovery • Removal of pathological tissues and hyperplastic tissues
PS Series		
PS400T / PS400TS	Same as PS600T	Same as PS600T
PS600T / PS600TS / PSM600T	<ul style="list-style-type: none"> • Cutting, shaving, contouring and resection of oral osseous tissues (bone) • Osteotomy • Osteoplasty and osseous recontouring • Ostectomy 	<ul style="list-style-type: none"> • Removal of granulation tissue from bony defects • Sulcular debridement • Removal of subgingival calculus • Removal of pathological tissues and hyperplastic tissues • Implant recovery • Incision and drainage of abscesses • Laser soft tissue curettage of the post-extraction tooth sockets and the periapical area during apical surgery • Laser soft tissue curettage • Laser removal of diseased, infected, inflamed and necrosed soft tissue within the periodontal pocket • Removal of highly inflamed edematous tissue affected by bacteria penetration of the pocket lining and junctional epithelium • Osseous crown lengthening

Tip type	Indications for Use	
	Hard Tissue	Soft Tissue
S Series		
S600T	<ul style="list-style-type: none"> • Cutting, shaving, contouring and resection of oral osseous tissues (bone) • Osteotomy • Cutting bone to prepare a window access to the apex of the root • Apicoectomy – amputation of the root end 	<ul style="list-style-type: none"> • Excisional and incisional biopsies • Exposure of unerupted teeth • Fibroma removal • Flap preparation • Frenectomy and frenotomy • Gingival troughing for crown impressions • Gingivoplasty • Gingival incision and excision • Hemostasis and coagulation • Incision and drainage of abscesses • Incision and drainage of periapical abscesses • Operculectomy • Oral papillectomies • Reduction of gingival hypertrophy • Removal of pathological tissues and hyperplastic tissues • Soft tissue crown lengthening • Vestibuloplasty • Flap preparation – incision of soft tissue to prepare a flap and expose the bone • Full thickness flap • Partial thickness flap • Split thickness flap
R Series		
R200T	<ul style="list-style-type: none"> • Root canal preparation including enlargement • Root canal debridement and cleaning • Pulpotomy • Pulp extirpation • Pulpotomy as an adjunct to root canal therapy 	N/A
R300T	Same as R200T	N/A
R600T	N/A	Same as P400T

(7) Bibliography

- Ando, Y., Aoki, A., Watanabe, H. and Ishikawa, I.: Bactericidal effect of Erbium YAG laser on periodontopathic bacteria. Department of Periodontology, Tokyo Medical and Dental University, Japan; *Laser Surg Med*, 19(2): 190-200, 1996.
- Aoki, A., Ishikawa, I., Yamada, T., Otsuki, M., Watanabe, H., Tagami, J., Ando, Y. and Yamamoto, H.: Comparison between Er:YAG laser and conventional technique for root caries treatment in vitro. *J Dent Res* 77(6): 1604-1414, June 1998.
- Burkes, E. J., Jr. and Hoke, J., Gomes, E. and Wolbarsht, M.: Wet versus dry enamel ablation by Er:YAG laser. *J Prosthet Dent*, 67(6): 847-851, 1992.
- Coluzzi, D. J.: Fundamentals of Dental Lasers: Science and Instruments. Chapter in *The Dental Clinics of North America: Lasers in Clinical Dentistry* (Coluzzi, DJ, Convissar, RA editors) 48 (4) 751-770. WB Saunders Co. Philadelphia, October 2004
- Cozean, C., Arcoria, C. J., Pelagalli, J. and Powell, G. L.: Dentistry for the 21st century? Erbium:YAG laser for teeth. *J Am Dent Assoc* 128(8): 1080-1087, 1997.
- Eversole, L. R., Rizoiu, I. and Kimmel, A. I.: Pulpal response to cavity preparation by an erbium, chromium:YSGG laser-powered hydrokinetic system. *J Am Dent Assoc*, 128 (8): 1099-1106, 1997.
- Fried, D., Visturi, S., Featherstone, J., Walsh, J., Seka, W., Glana, R., McCormack, S. and Wigdor, H.: Infrared radiometry of dental enamel during Er:YAG and Er:YSGG laser irradiation. *J of Biomedical Optics*, 1 (4): 455-465, October 1996.
- Kayano, T., Ochiai, S., Kiyono, K., Yamamoto, H., Nakajima, S. and Mochizuki, T. Effect of Er:YAG laser irradiation on human extracted teeth. *J Clin Laser Med Surg*, 4: 147-150, 1991.
- Keller, U. and Hibst, R.: Effects of Er:YAG laser in caries treatment: A clinical pilot study. *Lasers Surg Med*, 20 (1): 32-38, 1997.
- Keller, U. and Hibst, R.: Experimental studies of the application of the Er:YAG laser on dental hard substances: . Light microscopic and SEM investigations. *Lasers Surg Med*, 9 (4):345-351, 1989.
- Keller, U., Hibst, R., Geurtsen, W., Schilke, R., Heidemann, D., Klaiber, B. and Raab, W. H.: Erbium:YAG laser application in caries therapy. Evaluation of patient perception and acceptance. *J Dent*, 26 (8): 649-656, November 1998.
- Komori, T., Tokoyama, K., Matsumoto, Y. and Matsumoto, K.: Erbium:YAG and holmium:YAG laser root resection of extracted human teeth. *J Clin Laser Med Surg* 15 (1): 9-13, 1997.
- Koukichi, M. Yukio, N., Kazuko, M. and Yuichi, K.: Clinical dental application of Er:YAG laser for Class cavity preparation. *J Clin Laser Med and Surg*, 14: 123-127, 1996.
- Li, Z. Z., Code, J. E. and Van De Merwe, W. P.: Er:YAG laser ablation of enamel and dentin of human teeth: determination of ablation rates at various fluences and pulse repetition rates. *Lasers Surg Med*, 12 (6): 625-630, 1992.
- Matsumoto, K., Nakamura, Y., Mazeki, K. and Kimura, Y.: Clinical dental application of Er:YAG laser for Class cavity preparation. *J Am Dent Assoc*, 123-127, 1996.
- Miserendino, L. J., Abt, E., Wigdor, H. and Miserendino, C. A.: Evaluation of thermal cooling mechanisms for laser application to teeth. *Lasers Surg Med*, 13 (1): 83-88, 1993.
- Morioka, T., Tagomori, S. and Oho, T.: Acid resistance of lased human enamel with Erbium:YAG laser. *J Clin Laser Med Surg*, 13(1):23-26, 1994.

- Moritz, M., Niederdellmann, H. and deuerling, C., et al.: In vitro light and scanning electron microscopic study involving Erbium:YAG laser irradiation of temporomandibular joint tissue. *J Clin Laser Med Surg*, 13 (1): 23 - 26, 1994.
- Neev, J., Pham, K., Lee, J. and White, J.: Dentin ablation with three infrared lasers. *Lasers Surg Med*, 18: 121-128, 1996.
- Nelson, D. G. A., Wefel, J. S., Jongbloed, W. L. and Featherstone, J. D. B.: Morphology, histology and crystallography of human dental enamel treated with pulsed low energy infrared laser radiation. *Caries Res*, 21: 411-426.
- Paghdiwala, A. F.: Root resection of endodontically treated teeth by Er:YAG laser radiation. *J Endodontics*, 19 (2): 91-94, 1993.
- Pelagalli, J., Gimbel, C. G., Hansen, R. T., Swett, A. and Winn, D.: Investigational study of the use of the Er:YAG laser versus dental drill for caries removal in cavity preparation - phase. *J Clin Laser Med Surg*, 15 (3): 109-115, 1997
- Rechmann, P., Goldin, D. S. and Henning, T.: Er:YAG lasers in dentistry: An overview. *SPIE*, 3248:2-13, 1998.
- Srebro, L., Segal, T., Nordenberg, D., Gorfil, C. and Bar-Lev, M.: Examination of tooth pulp following laser beam irradiation. *Lasers Surg Med*, 7: 236-239, 1987.
- Visuri, S. R., Gilbert, J. L., Wright, D. D., Wigdor, H. A. and Walsh, J. T., Jr.: Shear strength of composite bonded to Er:YAG laser-prepared dentin. *J Dent Res* 75 (1): 599-605, 1996.
- Visuri, S. R., Walsh, J. T., Jr. and Wigdor, H. A.: Erbium laser ablation of dental hard tissue: Effect of water cooling. *Lasers Surg Med*, 18 (3): 294-300, 1996.
- Walsh, J. T., Flotte, T. J. and Deutsch, T. F.: Er:YAG laser ablation of tissue: Effect of pulse deviation and tissue type on thermal damage. *Lasers Surg Med*, 9: 314-326, 1989.
- Wigdor, H.: Patients' perception of lasers in dentistry. *Lasers Surg Med*, 20:47-50, 1997.

8. Troubleshooting

Explanation of Error and Caution Messages

If an error message is appeared in the LCD touch screen, follow the message and instruction table below.

Contact your local dealer or J. MORITA OFFICE in the following cases:

- Repairs are required
- Replacement of parts such as the flash lamp, cooling water, deionization filter cartridge etc.
- Calibrating laser output (updating the V-J table)
- Cleaning the internal filter
- Frequent or repeated errors

A message appears in the LCD touch screen when a following error occurs.

No.	Type	Explanation and Response	Reference
Interlock 1	Flash lamp defect.	Lamp is defective or doesn't light up. Response: Flash lamp is old and not working properly. Go to Menu and use Refresh Lamp. If this does not work, contact your local dealer or J. MORITA OFFICE.	
Interlock 2	Main power supply is abnormal.	Cannot charge Up. Response: Restart the unit. If this does not work, contact your local dealer or J. MORITA OFFICE.	
Interlock 4	Coolant Problem	Cooling water is not circulating. Response: Either the pump is not working or there is no cooling water in the unit. Turn the power off, wait about 10 seconds, and then turn the power on again. Open the front cover and see if there is enough cooling water.	
Interlock 5	Shutter error	Shutter is not working properly. Response: Restart the unit. If this does not work, contact your local dealer or J. MORITA OFFICE.	
Interlock A	Hollow waveguide is not connected.	The hollow waveguide is not connected. Response: The hollow waveguide may be loose. Tighten the connection ring and restart the unit. If this does not work, contact your local dealer or J. MORITA OFFICE.	
Interlock B	Not enough cooling water.	Not enough cooling water. Contact your local dealer or J. MORITA OFFICE.	
Interlock C	Cooling water is too hot	Cooling water is too hot, over +45°C (+113°F). Response: Wait until the water cools down to below +45°C (+113°F). Check current temperature. This will happen less often if there is plenty of open space in back of the unit.	If this happens frequently, the filter inside the unit may be plugged up. Contact your local dealer or J. MORITA OFFICE to have the filter cleaned.

No.	Type	Explanation and Response	Reference
Interlock D	Coolant too cold	Cooling water is too cold, less than +15°C (+59°F). Wait for it to warm up. Response: Leave the unit on and wait for the water to warm up; it will then automatically start to operate normally. Check current temperature.	This commonly happens in the winter when the room is cold.
Interlock F	Cover Interlock	Cover interlock activated. Response: Restart the unit. If this does not work, contact your local dealer or J. MORITA OFFICE.	
Interlock G	Remote Interlock	Remote interlock activated. Response: Check the door for the remote interlock. Or check the remote interlock connection on the back of the unit.	
100	Emergency Stop Alarm	The emergency stop switch has been pressed. Response: Turn off the main power and release the emergency switch. Then restart the unit.	Push the emergency switch again after it has been activated to release it.
101	Watch Dog Timer	Watch Dog Timer activated. Response: Restart the unit. If this does not work, contact your local dealer or J. MORITA OFFICE.	
102	Switch error	A switch error was detected when the unit was turned on. Response: This happens if the foot switch is depressed when the unit is turned on. Let the foot switch up and restart the unit.	The foot switch is checked for safety when the unit is turned on.
103	Memory Back-up Error (SRAM)	Battery for memory is low. To recharge the back-up battery, turn on the power and leave it on for 30 minutes. Then reset the clock and rewrite the names for the memories.	A rechargeable battery is used to maintain the clock and other functions. Turn the unit on once every 6 months to recharge the battery.
104	Laser output Error	Laser output does not match set value. Response: The flash lamp is probably old and not working right. Go to Menu and use Refresh Lamp. If this does not work, contact your local dealer or J. MORITA OFFICE.	
105	Energy Setting Error	Energy level cannot be properly set. Response: Probably needs calibration. Contact your local dealer or J. MORITA OFFICE.	This happens if the laser has not been calibrated for some time.
106	Voltage limit stop	Cannot produce the output power that has been set. Response: Lower the output power (mJ), or replace the flash lamp. If an error occurs even after the power has been lowered, a mirror may be damaged; in this case, contact J. MORITA OFFICE.	This happens if the flash lamp is in poor condition
110	Temporary power failure	Temporary power failure error. Response: Restart the unit. Check the socket for the main power cord.	Happens when main AC power source is temporarily lost.

No.	Type	Explanation and Response	Reference
113	Memory back-up error (EEPROM)	Memory for EEPROM has been erased. Response: For proper laser output, the characteristic values must be reset. Contact J. MORITA OFFICE.	
201	Pulse misses	Laser is skipping pulses Response: The flash lamp is probably old and not working right. Go to Menu and use Refresh Lamp. If this does not work, contact your local dealer or J. MORITA OFFICE.	
202	Communication error	Communication failure from panel to laser control unit. Response: Restart the unit. If this does not work, contact your local dealer or J. MORITA OFFICE.	
204	Purge air error	Cooling air for the hollow waveguide not detected. Response: The hollow waveguide may be loose. Tighten the connection ring and restart the unit. If this does not work, contact your local dealer or J. MORITA OFFICE. Cable could be damaged if used as is.	
205	Laser output too high	Laser output does not match set value. Response: Restart the unit. If this does not work, contact your local dealer or J. MORITA OFFICE.	This happens if the laser has not been calibrated for some time.
206	Sudden laser output anomaly	Sudden deviation of laser output. Response: Restart the unit. If this does not work, contact your local dealer or J. MORITA OFFICE.	
208	Sudden output drop	Output suddenly dropped. Response: Possible mirror damage. Contact J. MORITA OFFICE.	Detected during start up.
501	Time to replace cooling water and deionization filter cartridge.	Time to replace the cooling water and the deionization filter cartridge. Response: contact your local dealer or J. MORITA OFFICE. The AdvErL EVO could be damaged if the both are not replaced on time. Replace them as soon as possible, within 1 or 2 months.	Replace the cooling water and the deionization filter cartridge once a year.
502	Flash Lamp is worn out.	After 10 million shots the flash lamp should be replaced as its performance will start to deteriorate. After 20 million shots the lamp has reached the end of its working life. Although it can still be used errors will occur more and more frequently; replace it right away. Go to the Menu to check the total shot number for the lamp.	Go to the Menu and check Lamp Shot Number.

Troubleshooting for Problems Other than Error Messages.

If the procedures described below do not solve the problem, please contact your local dealer or J. MORITA OFFICE.

Problem	Cause	Response
The device does not start.	Circuit Protector may be in the off position	Make sure the Circuit protector on the back of the Main unit is not in the off position.
Low laser output or Aiming beam is not emitted or Aiming beam is dim or hazy	Contact tip is damaged.	Wear or damage (such as chipping) will reduce the efficiency of the contact tip, and lower the laser output. When the contact tip wears down to the metal sleeve, the laser output is almost gone. Replace the contact tip.
	Lens of Handpiece (Drum Lens) or lens of R handpiece grip (Ball lens) is dirty or damaged.	Clean the Drum lens or the Ball lens. (See page 46) This will lower the laser output and cause aiming beam trouble. Replace the lens if it is extremely dirty, scratched or otherwise damaged.
	Water leaks inside the handpiece.	Water leaks inside the handpiece if the O-rings on the contact tip or handpiece are damaged. This will lower the laser output and cause aiming beam trouble. Try using another handpiece or a new contact tip. Grease the handpiece grip every day before use or after putting it on and taking it off more than 50 times. (See page 45)
	Poor assembly of hollow waveguide.	Make sure the hollow waveguide is neatly parallel to the hollow waveguide support.
	Hollow waveguide is broken	Replace the Hollow waveguide. Contact your local dealer or J. MORITA OFFICE.
Spray water is not emitted from the contact tip.	Spray water bottle is empty.	Replace the spray water bottle.
	Air got in the tube when replacing the spray water bottle.	When the bottle is replaced or the device is not used for a long time, some air will get in the water tube. Set the device in Ready mode and depress the foot switch to its first level to run the spray water pump until water is coming out.
	The water flow path of the contact tip is plugged up.	Replace the contact tip and make sure the spray water is coming out.
	Spray water connector is not properly plugged in.	Reconnect the connector. (See page 50)

Problem	Cause	Response
Spray air is not emitted from the contact tip.	Air is leaking inside the handpiece	Air will leak inside the handpiece if the O-rings on the contact tip or handpiece are damaged. Try using another handpiece or a new contact tip. Grease the handpiece grip every day before use or after putting it on and taking it off more than 50 times. (See page 45)
Water collects inside the handpiece	Water is leaking inside the handpiece.	Water will leak inside the handpiece if the O-rings on the contact tip or handpiece are damaged. This will lower the laser output and cause aiming beam trouble. Try using another handpiece or a new contact tip. Grease the handpiece grip every day before use or after putting it on and taking it off more than 50 times. (See page 45)
Water does not stop immediately when the foot switch is released or drips from the end of the contact tip.	There is air in the water tube	Put the device in Ready mode and depress the foot switch to the first level for about 30 seconds to clear the water tube of air.
Log key does not appear on the LCD touch screen	The key is set for Hidden.	This is the factory settings. Go to the Menu to change the setting to Show.
Log key starts blinking.	More than 900 log records have not yet been copied.	The log saves up to 1,000 records. If more than 900 records have not yet been copied onto a USB flash drive, the Log key starts blinking. Copy the log onto a USB flash drive.
Sound of fans is frequently noisy.	Lack of space for air ventilation to cool the device.	Make space on the sides and back of the device for air ventilation.
	Lack of cooling air due to clogged air filter.	Cleaning of air filter is needed. The cooling water not properly cooled if air filter of heat exchanger is clogged with dust, and fans will run high speed. Contact your local dealer or J. MORITA OFFICE.
The cooling water inside the tank is cloudy.	The quality of the cooling water is degraded.	Replacement of the cooling water is needed. If the cooling water is cloudy or degraded, stop using the device and replace the cooling water. Otherwise, the device could malfunction. Contact your local dealer or J. MORITA OFFICE. To keep the quality of the cooling water from degrading, especially when the device is not being used for a long time, turn the power on and circulate the cooling water through the deionization filter cartridge for 15 minutes at least once a month.
LCD touch screen does not respond while log is being copied onto a USB flash drive.	Something is wrong with the USB flash drive.	Remove the USB flash drive.

Problem	Cause	Response
Fluorescent lights in the room flicker when the laser is emitted.	The main power source may not be good enough.	<ul style="list-style-type: none"> • Plug the device into another receptacle. • Plug the fluorescent light into another receptacle. • Use separate circuits for the device and the fluorescent lights. • Replace the lights with inverter type fluorescent lights.

Example of circuit that can cause fluorescent lights to flicker.
 Rather low (20 amps) breaker current capacity can cause lights to flicker.

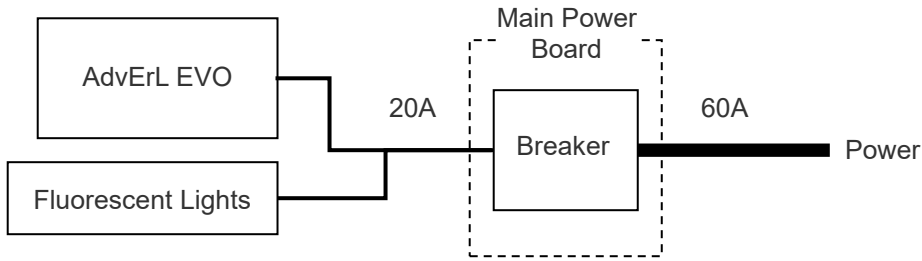

Example of circuit that is not likely to cause fluorescent lights to flicker.
 Use separate breakers for this device and the fluorescent lights.

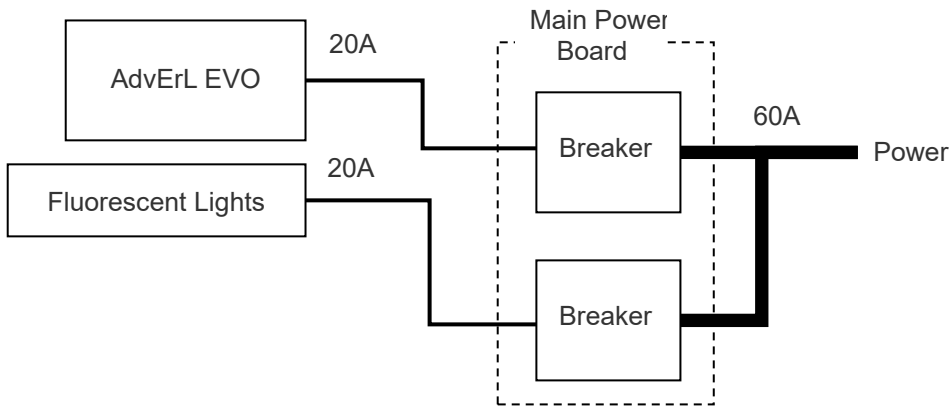

9. Technical Description

Name	AdvErL EVO
Model	MEY-1-A
Type	EX-1
Rating	AC 100 V to 240 V \pm 10%
Frequency	50/60 Hz
Power Consumption	1.5 kVA
Electric Shock Protection Class	Class I
Electric Shock Protection Type	Type B with applied component
Laser Classification	Class 4 < Er:YAG Laser >
Laser Stimulation Method	Pulsed Stimulation
Laser Medium	Er:YAG
Laser Energy	30 mJ to 400 mJ per pulse (at handpiece tip) For a pulse rate higher than 10 pps: 20 pps: 30 mJ/pulse to 170 mJ/pulse 25 pps: 30 mJ/pulse to 80 mJ/pulse
Pulse Rate	1, 3.3, 5, 10, 20, 25 pps
Wavelength	2.94 μ m
Beam Spread Angle	\geq 8° (full width at handpiece tip)
Nominal Ocular Hazard Distance	41 cm from handpiece tip
Aiming beam	Wavelength 650 nm
Transmission Method	Hollow Waveguide System
Outer dimensions	(Width) 246 mm \times (Depth) 469 mm \times (Height) 732 mm
Weight	Approx. 49 kg
Degree of Protection against Ingress of Water	IPX8 (Foot Switch)
Operation Environments	
Temperature	+10°C to +35°C (+50°F to +95°F)
Humidity	30% to 75% (without condensation)
Atmospheric Pressure	70 kPa to 106 kPa
Storage Environments	
Temperature	+5°C to +40°C (+41°F to +104°F)
Humidity	10% to 85% (without condensation)
Atmospheric Pressure	70 kPa to 106 kPa
Transport Environments (without cooling water and spray water)	
Temperature	-10°C to +70°C (+14°F to +158°F)
Humidity	10% to 85% (without condensation)
Atmospheric Pressure	70 kPa to 106 kPa

* Specifications may be changed without notice due to improvements.

■ Disposal of Medical Devices

Any medical devices which could possibly be contaminated must be first decontaminated by the responsible doctor or medical institution and then be disposed by an agent licensed and qualified to handle medical and industrial waste.

The package should be recycled. Metal parts of the device are disposed as scrap metal. Synthetic materials, electrical components, and printed circuit boards are disposed as electrical scrap. Material must be disposed according to the relevant national legal regulations. Consult specialized disposal companies for this purpose. Please inquire of the local city/community administrations concerning local disposal companies.

■ Service

AdvErL EVO may be repaired and serviced by:

- The technicians of J. MORITA's subsidiaries all over the world.
- Technicians employed by authorized J. MORITA dealers and specially trained by J. MORITA.
- Independent technicians specially trained and authorized by J. MORITA.

10. Electromagnetic Compatibility (EMC)

This device conforms to IEC 60601-1-2:2007 Ed.3.0, the relevant international standard for electromagnetic compatibility (EMC).

The following is the “Guidance and Manufacturer’s Declaration” which is required by IEC 60601-1-2:2007 Ed. 3.0, the relevant international standard for electromagnetic compatibility.

WARNING

- *The AdvErL EVO (hereafter referred to as the MEY-1-A) needs special precautions regarding EMC and needs to be installed and put into service according to the EMC information provided in the ACCOMPANYING DOCUMENTS.*
- *Portable and mobile RF communications equipment can affect the MEY-1-A.*
- *Use of parts other than those accompanied or specified by J.MORITA MFG.CORP. may result in increased EMC emissions or decreased EMC immunity of the MEY-1-A.*
- *The MEY-1-A should not be used adjacent to with other equipment and that if adjacent use is necessary, the MEY-1-A should be observed to verify normal operation in the configuration in which it will be used.*

Guidance and Manufacturer’s Declaration – Electromagnetic Emissions

The MEY-1-A is intended for use in the electromagnetic environment specified below. The customer or the user of the MEY-1-A should assure that it is used in such an environment.

Emissions Test	Compliance	Electromagnetic Environment – Guidance
RF Emission CISPR 11	Group 1	The MEY-1-A uses RF energy only for internal function. Therefore, its RF emissions are very low and are not likely to cause any interference in nearby electronic equipment.
RF Emission CISPR 11	Class B	The MEY-1-A is suitable for use in all establishments, including domestic establishments and those directly connected to the public low-voltage power supply network that supplies buildings used for domestic purposes.
Harmonic emissions IEC61000-3-2	Class A	
Voltage fluctuations / flicker emissions IEC 61000-3-3	Complies	

Guidance and Manufacturer's Declaration – **Electromagnetic Immunity**

The MEY-1-A is intended for use in the electromagnetic environment specified below.
The customer or the user of the MEY-1-A should assure that it is used in such an environment.

Immunity Test	IEC 60601 Test Level	Compliance Level	Electromagnetic Environment – Guidance
Electrostatic discharge (ESD) IEC 61000-4-2	±6 kV contact ±8 kV air	±6 kV contact ±8 kV air	Floors should be wood, concrete or ceramic tile. If floors are covered with synthetic material, the relative humidity should be at least 30%.
Electrical fast transient / burst IEC 61000-4-4	±2 kV for power supply lines ±1 kV for input / output lines	±2 kV for power supply lines ±1 kV for input / output lines	Mains power quality should be that of a typical commercial or hospital environment.
Surge IEC 61000-4-5	±1 kV line(s) to line(s) ±2 kV line(s) to earth	±1 kV line(s) to line(s) ±2 kV line(s) to earth	Mains power quality should be that of a typical commercial or hospital environment.
Voltage dips, short interruptions and voltage variations on power supply input lines IEC 61000-4-11	<5 % U_T (>95 % dip in U_T) for 0.5 cycle 40 % U_T (60 % dip in U_T) for 5 cycles 70 % U_T (30 % dip in U_T) for 25 cycles <5 % U_T (>95 % dip in U_T) for 5 sec.	<5 % U_T (>95 % dip in U_T) for 0.5 cycle 40 % U_T (60 % dip in U_T) for 5 cycles 70 % U_T (30 % dip in U_T) for 25 cycles <5 % U_T (>95 % dip in U_T) for 5 sec.	Mains power quality should be that of a typical commercial or hospital environment. If the user of the MEY-1-A requires continued operation during power mains interruptions, it is recommended that the MEY-1-A be powered from an uninterruptible power supply or a battery.
Power Frequency (50 / 60 Hz) magnetic field IEC 61000-4-8	3 A/m	3 A/m	Power frequency magnetic fields should be at levels characteristic of a typical location in a typical commercial or hospital environment.

Note: U_T is the a.c. mains voltage prior to application of the test level.

Guidance and Manufacturer's Declaration – **Electromagnetic Immunity**

The MEY-1-A is intended for use in the electromagnetic environment specified below.
The customer or the user of the MEY-1-A should assure that it is used in such an environment.

Immunity Test	IEC 60601 Test Level	Compliance Level	Electromagnetic Environment – Guidance
<p>Conducted RF IEC 61000-4-6</p> <p>Radiated RF IEC 61000-4-3</p>	<p>3 Vrms 150 kHz to 80 MHz</p> <p>3 V/m 80 MHz to 2.5 GHz</p>	<p>3 Vrms</p> <p>3 V/m</p>	<p>Portable and mobile RF communications equipment should be used no closer to any part of the MEY-1-A, including cables, than the recommended separation distance calculated from the equation applicable to the frequency of the transmitter.</p> <p>Recommended separation distances $d = 1.2 \sqrt{P}$ $d = 1.2 \sqrt{P}$ 80 MHz to 800 MHz $d = 2.3 \sqrt{P}$ 800 MHz to 2.5 GHz</p> <p>where P is the maximum output power rating of the transmitter in watts (W) according to the transmitter manufacturer and d is the recommended separation distance in meters (m).</p> <p>Field strengths from fixed RF transmitters, as determined by an electromagnetic site survey,^a should be less than the compliance level in each frequency range.^b</p> <p>Interference may occur in the vicinity of equipment marked with the following symbol:</p> 

Note 1 At 80 MHz and 800 MHz, the higher frequency range applies.

Note 2 These guidelines may not apply in all situations. Electromagnetic propagation is affected by absorption and reflection from structures, objects and people.

a Field strengths from fixed transmitters, such as base stations for radio (cellular/cordless) telephones and land mobile radios, amateur radio, AM and FM radio broadcast and TV broadcast cannot be predicted theoretically with accuracy. To assess the electromagnetic environment due to fixed RF transmitters, an electromagnetic site survey should be considered. If the measured field strength in the location in which the MEY-1-A is used exceeds the applicable RF compliance level above, the MEY-1-A should be observed to verify normal operation. If abnormal performance is observed, additional measures may be necessary, such as reorienting or relocating the MEY-1-A.

b Over the frequency range 150 kHz to 80 MHz, field strengths should be less than 3 V/m.

Recommended Separation Distances between Portable and Mobile RF Communications Equipment and the MEY-1-A

The MEY-1-A is intended for use in an electromagnetic environment in which radiated RF disturbances are controlled.

The customer or the user of the MEY-1-A can help prevent electromagnetic interference by maintaining a minimum distance between portable and mobile RF communications equipment (transmitters) and the MEY-1-A as recommended below, according to the maximum output power of the communications equipment.

Rated Maximum Output Power of Transmitter W	Separation Distance according to Frequency of Transmitter m		
	150 kHz to 80 MHz $d = 1.2\sqrt{P}$	80 MHz to 800 MHz $d = 1.2\sqrt{P}$	800 MHz to 2.5 GHz $d = 2.3\sqrt{P}$
0.01	0.12	0.12	0.23
0.1	0.38	0.38	0.73
1	1.2	1.2	2.3
10	3.8	3.8	7.3
100	12	12	23

For transmitters rated at a maximum output power not listed above, the recommended separation distance d in meters (m) can be estimated using the equation applicable to the frequency of the transmitter, where P is the maximum output power rating of the transmitter in watts (W) according to the transmitter manufacturer.

Note 1 At 80 MHz and 800 MHz, the separation distance for the higher frequency range applies.

Note 2 These guidelines may not apply in all situations. Electromagnetic propagation is affected by absorption and reflection from structures, objects and people.

Essential performance

- : Laser output power fluctuation shall be within $\pm 20\%$ of initial preset power.
- : No operability/controllability loss, no preset data loss, no change of operation mode.

Cable List

Cable Name	Maximum Cable Length	Manufacturer	Shield
AC cord	3 meters	J. MORITA MFG CORP.	No
Foot switch	0.8 meters	J. MORITA MFG CORP.	Yes
Remote interlock cable	5 meters	—	Yes

Ver. 1.04

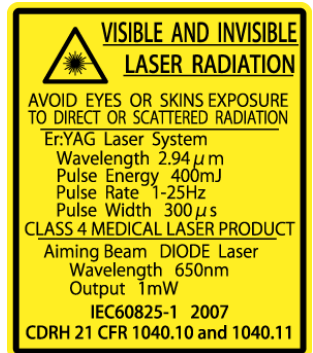
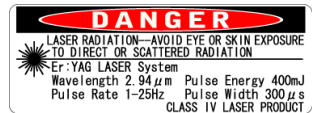

Development and Manufacturing

J. MORITA MFG. CORP.

680 Higashihama Minami-cho, Fushimi-ku, Kyoto 612-8533, Japan T +81. (0)75. 611 2141, F +81. (0)75. 622 4595

Morita Global Website www.morita.com

Distribution

J. MORITA CORP.

3-33-18 Tarumi-cho, Suita-shi, Osaka 564-8650, Japan
T +81. (0)6. 6380 1521, F +81. (0)6. 6380 0585

J. MORITA USA, INC.

9 Mason, Irvine CA 92618, USA
T +1. 949. 581 9600, F +1. 949. 581 8811

J. MORITA EUROPE GMBH

Justus-von-Liebig-Strasse 27b, 63128 Dietzenbach, Germany
T +49. (0)6074. 836 0, F +49. (0)6074. 836 299

MORITA DENTAL ASIA PTE. LTD.

150 Kampong Ampat #06-01A KA Centre, Singapore 368324
T +65. 6779. 4795, F +65. 6777. 2279

J. MORITA CORP. AUSTRALIA & NEW ZEALAND

Suite 2.05, 247 Coward Street, Mascot NSW 2020, Australia
T +61. (0)2. 9667 3555, F +61. (0)2. 9667 3577

J. MORITA CORP. MIDDLE EAST

4 Tag Al Roasaa, Apartment 902, Saba Pacha 21311 Alexandria, Egypt
T +20. (0)3. 58 222 94, F +20. (0)3. 58 222 96

J. MORITA CORP. INDIA

Filix Office No.908, L.B.S. Marg, Opp. Asian Paints,
Bhandup (West), Mumbai 400078, India
T +91-82-8666-7482

J. MORITA MFG. CORP. INDONESIA

28F, DBS Bank Tower, Jl. Prof. Dr. Satrio Kav. 3-5, Jakarta 12940, Indonesia
T +62-21-2988-8332, F + 62-21-2988-8201

SIAMDENT CO., LTD.

71/10 Moo 5 T. Tharkham A. Bangpakong Chachuengsao 24130 Thailand
T +66 (0) 3857 3042, F +66 (0) 3857 3043 www.siamdent.com